

STANDARD SPECIFICATIONS

FOR

WATER SYSTEM CONSTRUCTION



JUNE 2022

STANDARD SPECIFICATIONS

FOR

WATER SYSTEM CONSTRUCTION

DW20220779

APPROVED WATER SPECIFICATIONS

THE DOCUMENT BEARING THIS STAMP HAS BEEN RECEIVED AND REVIEWED BY THE

TENNESSEE DEPT. OF ENVIRONMENT & CONSERVATION

DIVISION OF WATER RESOURCES

AND IS HEREBY APPROVED FOR USE IN CONSTRUCTION BY THE COMMISSIONER



07/25/2022

THIS APPROVAL SHALL NOT BE CONSTRUED AS CREATING A PRESUMPTION OF CORRECT OPERATION OR AS WARRANTING BY THE COMMISSIONER THAT THE APPROVED FACILITIES WILL REACH THE DESIGNED GOALS.

APPROVAL EXPIRES FIVE YEARS FROM ABOVE DATE



KNOX CHAPMAN UTILITY DISTRICT

PREFACE

The Standard Specifications have been prepared to complement the Standard Detail Drawings and to provide the qualitative requirements for products, materials, and workmanship for construction of additions to and replacements of the water distribution system which is to be operated by Knox Chapman Utility District (KCUD). These Standard Specifications are only to be used for projects with Drawings which have been approved by the Tennessee Department of Environment and Conservation, Division of Water Supply, as prepared by KCUD, by its design consultant, or by a developer's engineer, whose Drawings must first be approved by KCUD. All references in these Standard Specifications to "Engineer" and "Owner" shall mean the Knox Chapman Utility District. These Standard Specifications are subject to revision for a specific project, with such revisions identified in the Bidding Requirements and Special Conditions document prepared by KCUD or its design consultant, or with such revisions noted on the Drawings approved by KCUD.

All work requirements described in the Standard Specifications are the responsibility of the Contractor, unless specifically designated otherwise.

SPECIFICATIONS

SECTION TITLE

Division 01 – General Requirements

01 14 00	General Provisions
01 32 33	Construction Videos and Photographs
01 33 23	Shop Drawings, Product Data, and Samples
01 45 29	Testing Laboratory Services
01 50 00	Temporary Construction Facilities and Controls
01 56 33	Jobsite Security
01 57 13	Erosion and Sedimentation Control
01 77 19	Contract Close-Out
01 78 23	Operating and Maintenance Data
01 78 36	Warranties and Bonds
01 78 39	Record Documents

Division 31 – Earthwork

31 11 00	Clearing and Grubbing
31 23 33	Trench Excavation and Backfill

Division 32 – Exterior Improvements

32 10 13	Removing and Replacing Pavement
32 92 19	Permanent Seeding

Division 33 – Utilities

33 05 23.16	Bore and Jack Casings
33 10 00	Water Mains and Accessories
33 12 13	Water Service Connections

STANDARD DETAIL DRAWINGS

<u>SHEET</u>	<u>TITLE</u>
STD-G-01	Silt Fence Detail
STD-G-02	Concrete Encasement Detail
STD-G-03	Concrete Replacement Detail
STD-G-04	Asphalt Replacement Detail
STD-G-05	Stream Crossing Detail
STD-G-06	Road Bore Detail
STD-G-07	Trench Terminology Detail
STD-G-08	Pressure Pipe Bedding and Haunching Details
STD-W-01	Typical Blocking Detail
STD-W-02	Gate Valve Installation Detail
STD-W-03	Butterfly Valve Installation Detail
STD-W-04	Fire Hydrant Assembly Detail
STD-W-05	Typical Automatic Air Release Valve Assembly Detail
STD-W-06	Water Main Blow-Off Detail Large Dia. Mains
STD-W-07	Water Service and Meter Connection Details
STD-W-08	Double Tap Assemblies Detail
STD-W-09	Water Main Termination Detail

PART 1 GENERAL

1.1 DESIGNATION OF PARTIES

- A. All references in the Specifications, Contract Documents, and Drawings to “Owner” shall mean Knox Chapman Utility District and all references to “Engineer” shall mean W.K. Dickson & Co., Inc.

1.2 MINIMUM REQUIREMENTS

- A. These Specifications are only the minimum requirements; actual requirements may be greater depending upon the situation. These Specifications may be adjusted by the sole discretion of the Owner to fit a particular situation not routinely encountered, or as public safety issues become apparent.

1.3 ACCESS TO INSPECTION OF WORK

- A. Representatives of the Tennessee Department of Environment and Conservation (TDEC), Tennessee Department of Transportation (TDOT), County Public Works, and local public health agencies, Owner, and Engineer shall at all times have full access to the project site for inspection of the work accomplished under this Contract and for inspection of all materials intended for use under the Contract. The Contractor shall provide proper facilities for such access and inspection.

1.4 CONSTRUCTION SCHEDULE CHART

- A. Prior to start of any construction, the Contractor shall furnish a construction schedule or progress chart. The schedule or chart shall be subject to the approval of the Engineer and be of sufficient detail to show the chronological relationship of all activities of the project, the order in which the Contractor proposes to carry on the work, estimated starting and completion dates of major features, procurement of materials, and scheduling of equipment. The schedule shall be in a form suitable for appropriately indicating the percentage of work scheduled for completion at any time. The schedule shall be kept current and shall reflect completion of all work under the Contract within the specified time and in accordance with these Specifications.

1.5 PRE-CONSTRUCTION CONFERENCE

- A. The Contractor, Engineer, and Owner, or their duly appointed representative, shall meet in a Pre-Construction Conference prior to the initiation of construction to organize, schedule, and determine responsibilities for the work as it pertains to each party of the Contract.

1.6 TAXES

- A. Proposals shall be made to include any applicable taxes on payrolls, materials, equipment, vehicles, utilities, etc., including state sales taxes and shall include compensation for such taxes on all work under this Contract.

1.7 LINES AND GRADES

- A. The Engineer has shown on the plans, available information in sufficient detail to enable the Contractor to proceed with the work. The Contractor shall be responsible for all lines and grades required for the construction of piping.
- B. The Contractor shall furnish all materials, stakes, and grade boards required for layout by the Contractor's forces. In addition, the Contractor shall furnish any necessary survey personnel to mark the location of the various facilities on the ground, establishing bench levels, and determining as-built conditions after work is completed. The Contractor's personnel engaged in the layout work described herein and the aides furnished to the Engineer shall be fully capable of performing the duties set out herein and shall be fully qualified as required. Contractor shall be responsible for verifying all profiles and elevations prior to construction.
- C. All survey work shall be performed under the direct supervision of a surveyor licensed in the State of Tennessee.

1.8 BLASTING

- A. Blasting is prohibited unless conditionally approved by the Owner and the Highway authority. Contractor will comply with all applicable seismic criteria and furnish photography of before and after blasting operations. Contractor assumes all liability for his blasting activities.
- B. Definition of Rock: Any material which cannot be excavated with conventional excavating equipment, and is removed by drilling and blasting, and occupies an original volume of at least one-half cubic yard.
- C. Removal of Rock: Dispose of rock off-site that is surplus or not suitable for use as rip rap or backfill.
- D. The Contractor shall notify the Engineer prior to any blasting. Additionally, the Contractor shall notify the Engineer before any charge is set.
- E. Following review by the Engineer regarding the proximity of permanent buildings and structures to the blasting site, the Engineer may direct the Contractor to employ an independent, qualified specialty subcontractor, approved by the Engineer, to monitor the blasting by use of seismograph, identify the areas where light charges must be used, conduct pre-blast and post-blast inspections of structures, including photographs or videos, and maintain a detailed written log.

1.9 COMPLIANCE WITH SAFETY REGULATIONS

- A. The equipment items furnished shall comply with all governing federal and state laws regarding safety, including all current requirements of the Occupational Safety and Health Act (OSHA). Contractor shall be solely responsible for job safety in accordance with all laws, regulations, methods, etc., of OSHA and the State of Tennessee.
- B. All work under this Contract shall be done in strict compliance with the OSHA of 1970 (PL 91-596) and under Section 107 of the Contract Work Hours and Safety Standards Act (PL91-54).

- C. It is not the intention of these Specifications to conflict with OSHA in any way, and where conflicts may arise, OSHA shall govern.

1.10 OBSTRUCTIONS

- A. In cases where storm sewers, sanitary sewers, gas lines, water lines, telephone lines, electric lines or other overhead and underground structures are encountered, they shall not be displaced or molested unless necessary, in which case they shall be replaced in as good a condition as found and as quickly as possible.
- B. The Contractor is responsible for notifying the appropriate utility companies and coordinating the protection of the utility. All such lines or underground structures damaged or molested in the construction shall be replaced at the Contractor's expense, unless in the opinion of the Engineer, such damage was caused through no fault of the Contractor.
- C. With particular respect to existing underground utilities, all available information concerning their location has been shown on the plans. While it is believed that the locations shown are reasonably correct, neither the Engineer nor the Owner can guarantee the accuracy or adequacy of this information.
- D. It is suggested the Contractor locate all unknown metallic hazards, namely buried pipe, metals, etc., by using a pipe locator. The pipe locator should immediately precede the trench ditching and all hazards located and marked with a pointed stake in such manner as to notify the ditcher operator of such hazard. The Engineer may require this procedure.
- E. It is expected the Contractor will be diligent in his/her efforts and use every possible means to locate existing utilities. Any claims for unavoidable damage, based on improper or unknown locations, will be thoroughly examined in light of the Contractor's efforts to locate the said utilities or obstructions prior to beginning construction.

1.11 STORAGE FACILITIES

- A. The Contractor shall be responsible for proper and adequate storage of all materials and equipment used on the site. Any additional off-site space required for construction purposes shall be the Contractor's responsibility to obtain.
- B. Upon completion of the work, the Contractor shall remove all storage facilities, surplus materials, and equipment, and restore the site to its original condition, or to the finished condition as required by the Contract.

1.12 STANDARDS OF WORKMANSHIP

- A. Work of all crafts and trades shall be laid out to lines and elevations as established by the Contractor from the Drawings or from instructions by the Engineer. Unless otherwise shown, all work shall be plumb and level, in straight lines and true planes, parallel or square to the established lines and levels. The work shall be accurately measured and fitted to tolerance as established by the best practices of the crafts and trades involved and shall be as required to fit all parts of the work carefully and neatly together.

1.13 PERFORMANCE AND PAYMENT BONDS

- A. Performance and Payment Bonds, as specified in Document 00 72 15, General Conditions, of these Specifications, shall run for a period of 1 year after final acceptance of the work by the Owner. These bonds shall be executed on the forms provided as a part of the Contract Documents.

1.14 WARRANTY

- A. Except as otherwise specified herein, the Contractor shall guarantee all work from latent defects in materials, equipment, and workmanship for 1 year from the date of final completion of the Contract. The date of final completion shall be the date upon which the final estimate is approved by the Owner or the date of substantial completion. In case any date but the date of final completion is established to govern the time of the warranty, such date shall be duly recorded together with the terms and conditions of such agreement.
- B. The Contractor agrees he will obtain from the Manufacturers of equipment and materials furnished under this Contract, guarantees against defective materials and workmanship, and if those guarantees furnished by the Manufacturer do not extend for the term of 1 year from and after the date upon which the final estimate is formally approved by the Owner or other established date as set forth hereinbefore, he shall make the necessary arrangements and assume all cost for extending this guarantee for the required period.
- C. The Contractor shall promptly make such repairs or replacement as may be required under the above specified guarantee; and, when the repairs or replacements involve one or more items of installed equipment, shall provide the services of qualified factory-trained servicemen in the employ of the Equipment Manufacturer to perform or supervise the repairs or replacements.
- D. When the Engineer or the Owner deems it necessary, and so orders, such replacements or repairs under this section shall be undertaken by the Contractor within 24 hours after service of notice. If the Contractor unnecessarily delays or fails to make the ordered replacements or repairs within the time specified, or if any replacements or repairs are of such nature as not to admit of the delay incident to the service of a notice, then the Owner shall have the right to make such replacements or repairs, and the expense thereof shall be paid by the Contractor or deducted from any moneys due the Contractor.
- E. The Performance Bond shall remain in full force and effect throughout the Guaranty period.
- F. All warranties and guarantees remaining in effect at and beyond the warranty expiration date shall be relinquished and transferred to the Owner. Copies of such warranty/guaranty shall be submitted to the Engineer prior to date of the start of the warranty period.

1.15 TRAFFIC CONTROL AND MAINTENANCE

- A. Traffic shall be maintained on all highways and streets at all times during construction of pipelines across or alongside said highways and streets. Access to all existing subdivisions and private residences shall also be kept open. Work shall be performed in accordance with applicable City of Knoxville, Knox County, and TDOT guidelines. Traffic control shall include proper signing and flagging per these guidelines.

- B. Traffic shall be maintained in accordance with the Manual on Uniform Traffic Control Devices. Work shall include all labor and materials necessary for construction and maintenance of traffic control devices and markings.
- C. Traffic control shall also include all flag persons and traffic control devices such as, but not limited to, flashers, signs, barricades and vertical panels, plastic drums (steel drums will not be permitted) and cones necessary for the control and protection of vehicular and pedestrian traffic as specified by the Manual on Uniform Traffic Control Devices.
- D. Any temporary traffic control items, devices, materials, and incidentals shall remain the property of the Contractor when no longer needed.
- E. The Contractor shall maintain a 2-lane traveled way with a minimum lane width of 10 feet; however, during working hours, 1-way traffic may be allowed at the discretion of the Engineer, provided adequate signing and flag persons are at the location.
- F. The Contractor shall fully cover with plywood any signs, either existing, permanent or temporary, which do not properly apply to the current traffic phasing and shall maintain the covering until the signs are applicable or are removed.
- G. In general, all traffic control devices shall be placed starting and proceeding in the direction of the flow of traffic and removed starting and proceeding in the direction opposite to the flow of traffic.
- H. The Engineer and Contractor shall review the signing before traffic is allowed to use lane closures, crossovers or detours, and all signing shall be approved by the Engineer before work can be started by the Contractor.
- I. If traffic should be stopped due to construction operations and an emergency vehicle on an official emergency run arrives on the scene, the Contractor shall make provisions for the passage of that vehicle immediately.

1.16 CONSTRUCTION ALONG OR ACROSS A STREAM

- A. All excavations along or across a stream shall be done in such a manner as to prevent degradation of the waters. Spoil material shall not be allowed to enter the flowing portion of the stream.
- B. Effective erosion and sedimentation measures must be employed at all times during the project to prevent degradation of the waters.
- C. Site regrading and reseeding shall be accomplished within 14 days after disturbance, regardless of the season.

1.17 EXECUTION AND COORDINATION OF THE WORK

- A. General:
 - 1. It is intended the work covered by this Contract be done so as to cause the minimum interference with the normal operation of the existing water distribution system. The Contractor will be required to organize and schedule his/her work so

as to keep the existing facilities in full operation during the construction period insofar as is consistent with the nature of the construction work to be performed.

2. The manner in which shutdowns will be made, and the Contractor's work schedule will be subject to the approval of the Owner and the Engineer; and although every effort will be made to cause the minimum amount of interference with the Contractor's work, the interest of the Owner in regard to the existing facilities must always take precedence over the construction work. Therefore, the right is reserved by the Owner to put any lines that may be shut down for the construction work back into service when an emergency arises.
3. The Contractor must have sufficient materials, equipment, labor, and supervision available to accomplish the work required in the time allocated for any shutdown.

1.18 ORDER OF WORK, TIME OF COMPLETION, AND LIQUIDATED DAMAGES

- A. Work on the Contract shall be prosecuted in a timely manner. The work shall be constructed in such a manner portions of the system can be placed into service as soon as possible. Time of completion of the construction Contract shall be as described in the Agreement.
- B. If the work is not completed within the time specified, liquidated damages as described in the Agreement will be deducted from the compensation otherwise due the Contractor.

1.19 WEATHER DELAYS

- A. Extensions of Contract Time: If the basis exists for an extension of time, an extension of time on the basis of weather may be granted only for the number of Weather Delay Days in excess of the number of days listed as the Standard Baseline for that month.
- B. Standard Baseline for Average Climatic Range:
 1. Standard Baseline shall be regarded as the normal and anticipatable number of calendar days for each month during which construction activity shall be expected to be prevented and suspended by cause of adverse weather. Suspension of construction activity for the number of days each month as listed in the Standard Baseline is included in the work and is not eligible for extension of Contract Time.
 2. Standard Baseline of average climatic range for the State of Tennessee as determined from the National Oceanic and Atmosphere Administration (NOAA) is as follows:

Jan	Feb	Mar	Apr	May	Jun	Jul	Aug	Sep	Oct	Nov	Dec
12	11	08	07	07	06	07	05	04	05	06	11

- C. Adverse Weather and Weather Delay Days:
 1. Adverse weather is defined as the occurrence of one or more of the following conditions which prevents exterior construction activity or access to the site within 24 hours:
 - a. Precipitation (rain, snow or ice) in excess of 1/10-inch liquid measure.
 - b. Temperatures which do not rise above 32° F by 10:00 a.m.
 - c. Temperatures which do not rise above that specified for the day's construction activity by 10:00 a.m., if any is specified.
 - d. Sustained wind in excess of 25 m.p.h.
 - e. Standing snow in excess of 1 inch.
 2. Adverse weather may include, if appropriate, "dry-out" or "mud" days:
 - a. For rain days above the Standard Baseline;

- b. Only if there is a hindrance to site access or sitework, such as excavation, backfill, and footings; and
 - c. At a rate not greater than one make-up day for each day or consecutive days of rain beyond the Standard Baseline that totals 1-inch or more, liquid measure, unless specifically recommended otherwise by the Engineer.
3. A Weather Delay Day may be counted if adverse weather prevents work on the project for 50 percent or more of the Contractor's scheduled workday, including a weekend day or holiday, if Contractor has scheduled construction activity that day.

D. Documentation and Submittals:

- 1. Submit daily jobsite work logs showing which and to what extent construction activities have been affected by weather on a monthly basis.
- 2. Submit actual weather data to support claim for time extension obtained from nearest NOAA weather station or other independently verified source approved by Engineer at beginning of project.
- 3. Use Standard Baseline data provided in this section when documenting actual delays due to weather in excess of the average climatic range.
- 4. Organize claim and documentation to facilitate evaluation on a basis of calendar month periods and submit in accordance with the procedures established in the Contract Documents.
- 5. If an extension of the Contract Time is appropriate, it shall be affected in accordance with the provisions of the General Conditions.

1.20 RESTORATION OF DISTURBED AREAS/WORK ON PRIVATE PROPERTY

- A. In connection with work performed on or adjacent to private property, the Contractor shall take all reasonable care to avoid damage to the property owner's buildings, grounds, and facilities and shall be completely responsible for the repair or damage to same. Fences, hedges, shrubs, etc., within the construction limits shall be carefully removed, preserved, and replaced when the construction is completed. Where ditches or excavations cross lawns with sod, the sod shall be removed carefully and replaced when the backfilling has been completed. If sod is damaged or not handled properly the area shall be restored equal to existing sod at the Contractor's expense. Grassed areas shall be graded, fertilized, and seeded when construction is completed in accordance with the requirements set out in these detailed Specifications. It is intended that when construction is completed the private property owner's facilities and grounds shall be restored to as good as or better than its original condition. Foundations adjacent to an excavation which is to be carried below the bottom of the foundation shall be supported by shoring, bracing or underpinning, and the Contractor shall be held strictly responsible for any damage to said foundation.
- B. Work on the rights-of-way of the State or County Highway Departments shall be considered work on private property. It shall be the Contractor's responsibility to obtain any necessary work permits and to meet all requirements for signs, warning lights, flagmen, etc.
- C. Reasonable care shall be taken during construction to avoid damage to vegetation. Ornamental shrubbery and tree branches shall be temporarily tied back, where appropriate, to minimize damage. Trees which receive damage to branches shall be trimmed of those branches to improve the appearance of the tree. Tree trunks receiving damage from equipment shall be treated with a tree dressing.

1.21 BASIS OF PAYMENT

- A. The Contractor shall furnish all necessary labor, machinery, tools, apparatus, materials, equipment, service, and other necessary supplies and perform all work at the unit prices for the items listed in the bid schedule.
- B. Items listed in the bid schedule constitute all of the pay items for this project; any other items of work listed in the Specifications shown on the plans or required to construct an operable facility shall be considered incidental to those items.
- C. The Contractor shall refer to Section 01 22 00, Measurement and Payment, of these Specifications, for the basis of payment requirements.

1.22 SHOP DRAWINGS

- A. The Contractor shall submit Shop Drawings for all materials to be installed. Shop Drawings shall be submitted in accordance with Section 01 33 23, Shop Drawings, Product Data, and Samples.
- B. Rejection of the same Drawings on 3 separate occasions will constitute grounds for total rejection of the proposed equipment manufacturer or supplier as being unable to meet the Specifications.
- C. Shop Drawings shall be checked by the Contractor and evidence of such checking shall be indicated thereon. The Contractor shall be completely responsible for accuracy, completeness, compliance with plans and Specifications, and compatibility, the Engineer's approval notwithstanding.

1.23 SUPERVISION OF INSTALLATION

- A. All special equipment or materials shall be installed under the supervision of qualified personnel representing the Contractor.

1.24 CONNECTING TO EXISTING LINES

- A. Connections of new lines to existing lines shall be as shown on the plans and/or directed by the Engineer. Work performed in making such connections is considered as incidental and is not a separate pay item, except where bid items are specifically included in the bid schedule.

1.25 FINAL INSPECTION

- A. Final inspection will be held when Contractor notifies the Engineer work is complete and ready for inspection. The Engineer shall contact concerned parties and set a date for the inspection to be held.

1.26 PERMITS, CODES, AGREEMENTS, AND/OR CONTRACTS WITH PRIVATE UTILITIES

- A. The Contractor shall make application for, obtain, and pay for all licenses, permits, agreements, and/or contracts with private utility companies and shall pay all fees and charges in connection therewith. The Contractor shall be responsible for all expenses and fees associated with providing any permanent electric service.

1.27 UTILITIES REQUIRED BY CONTRACTOR

- A. All electric current and/or any utility service required by the Contractor shall be furnished at his/her own expense except as otherwise noted in these Specifications.
- B. The Contractor shall refer to Section 01 50 00, Temporary Construction Facilities and Controls, of these Specifications for additional requirements.

1.28 SUBSURFACE CONDITIONS

- A. Neither the Owner nor the Engineer will be held responsible for subsurface conditions. The Contractor should make his/her own determination concerning the quantities of rock and ground water prior to bidding.

1.29 NOISE AND ODOR CONTROL

- A. Some of the work hereunder is to be performed adjacent to or near private residences, businesses, schools, churches, etc. The Contractor shall be responsible for noise and odor abatement procedures and shall not commence work in these areas before 7:00 a.m. local prevailing time. When necessary, additional work time restrictions may be required.

1.30 CHEMICAL REQUIREMENTS

- A. All chemicals used during project construction or furnished for project operation, whether herbicide, pesticide, disinfectant, reactant or of other classifications, must show approval of either EPA or USDA. Use of all such chemicals and disposal of residues shall be in strict conformance with instructions.

1.31 FIELD REPRESENTATIVE

- A. The Contractor shall have available a responsible on-site representative who can officially receive instructions from the Engineer. The Contractor shall have one complete up-to-date set of plans and Specifications available at all times. The Contractor's failure to comply with this requirement shall cause the Contractor to work at his/her own risk. The jobsite superintendent shall, as a minimum, be provided a mobile telephone.

1.32 EASEMENTS AND WORK ON OR ADJACENT TO PRIVATE PROPERTY

- A. In connection with work performed on or adjacent to private property, the Contractor shall take all reasonable care to avoid damage to the property owner's grounds and facilities and shall be completely responsible for the repair of damage to same. It is intended when construction is completed, the private property owner's facilities and grounds shall be restored to as good or better than their original condition.

1.33 ENGINEER'S AUTHORITY

- A. The Engineer does not have the authority to stop work, order work done or to direct or supervise any of the Contractor's forces.

1.34 PROPERTY INSURANCE

- A. The Builder's Risk insurance described in Document 00 73 14, Supplementary Conditions, shall be purchased and maintained by the Contractor, not the Owner. The policy shall name as the insured the Contractor and the Owner.

1.35 SOIL AND BANK EROSION

- A. The Contractor shall maintain all areas where excavation and backfill operations are being performed or have been performed in order siltation and bank erosion will be kept to a minimum during construction. This requirement includes construction of temporary or permanent erosion barriers and use of special methods to control erosion.

1.36 RETAINAGE REQUIREMENTS

- A. Retainage shall be an amount equal to 5 percent of the payment earned throughout the project until completion. The Owner may, at all times, retain an amount sufficient to cover the estimated cost of the work still to be completed.

PART 2 PRODUCTS (Not Used)

PART 3 EXECUTION (Not Used)

END OF SECTION

PART 1 GENERAL

1.1 SCOPE

- A. The Contractor shall furnish all equipment and labor materials required to provide the Owner with digital construction videos and photographs of the project.
- B. Photo and video files shall become the property of the Owner and none of the videos or photographs shall be published without express permission of the Owner.
- C. These Specifications are only the minimum requirements; actual requirements may be greater depending upon the situation. These Specifications may be adjusted by the sole discretion of the Owner to fit a particular situation not routinely encountered, or as public safety issues become apparent.

1.2 PRE- AND POST-CONSTRUCTION VIDEOS AND PHOTOGRAPHS

- A. Prior to the beginning of any work, the Contractor shall take videos and photographs of the work area to record existing conditions.
- B. Following completion of the work, another set of videos and photographs shall be made showing the same areas and features as in the pre-construction videos and photographs.
- C. All conditions which might later be subject to disagreement shall be shown in sufficient detail to provide a basis for decisions.

1.3 PROGRESS VIDEOS AND PHOTOGRAPHS

- A. The photographs shall include the date and time marking of the recording.

1.4 FILE FORMAT, MEDIA, AND SUBMITTALS

- A. Photographs shall be in “jpg” format.
- B. Videos shall be in a format viewable by Microsoft Windows Media Player or Apple QuickTime Player, audio narration is desirable.
- C. Files shall be named so what is being viewed is self-evident. Videos shall be submitted with a log of the items recorded and referenced to stations and property numbers.
- D. Files shall be submitted on a compact disk (CD) or a digital video disk (DVD). If submitted on DVD, disk shall be recorded in “Minus R” format.
- E. Construction photographs shall be submitted monthly.

PART 2 PRODUCTS (Not Used)

PART 3 EXECUTION (Not Used)

END OF SECTION

PART 1 GENERAL

1.1 SCOPE

- A. The work under this section includes submittal to the Engineer of Shop Drawings, product data, and samples required by the various sections of these Specifications.
- B. Submittal Contents: The submittal contents required are specified in each section.
- C. Definitions: Submittals are categorized as follows:
 - 1. Shop Drawings:
 - a. Shop Drawings shall include technical data, drawings, diagrams, procedure and methodology, performance curves, schedules, templates, patterns, test reports, calculations, instructions, measurements, and similar information as applicable to the specific item for which the Shop Drawing is prepared.
 - b. Provide newly-prepared information, on bond sheets, with graphic information at accurate scale (except as otherwise indicated) or appropriate number of prints hereof, with name of preparer (firm name) indicated. The Contract Drawings shall not be traced or reproduced by any method for use as or in lieu of detail Shop Drawings. Show dimensions and note dimensions that are based on field measurement. Identify materials and products in the work shown. Indicate compliance with standards and special coordination requirements. Do not allow Shop Drawings to be used in connection with the work without appropriate final "Action" markings by the Engineer.
 - c. Drawings shall be presented in a clear and thorough manner. Details shall be identified by reference to sheet and detail, Specification Document, schedule or room numbers shown on the Contract Drawings.
 - d. Minimum assembly drawings sheet size shall be 22 x 34 inches.
 - e. Minimum detail sheet size shall be 8-1/2 x 11 inches.
 - f. Minimum Scale:
 - i.) Assembly Drawings Sheet, Scale: 1-inch = 30 feet.
 - ii.) Detail Sheet, Scale: 1/4-inch = 1 foot.
 - g. Shop drawings may also be provided in electronic .pdf format as authorized by Knox Chapman Utility District.
 - 2. Product Data:
 - a. Product data includes standard printed information on materials, products and systems, not specially prepared for this project, other than the designation of selections from among available choices printed therein.
 - b. Collect required data into 1 submittal for each unit of work or system and mark each copy to show which choices and options are applicable to the project. Include the Manufacturer's standard printed recommendations for application and use, compliance with standards, application of labels and seals, notation of field measurements which have been checked and special coordination requirements.

3. Samples:
 - a. Samples include both fabricated and unfabricated physical examples of materials, products, and units of work, both as complete units and as smaller portions of units of work, either for limited visual inspection or, where indicated, for more detailed testing and analysis.
 - b. Provide units identical with final condition of proposed materials or products for the work. Include “range” samples, not less than 3 units, where unavoidable variations must be expected, and describe or identify variations between units of each set. Provide full set of optional samples where the Engineer’s selection is required. Prepare samples to match the Engineer’s sample where indicated. Include information with each sample to show generic description, source or product name and Manufacturer, limitations, and compliance with standards. Samples are submitted for review and confirmation of color, pattern, texture, and “kind” by the Engineer. Engineer will note “test” samples, except as otherwise indicated, for other requirements, which are the exclusive responsibility of the Contractor.
 4. Miscellaneous submittals related directly to the work (non-administrative) include warranties, maintenance agreements, workmanship bonds, project photographs, survey data and reports, physical work records, statements of applicability, quality testing and certifying reports, copies of industry standards, Record Drawings, field measurement data, operating and maintenance materials, overrun stock, security/protection/safety keys and similar information, devices and materials applicable to the work but not processed as Shop Drawings, product data or samples.
- D. These Specifications are only the minimum requirements; actual requirements may be greater depending upon the situation. These Specifications may be adjusted by the sole discretion of the Owner to fit a particular situation not routinely encountered, or as public safety issues become apparent.

1.2 SPECIFIC CATEGORY REQUIREMENTS

- A. General: Except as otherwise indicated in the individual work sections, comply with general requirements specified herein for each indicated category of submittal. Submittals shall contain:
1. The date of submittal and the dates of any previous submittals.
 2. The project title.
 3. Numerical submittal numbers, starting with 1.0, 2.0, etc. Revisions to be numbered 1.1, 1.2, etc.
 4. The Names of:
 - a. Contractor;
 - b. Supplier; and
 - c. Manufacturer.
 5. Identification of the product, with the Specification Document number, permanent equipment tag numbers, and applicable Drawing No.
 6. Field dimensions clearly identified as such.
 7. Relation to adjacent or critical features of the work or materials.
 8. Applicable standards, such as ASTM or Federal Specification numbers.
 9. Notification to the Engineer in writing, at time of submissions, of any deviations on the submittals from requirements of the Contract Documents.
 10. Identification of revisions on resubmittals.
 11. An 8 x 3-inch blank space for Contractor and Engineer stamps.

12. Contractor's stamp, initialed or signed, certifying to review of submittal, verification of products, field measurements and field construction criteria, and coordination of the information within the submittal with requirements of the work and of Contract Documents.
13. Submittal sheets or Drawings showing more than the particular item under consideration shall have all but the pertinent description of the item for which review is requested crossed out.

1.3 ROUTING OF SUBMITTALS

- A. Submittals and routine correspondence shall be routed as follows:
 1. Supplier to Contractor (through representative, if applicable).
 2. Contractor to Engineer.
 3. Engineer to Contractor and Owner.
 4. Contractor to Supplier.

PART 2 PRODUCTS

2.1 SHOP DRAWINGS

- A. Unless otherwise specifically directed by the Engineer, make all Shop Drawings accurately to a scale sufficiently large enough to show all pertinent features of the item and its method of connection to the work.
- B. Submit all shop assembly drawings, larger than 11 x 17 inches, in PDF format.
- C. Submit all Shop Drawings, 11 x 17 inches and smaller, in PDF format.

2.2 MANUFACTURER'S LITERATURE

- A. Where content of submitted literature from Manufacturers includes data not pertinent to this submittal, clearly indicate which portion of the contents is being submitted for the Engineer's review.
- B. Submit the number of copies which are required to be returned (not to exceed 3) plus 3 copies which will be retained by the Engineer.

2.3 SAMPLES

- A. Samples shall illustrate materials, equipment or workmanship, and established standards by which completed work is judged.
- B. Unless otherwise specifically directed by the Engineer, all samples shall be of the precise article proposed to be furnished.
- C. Submit all samples in the quantity which is required to be returned plus 1 sample which will be retained by the Owner and Engineer.

2.4 COLORS

- A. Unless the precise color and pattern is specifically described in the Contract Documents, wherever a choice of color or pattern is available in a specified product, submit accurate color charts and pattern charts to the Owner and Engineer for review and selection.
- B. Unless all available colors and patterns have identical costs and identical wearing capabilities, and are identically suited to the installation, completely describe the relative costs and capabilities of each.

PART 3 EXECUTION

3.1 CONTRACTOR'S COORDINATION OF SUBMITTALS

- A. Prior to submittal for the Engineer's review, the Contractor shall use all means necessary to fully coordinate all material, including the following procedures:
 - 1. Determine and verify all field dimensions and conditions, catalog numbers, and similar data.
 - 2. Coordinate as required with all trades and all public agencies involved.
 - 3. Submit a written statement of review and compliance with the requirements of all applicable technical Specifications as well as the requirements of this section.
 - 4. Clearly indicate in a letter or memorandum on the Manufacturer's or Fabricator's letterhead, all deviations from the Contract Documents.
- B. Each and every copy of the Shop Drawings and data shall bear the Contractor's stamp showing that they have been so checked. Shop Drawings submitted to the Engineer without the Contractor's stamp will be returned to the Contractor for conformance with this requirement.
- C. The Owner may backcharge the Contractor for costs associated with having to review a particular Shop Drawing, product data or sample more than 2 times to receive a "No Exceptions Taken" mark.
- D. Grouping of Submittals:
 - 1. Unless otherwise specifically permitted by the Engineer, make all submittals in groups containing all associated items.
 - 2. No review will be given to partial submittals of Shop Drawings for items which interconnect and/or are interdependent. It is the Contractor's responsibility to assemble the Shop Drawings for all such interconnecting and/or interdependent items, check them and then make 1 submittal to the Engineer along with Contractor's comments as to compliance, non-compliance or features requiring special attention.
- E. Schedule of Submittals: Within 30 days of contract award and prior to any Shop Drawing submittal, the Contractor shall submit a schedule showing the estimated date of submittal and the desired approval date for each Shop Drawing anticipated. A reasonable period shall be scheduled for review and comments. Time lost due to unacceptable submittals shall be the Contractor's responsibility and some time allowance for resubmittal shall be provided. The schedule shall provide for submittal of items which relate to one another to be submitted concurrently.

3.2 TIMING OF SUBMITTALS

- A. Make all submittals far enough in advance of scheduled dates for installation to provide all required time for reviews, for securing necessary approvals, for possible revision and resubmittal, and for placing orders and securing delivery.
- B. In scheduling, allow sufficient time for the Engineer's review following the receipt of the submittal.

3.3 REVIEWED SHOP DRAWINGS

- A. Engineer Review:
 - 1. Allow a minimum of 30 days for the Engineer's initial processing of each submittal requiring review and response, except allow longer periods where processing must be delayed for coordination with subsequent submittals. The Engineer will advise the Contractor promptly when it is determined that a submittal being processed must be delayed for coordination. Allow a minimum of 2 weeks for reprocessing each submittal. Advise the Engineer on each submittal as to whether processing time is critical to the progress of the work, and therefore the work would be expedited, if processing time could be foreshortened.
 - 2. Acceptable submittals will be marked "No Exceptions Taken".
 - 3. Submittals requiring minor corrections before the product is acceptable will be marked "Make Corrections Noted". The Contractor may order, fabricate, and ship the items included in the submittals, provided the indicated corrections are made. Drawings must be resubmitted for review and marked "No Exceptions Taken" prior to installation or use of products.
 - 4. Submittals marked "Amend and Resubmit" must be revised to reflect required changes and the initial review procedure repeated.
 - 5. The "Rejected – See Remarks" notation is used to indicate products which are not acceptable. Upon return of a submittal so marked, the Contractor shall repeat the initial review procedure utilizing acceptable products.
- B. No work or products shall be installed without a drawing or submittal bearing the "No Exceptions Taken" notation. The Contractor shall maintain at the jobsite a complete set of Shop Drawings bearing the Engineer's stamp.
- C. Substitutions: In the event the Contractor obtains the Engineer's approval for the use of products other than those which are listed first in the Contract Documents, the Contractor shall, at the Contractor's own expense and using methods approved by the Engineer, make any changes to structures, piping, and electrical work that may be necessary to accommodate these products.
- D. Use of the "No Exceptions Taken" notation on Shop Drawings or other submittals is general and shall not relieve the Contractor of the responsibility of furnishing products of the proper dimension, size, quality, quantity, materials and all performance characteristics, to efficiently perform the requirements and intent of the Contract Documents. The Engineer's review shall not relieve the Contractor of responsibility for errors of any kind on the Shop Drawings. Review is intended only to assure conformance with the design concept of the project and

compliance with the information given in the Contract Documents. The Contractor is responsible for dimensions to be confirmed and correlated at the jobsite. The Contractor is also responsible for information that pertains solely to the fabrication processes or to the technique of construction and for the coordination of the work of all trades.

3.4 RESUBMISSION REQUIREMENTS

- A. Shop Drawings:
 - 1. Revise initial Drawings as required and resubmit as specified for initial submittal with the resubmittal number shown.
 - 2. Indicate on Drawings all changes which have been made other than those requested by the Engineer.

- B. Project Data and Samples: Resubmit new data and samples as specified for initial submittal with the resubmittal number shown.

END OF SECTION

PART 1 GENERAL

1.1 SCOPE

- A. This section includes testing which the Owner may require, beyond that testing required of the Manufacturer, to determine if materials provided for the project meet the requirements of these Specifications.
- B. This work also includes all testing required by the Owner to verify work performed by the Contractor is in accordance with the requirements of these Specifications, i.e., concrete strength and slump testing, soil compaction, etc.
- C. This work does not include materials testing required in various sections of these Specifications to be performed by the manufacturer, e.g., testing of pipe.
- D. The testing laboratory or laboratories will be selected by the Owner. The testing laboratory or laboratories will work for the Owner.
- E. These Specifications are only the minimum requirements; actual requirements may be greater depending upon the situation. These Specifications may be adjusted by the sole discretion of the Owner to fit a particular situation not routinely encountered, or as public safety issues become apparent.

1.2 PAYMENT FOR TESTING SERVICES

- A. The cost of testing services required by the contract to be provided by the Contractor shall be paid for by the Contractor, i.e., concrete testing, soil compaction, and asphalt testing.
- B. The cost of additional testing services not specifically required in these Specifications, but requested by the Owner or Engineer, shall be paid for by the Contractor.
- C. The cost of material testing described in various sections of these Specifications or as required in referenced standards to be provided by a material manufacturer, shall be included in the price bid for that item and shall not be paid for by the Owner.
- D. The cost of retesting any item that fails to meet the requirements of these Specifications shall be paid for by the Contractor. Retesting shall be performed by the testing laboratory working for the Owner.

1.3 LABORATORY DUTIES

- A. Cooperate with the Owner, Engineer, and Contractor.
- B. Provide qualified personnel promptly on notice.

- C. Perform specified inspections, sampling, and testing of materials.
 - 1. Comply with specified standards, American Society for Testing and Materials (ASTM), other recognized authorities, and as specified.
 - 2. Ascertain compliance with requirements of the Contract Documents.
- D. Promptly notify the Owner, Engineer, and Contractor of irregularities or deficiencies of work which are observed during performance of services.
- E. Promptly submit 3 copies, 1 copy each to Owner, Engineer, and Contractor of report of inspections and tests in addition to those additional copies required by the Contractor with the following information included:
 - 1. Date issued;
 - 2. Project title and number;
 - 3. Testing laboratory name and address;
 - 4. Name and signature of inspector;
 - 5. Date of inspection or sampling;
 - 6. Record of temperature and weather;
 - 7. Date of test;
 - 8. Identification of product and Specification section;
 - 9. Location of project;
 - 10. Type of inspection or test;
 - 11. Results of test; and
 - 12. Observations regarding compliance with the Contract Documents.
- F. Perform additional services as required.
- G. The laboratory is not authorized to release, revoke, alter or enlarge on requirements of the Contract Documents or approve or accept any portion of the work.

1.4 CONTRACTOR RESPONSIBILITIES

- A. Cooperate with laboratory personnel, provide access to work, and/or comply with manufacturer's requirements.
- B. Provide to the laboratory, representative samples, in required quantities, of materials to be tested.
- C. Furnish copies of mill test reports.
- D. Furnish required labor and facilities to:
 - 1. Provide access to work to be tested;
 - 2. Obtain and handle samples at the site;
 - 3. Facilitate inspections and tests; and
 - 4. Build or furnish a holding box for concrete cylinders or other samples as required by the laboratory.
- E. Notify the laboratory sufficiently in advance of operation to allow for the assignment of personnel and schedules of tests.

- F. Laboratory Tests: Where such inspection and testing are to be conducted by an independent laboratory agency, the sample(s) shall be selected by such laboratory or agency, or the Engineer, and shipped to the laboratory by the Contractor at Contractor's expense.
- G. Copies of all correspondence between the Contractor and testing agencies shall be provided to the Owner and Engineer.

1.5 QUALITY ASSURANCE

- A. Testing shall be in accordance with all pertinent codes and regulations and with procedures and requirements of the ASTM.

1.6 PRODUCT HANDLING

- A. Promptly process and distribute all required copies of test reports and related instructions to insure all necessary retesting or replacement of materials with the least possible delay in the progress of the work.

1.7 FURNISHING MATERIALS

- A. The Contractor shall be responsible for furnishing all materials necessary for testing.

1.8 CODE COMPLIANCE TESTING

- A. Inspections and tests required by codes or ordinances or by a plan approval authority, and made by a legally constituted authority, shall be the responsibility of, and shall be paid for by the Contractor, unless otherwise provided in the Contract Documents.

1.9 CONTRACTOR'S CONVENIENCE TESTING

- A. Inspection or testing performed exclusively for the Contractor's convenience shall be the sole responsibility of the Contractor.

1.10 SCHEDULES FOR TESTING

- A. Establishing Schedule:
 - 1. The Contractor shall, by advance discussion with the testing laboratory selected by the Owner, determine the time required for the laboratory to perform its tests and to issue each of its findings, and make all arrangements for the testing laboratory to be on-site to provide the required testing.
 - 2. Provide all required time within the construction schedule.
- B. When changes of construction schedule are necessary during construction, coordinate all such changes of schedule with the testing laboratory as required.
- C. When the testing laboratory is ready to test according to the determined schedule but is prevented from testing or taking specimens due to incompleteness of the work, all extra costs for testing attributable to the delay will be back-charged to the Contractor and shall not be borne by the Owner.

1.11 TAKING SPECIMENS

- A. Unless otherwise provided in the Contract Documents, all specimens and samples for tests will be taken by the testing laboratory or the Owner or Engineer.

1.12 TRANSPORTING SAMPLES

- A. The Contractor shall be responsible for transporting all samples, except those taken by testing laboratory personnel, to the testing laboratory.

PART 2 PRODUCTS (Not Used)

PART 3 EXECUTION (Not Used)

END OF SECTION

PART 1 GENERAL

1.1 SCOPE

- A. Summary: This section specifies temporary construction facilities and controls including temporary utilities, support, security, and protection facilities.
- B. Regulations: Comply with industry standards and applicable laws and regulations of authorities having jurisdiction including, but not limited to, the following:
 - 1. Building code requirements.
 - 2. Health and safety regulations.
 - 3. Utility company requirements.
 - 4. Police, fire department, and rescue squad regulations and requirements.
 - 5. Environmental protection regulations.
- C. Standards: Comply with NFPA 241 “Standard for Safeguarding Construction, Alterations, and Demolition Operations,” ANSI A10 Series standards for “Safety Requirements for Construction and Demolition,” and NECA Electrical Design Library “Temporary Electrical Facilities.”
 - 1. Electrical Service: Comply with NEMA, NECA, and UL standards and regulations for temporary electric service. Install service in compliance with NFPA 70 “National Electric Code.”
- D. Inspections: Arrange for authorities having jurisdiction to inspect and test each temporary utility before use. Obtain required certifications and permits.
- E. Temporary Utilities: Prepare a schedule indicating dates for implementation and termination of each temporary utility. Submit reports of tests, inspections, meter readings, and procedures performed on temporary utilities. At the earliest time, change over from use of temporary service to use of permanent service. The Contractor is responsible for the payment of all temporary and permanent utility services until Final Acceptance of the Owner.
- F. These Specifications are only the minimum requirements; actual requirements may be greater depending upon the situation. These Specifications may be adjusted by the sole discretion of the Owner to fit a particular situation not routinely encountered, or as public safety issues become apparent.

PART 2 PRODUCTS

2.1 PRODUCTS

- A. Materials: Contractor shall provide new materials. If acceptable in writing by the Owner and Engineer, the Contractor may use undamaged, previously used materials in serviceable condition. Provide materials suitable for use intended.
- B. Water: Potable water approved by local health authorities.

- C. Open-Mesh Fencing: 0.120-inch (3-mm) thick, galvanized 2-inch (50-mm) chain link fabric fencing 6 feet (2 m) high with galvanized barbed-wire top strand and galvanized steel pipe posts, 1.5 inches (38 mm) I.D. for line posts and 2.5 inches (64 mm) I.D. for corner posts.
- D. Equipment: Contractor shall provide new equipment. If acceptable in writing by the Owner and Engineer, the Contractor may use undamaged, previously used equipment in serviceable condition. Provide equipment suitable for use intended.
 - 1. Water Hoses: 3/4-inch (19-mm), heavy-duty, abrasion-resistant, flexible rubber hoses 100 feet (30 m) long. Provide adjustable shut-off nozzles at hose discharge.
 - 2. Electrical Outlets: Properly configured, NEMA-polarized outlets. Provide outlets equipped with ground-fault circuit interrupters, reset button, and pilot light for connection of power tools and equipment.
 - 3. Electrical Power Cords: Grounded extension cords. Use hard-service cords.
 - 4. Lamps and Light Fixtures: General service incandescent lamps. Provide guard cages or tempered-glass enclosures where exposed to breakage. Provide exterior fixtures where exposed to moisture.
 - 5. Heating Units: Temporary heating units that have been tested and labeled by UL, FM or another recognized trade association related to the type of fuel being consumed.
 - 6. Fire Extinguishers: Hand-carried, portable, UL-rated, Class A fire extinguishers for temporary offices and similar spaces. In other locations, provide hand-carried, portable, UL-rated, Class ABC, dry-chemical extinguishers or a combination of extinguishers of NFPA-recommended classes for the exposures.
 - a. Comply with NFPA 10 and NFPA 241 for classification, extinguishing agent, and size required by location and class of fire exposure.

PART 3 EXECUTION

3.1 EXECUTION

- A. Installation, General: Use qualified personnel to install temporary facilities. Locate facilities where they will serve the project adequately and result in minimum interference with performance of work. Relocate and modify facilities as required.
 - 1. Provide each facility ready for use when needed to avoid delay. Maintain and modify as required. Do not remove until facilities are no longer needed or are replaced by authorized use of completed permanent facilities.
 - 2. Conditions of Use: Keep temporary facilities clean and neat in appearance. Operate safely and efficiently. Relocate as the work progresses. Do not overload facilities or permit them to interfere with progress. Take necessary fire prevention measures. Do not allow hazardous, dangerous or unsanitary conditions, or public nuisances to develop or persist onsite. If public nuisances persist and interfere with the progress of work, it is the responsibility of the Contractor to coordinate with the Owner resolution and removal of nuisances.
- B. Temporary Utility Installation: Engage the local utility company to install temporary service or connect to existing service. Where a utility company provides only part of the service; the Contractor shall provide the remainder with matching, compatible materials and equipment at no additional cost to the Owner. The contractor shall comply with utility company recommendations:

1. Arrange with utility company and existing users a time when service can be interrupted to make connections for temporary services.
2. Provide adequate capacity at each stage of construction. Prior to the establishment of temporary utility service, Contractor shall provide trucked-in services at no additional costs to the Owner.
3. Contractor shall obtain easements to bring temporary utilities to the site where the Owner's easements cannot be used for that purpose.
4. Use Charges: Cost or use charges for temporary facilities are not chargeable to the Owner. The Owner will not accept cost or use charges as a basis of claims for Change Orders.
5. Temporary Water Service: Install temporary water service and distribution piping of sizes and pressures adequate for construction. Maintain service until permanent water service is in use. Sterilize piping prior to use.
6. Temporary Electric Power: Provide weatherproof, grounded electric power service and distribution system of sufficient size, capacity, and power characteristics. Include meters, transformers, overload-protected disconnects, automatic ground-fault interrupters, and main distribution switch gear. Install service:
 - a. Power Distribution: Install wiring overhead and rise vertically where least exposed to damage.
 - b. Temporary Lighting: Provide temporary lighting with local switching to fulfill security requirements and illumination of construction operations and traffic conditions.
7. Temporary Heat: Provide temporary heat for curing or drying of completed installations or for protection of installed construction from adverse effects of low temperatures or high humidity. Select equipment that will not have a harmful effect on completed installations. Coordinate ventilation requirements to produce ambient condition required and minimize consumption of energy:
 - a. Heating Facilities: Except where the Owner authorizes use of the permanent system, provide vented, self-contained, LP gas or fuel oil heaters with individual space thermostatic control. Use of gasoline-burning space heaters, open flame or salamander heating units is prohibited.
8. Sanitary Facilities: Comply with regulations and health codes for the type, number, location, operation, and maintenance of fixtures and facilities. Install where facilities will best serve the project's needs. Provide toilet tissue, paper towels, paper cups, and similar disposable materials for each facility. Provide covered waste containers.
 - a. Toilets: Install self-contained, single-occupant toilet units of chemical, aerated recirculation or combustion type. Provide units properly vented and fully enclosed with a glass-fiber-reinforced polyester shell or similar nonabsorbent material. Shield toilets to ensure privacy. Use of pit-type privies will not be permitted.
 - i.) Provide separate facilities for male and female personnel.
 - ii.) Service toilets to ensure that they keep in a clean/usable state.
 - b. Wash Facilities: Install wash facilities supplied with potable water at convenient locations for personnel involved in handling materials that require wash-up. Dispose of drainage properly. Supply cleaning compounds:
 - c. Drinking-Water Facilities: Provide containerized, tap-dispenser, bottled drinking-water units.

9. Sewers and Drainage: If sewers are available, provide temporary connections to remove effluent. If sewers are not available or cannot be used, provide drainage ditches, dry wells, stabilization ponds, and similar facilities. If neither sewers nor drainage facilities can be lawfully used for discharge of effluent, provide containers to remove and dispose of effluent off site in a lawful manner.
 - a. Filter out soil, construction debris, chemicals, and similar contaminants that might clog sewers or pollute waterways.
 - b. Connect temporary sewers to the municipal system, as directed by issuing authorities. Maintain temporary sewers and drainage facilities in a clean, sanitary condition. Following heavy use, restore normal conditions promptly.
 - c. Provide earthen embankments and similar barriers in and around excavations and subgrade construction to prevent flooding by runoff of storm water from heavy rains.

- C. Support Facilities Installation: The Contractor has the option of providing a field office for their use. Locate field offices, storage sheds, and other construction and support facilities for easy access. Maintain facilities until near Substantial Completion. Contractor shall remove all related temporary facilities prior to Substantial Completion. Personnel remaining after Substantial Completion will be permitted to use permanent facilities, under conditions documented in writing by the Owner.
 1. Storage and Fabrication Sheds: Install sheds equipped to accommodate materials and equipment involved. Sheds may be open shelters or fully enclosed spaces within the building.
 2. Temporary Paving: Construct temporary paving for roads, storage areas, and parking where the same permanent facilities will be located.
 - a. Coordinate temporary paving development with grading, compaction, installation, and stabilization of subbase. Install base and finish courses of paving.
 - i.) Install temporary paving to minimize the need to rework the installation. Location and removal of temporary paving shall be coordinated so as not to damage or cause deterioration to permanent facilities that will be occupied by the Owner.
 - b. Extend temporary paving in and around the construction area as necessary to accommodate delivery and storage of materials, equipment usage, administration, and supervision.
 3. Dewatering Facilities and Drains: Contractor shall maintain excavations and construction free of water.
 4. Temporary Enclosures: Provide temporary enclosures for protection of construction from exposure, foul weather, other construction operations, and similar activities. Where heat is needed, and the permanent building enclosure is not complete, provide temporary enclosures where there is no other provision for containment of heat. Coordinate enclosure with ventilating and material drying or curing requirements to avoid dangerous conditions.
 - a. Install tarpaulins securely, with incombustible wood framing and other materials. Close openings of 25 square feet (2.3 sq. m) or less with plywood or similar materials.
 - b. Close openings through floor or roof decks and horizontal surfaces with load-bearing, wood-framed construction.
 5. Temporary Lifts and Hoists: Provide facilities for hoisting materials and employees.

6. Waste Collection and Disposal: Collect waste daily. Comply with requirements of NFPA 241. Enforce requirements strictly. Handle hazardous, dangerous or unsanitary waste materials separately from other waste by containerizing properly. Dispose of material lawfully.
 - a. Do not hold materials more than 7 days during normal weather or 3 days when the temperature is expected to rise above 80° F (27° C).

- D. Security and Protection Facilities Installation: Do not change over from use of temporary security and protection facilities to permanent facilities until acceptance of Substantial Completion by the Owner.
 1. Barricades, Warning Signs, and Lights: Comply with code requirements for erection of barricades. Paint with appropriate colors, graphics, and warning signs. Where appropriate and needed, provide lighting, including flashing red or amber lights.
 2. Enclosure Fence: Before excavation begins, install an enclosure fence with a lockable entrance gate. Refer to Construction Drawings for location.
 - a. Provide open-mesh, chain link fencing and gate with posts set in a compacted mixture of gravel and earth.
 3. Security Enclosure and Lockup: Install temporary enclosure of partially completed areas of construction. Provide locking entrances to prevent unauthorized entrance, vandalism, and theft. Provide a secure lockup where materials and equipment are of value and must be stored.
 4. Environmental Protection: Operate temporary facilities and conduct construction in ways that comply with environmental regulations and minimize the possibility that air, waterways, and subsoil might be contaminated or polluted. Avoid use of tools and equipment that produce harmful noise. Restrict use of noise-making equipment to hours that will minimize complaints.

- E. Operation: Enforce discipline in use of temporary facilities. Limit availability of intended uses to minimize waste and abuse.

- F. Maintenance: Maintain facilities in operating condition until removal. Protect from damage by freezing temperatures and similar elements. Maintain temporary enclosures, heating, cooling, humidity control, ventilation, and similar facilities on a 24-hour basis where required to achieve indicated results and to avoid damage.

- G. Protection: Prevent water-filled piping from freezing. Maintain markers for underground lines. Protect during excavation.

- H. Termination and Removal: Contractor shall remove each temporary facility when the need has ended, when replaced by a permanent facility, or no later than the request for Substantial Completion. Complete or restore permanent construction delayed because of interference with the temporary facility. Repair damaged work, clean exposed surfaces, and replace construction that cannot be satisfactorily repaired:
 1. Materials and temporary facilities are the Contractor's property. The Owner reserves the right to take possession of project identification signs.
 2. Remove temporary paving. Where the area is intended for landscape development, remove soil and aggregate fill that do not comply with requirements for fill or subsoil in the area. Remove materials contaminated with oil, asphalt, and other petrochemical compounds, and substances that might impair growth of plant

materials or lawns. Repair or replace paving, curbs, and sidewalks at the temporary entrances, as required by the governing authority.

3. At time of request for Substantial Completion, clean and renovate permanent facilities used during the construction period.
 - a. Replace air filters and clean inside of ductwork and housings.
 - b. Replace worn parts and parts subject to unusual operating conditions.
 - c. Replace burned out lamps.

END OF SECTION

PART 1 GENERAL

1.1 BARRICADES, LIGHTS, AND SIGNALS

- A. The Contractor shall furnish and erect such barricades, fences, lights, and danger signals and shall provide such other precautionary measures for the protection of persons or property and of the work as necessary. Barricades shall be painted in a color that will be visible at night. From sunset to sunrise, the Contractor shall furnish and maintain at least one light at each barricade and sufficient numbers of barricades shall be erected to keep vehicles from being driven on or into any work under construction.
- B. The Contractor will be held responsible for all damage to the work due to failure of barricades, signs, and lights and whenever evidence is found of such damage, the Contractor shall immediately remove the damaged portion and replace it at Contractor's cost and expense. The Contractor's responsibility for the maintenance of barricades, signs, and lights shall not cease until the project has been accepted by the Owner.
- C. These Specifications are only the minimum requirements; actual requirements may be greater depending upon the situation. These Specifications may be adjusted by the sole discretion of the Owner to fit a particular situation not routinely encountered, or as public safety issues become apparent.

PART 2 PRODUCTS (Not Used)

PART 3 EXECUTION (Not Used)

END OF SECTION

THIS PAGE INTENTIONALLY LEFT BLANK

PART 1 GENERAL

1.1 SCOPE

A. Submittals and Permits:

1. It is the responsibility of the Owner/Developer and Contractor to obtain all permits associated with construction, specifically the Tennessee General Permit (TNR 10-0000) for Storm Water Discharges for Construction Activities. If the disturbed area is greater than 1 acre, the Owner/Developer and Contractor shall provide a Storm Water Pollution Prevention Plan (SWPPP) in accordance with the Tennessee General Permit TNR10-0000. The Owner/Developer and Contractor is responsible for obtaining an individual permit in the event a General Permit is not sufficient. Owner/Developer and Contractor shall prepare and execute a Construction Activity-Storm Water Discharge Notice of Intent (NOI) with the Tennessee Department of Environment and Conservation (TDEC) Field Office.
2. Land disturbance activity shall not commence until the Land Disturbance Permit is issued. The Engineer will provide a copy of plan sheets to the Contractor for Contractor's use. The copy will not bear the Engineer's seal or logo and is provided only for the Contractor's convenience in obtaining land disturbance permits.
3. Description and working Drawings shall indicate controls which will ensure that storm water and drainage from the disturbed jobsite areas, which will be denuded, stripped or modified of its naturally existing or artificially established stabilization or protection against erosion, shall pass through some type of filter system before being discharged. These areas shall be kept sufficiently moist to control dust.
4. Submit a written plan for both temporary and permanent grassing. The plan shall include selection of species, dates, and rates of application for seeding, fertilizer, and mulching.

B. Basic Principles:

1. The Contractor is responsible for inspecting and maintaining all existing erosion and sedimentation control measures.
2. Conduct the earthwork and excavation activities in such a manner to fit the topography, soil type, and condition.
3. Minimize the disturbed area and the duration of exposure to erosion elements.
4. Stabilize disturbed areas immediately.
5. Safely convey run-off from the site to an outlet such that erosion will not be increased off-site.
6. Retain sediment on-site that was generated on-site.
7. Minimize encroachment upon watercourses.

C. Implementation:

1. The erosion and sedimentation control measures shown on the Drawings are minimal requirements. The Contractor's methods of operation may dictate additional erosion and sedimentation control measures not shown on the Drawings which shall be the Contractor's responsibility to determine and install said measures. The Contractor's failure to stabilize disturbed areas immediately following intermediate or final grading may dictate additional erosion and

sedimentation control measures not shown on the Drawings which shall be the Contractor's responsibility to determine and install said measures.

2. The Contractor shall notify the Engineer of any changes and/or additions to the erosion and sedimentation control plan necessary to accommodate the Contractor's methods of operation. No additional payment shall be made for erosion and sedimentation control measures made necessary by the Contractor's methods of operation.
 3. The Contractor shall be solely responsible for control of erosion within the Project site and prevention of sedimentation of any adjacent waterways.
 4. The Contractor shall install controls which will ensure that storm water and drainage from the disturbed area of the Project site shall pass through some type of filter system before being discharged. The filter system must meet the requirements of TDEC.
- D. Temporary Erosion and Sedimentation Control: In general, temporary erosion and sedimentation control procedures shall be directed toward:
1. Preventing soil erosion at the source.
 2. Preventing silt and sediment from entering any waterway if soil erosion cannot be prevented.
 3. Preventing silt and sediment from migrating downstream in the event it cannot be prevented from entering the waterway.
- E. Permanent Erosion Control: Permanent erosion control measures shall be implemented to prevent sedimentation of the waterways and to prevent erosion of the Project site.
- F. These Specifications are only the minimum requirements; actual requirements may be greater depending upon the situation. These Specifications may be adjusted by the sole discretion of Knox Chapman Utility District to fit a particular situation not routinely encountered, or as public safety issues become apparent.

1.2 QUALITY ASSURANCE

- A. General: Perform all work under this section in accordance with all pertinent rules and regulations including, but not necessarily limited to, those stated herein and these Specifications.
- B. Conflicts: Where provisions of pertinent rules and regulations conflict with these Specifications, the more stringent provisions shall govern.

PART 2 PRODUCTS

2.1 TEMPORARY EROSION AND SEDIMENTATION CONTROLS MATERIALS

- A. Silt fence shall meet the requirements of Tennessee Department of Transportation (TDOT), Standard Specification Section 918.27, Geotextile Material, latest edition. Silt fence fabric must be on the TDOT qualified product list for Geotextile (Type III) used for Erosion Control.

- B. Hay bales shall be clean, seed-free cereal hay type.
- C. Netting shall be 1/2-inch, galvanized steel, chicken wire mesh.
- D. Filter stone shall be crushed stone conforming to TDOT Specifications, mineral aggregate size 57.
- E. Concrete block shall be hollow, non-load-bearing type.
- F. Plywood shall be 3/4-inch thick exterior type.
- G. Erosion Control Matting shall be North American Green S-75.

2.2 RIP RAP

- A. Use only one method throughout the Project.
- B. Stone Rip Rap: Use sound, tough, durable stones resistant to the action of air and water. Slabby or shaley pieces will not be acceptable. Specific gravity shall be 2.0 or greater. Rip rap shall have less than 66 percent wear when tested in accordance with AASHTO T-96. Unless shown or specified otherwise, stone rip rap shall be Type 1, Rip Rap.
 - 1. Type A-1 Machined Rip Rap: The pieces shall vary in size from 2 inches to 1-1/4 feet with no more than 20 percent by weight being less than 4 inches. The thickness of the stone layer shall be 1-1/2 feet with a tolerance of 3 inches. Rip rap size shall conform to the TDOT Specification, Section 709.03, Machined Rip Rap, Type A-1.
 - 2. Type A-2 Machined Rip Rap: Shall be identical to Class A-1 except that hand placed rubble stone rip rap placed 1-foot thick in accordance with TDOT Specification Section 709, for Roadway Design, may be substituted for 1-1/2 feet of machined rip rap.
 - 3. Type A-3 Machined Rip Rap: Shall vary in size from 2 inches to 6 inches with no more than 20 percent by weight being less than 4 inches.
- C. Sand-Cement Bag Rip Rap:
 - 1. The bags shall be of cotton, burlap or fiber reinforced paper capable of containing the sand-cement mixture without leakage during handling and placing. Bags previously used for sugar or any other material which will adversely affect the sand-cement mixture shall not be used. Capacity shall be not less than 3/4 cubic foot, nor more than 2 cubic feet.
 - 2. Sand and Portland cement shall be mixed at the maximum ratio of 5:1 by weight and shall obtain a minimum compressive strength of 500 psi in 7 days. For sand-cement bag rip rap, the amount of water used shall be just enough to make up the optimum moisture content of the aggregate and cement, as determined by AASHTO T-134. When sand-cement rip rap is to be pre-bagged, the sand-cement shall be mixed dry, and after placing each course, the bags shall be wet until sufficient moisture is present for proper cement hydration.

2.3 FILTER FABRIC

- A. Silt fence shall meet the requirements of TDOT Specification Section 918.27, Geotextile Material, latest edition. Silt fence fabric must be on the TDOT qualified product list for Geotextile (Type III) used for Erosion Control.

2.4 CONCRETE

- A. Concrete shall have a compressive strength of not less than 3,000 psi, with not less than 5-1/2 bags of cement per cubic yard and a slump between 3 and 5 inches. Ready-mixed concrete shall be mixed and transported in accordance with ASTM C94. Reinforcing steel shall conform to the requirements of ASTM A615, Grade 60.
- B. Provide a concrete mix design for job mixed concrete for the Engineer's approval.

2.5 SILT CURTAIN

- A. Barriers shall be a bright color (yellow or "international" orange are recommended) that will attract the attention of nearby boaters.
- B. Seams in the fabric shall be either vulcanized, welded or sewn, and shall develop the full strength of the fabric.
- C. Flotation devices shall be flexible, buoyant units, contained in an individual flotation sleeve or collar attached to the curtain. Buoyancy provided by the flotation units shall be sufficient to support the weight of the curtain and maintain a freeboard of at least 3 inches above the water surface.
- D. Load lines shall be fabricated into the bottom of all floating turbidity curtains. The top load line shall consist of woven webbing or vinyl-sheathed steel cable and shall have a break strength in excess of 10,000 pounds. The supplemental (bottom) load line shall consist of a chain incorporated into the bottom hem of the curtain, with sufficient weight to serve as ballast to hold the curtain in a vertical position. Additional anchorage shall be provided as necessary. The load lines shall have suitable connecting devices which develop the full breaking strength for connecting to load lines in adjacent sections.
- E. External anchors may consist of wooden or metal stakes (2-inch x 4-inch or 2-1/2-inch minimum diameter wood, or 1.33 pounds/linear foot steel).
- F. Bottom anchors shall be used. Bottom anchors shall be sufficient to hold the curtain in the same position relative to the bottom of the watercourse, without interfering with the action of the curtain. The anchor may dig into the bottom (grappling hook, plow or fluke-type), or may be weighted (mushroom type), and shall be attached to a floating anchor buoy via an anchor line. The anchor line would then run from the buoy to the top load line of the curtain. These lines must contain enough slack to allow the buoy and curtain to float freely with water surface changes without pulling the buoy or curtain down and shall be checked regularly to make sure they do not become entangled with debris. Anchor spacing will vary with current velocity and potential wind and wave action; manufacturer's recommendations shall be followed.

2.6 POLYMER ADDITIVES

- A. Polyacrylamide (PAM) additives are permissible as a supplement to existing Best Management Practices and are not to be relied on as the only method for erosion control.
- B. If the Contractor intends to use PAM additives, they shall provide adequate documentation and testing to show the polymer type and dosing has been matched to the soil type found in the work area. Testing and documentation shall be prepared by the manufacturer of the polymer or other licensed soil professional.
- C. PAM products include but are not limited to additives to the soil, hydro-seeder, treated mat, treated check dams. Due to the different nature of products, manufacturer's directions shall be provided to the Engineer prior to their use. Toxicology reports shall be supplied with all submittal data prior to use.

PART 3 EXECUTION

3.1 GENERAL

- A. Standards: Provide all materials and promptly take all actions necessary to achieve effective erosion and sedimentation control in accordance with TDEC, local enforcing agency guidelines and these Specifications.

3.2 TEMPORARY EROSION AND SEDIMENTATION CONTROL

- A. Temporary erosion and sedimentation control procedures should be initially directed toward preventing silt and sediment from entering the creeks. The preferred method is to provide an undisturbed natural buffer, extending a minimal 25 feet from the top of the bank, to filter the run-off. Should this buffer prove infeasible due to construction activities being too close to the creek, or if the amount of sediment overwhelms the buffer, the Contractor shall place silt fences to filter the run-off and, if necessary, place permanent rip rap to stabilize the creek banks.
- B. Silt dams, silt fences, traps, barriers, check dams, appurtenances, and other temporary measures and devices shall be installed as indicated on the approved plans and permits, shall be maintained until no longer needed, and shall then be removed. Deteriorated hay bales and dislodged filter stone shall be replaced with new materials. Detention ponds, if constructed, shall be maintained in a condition ensuring that unfiltered water will not leave the pond.
- C. Where permanent grassing is not appropriate, and where the Contractor's temporary erosion and sedimentation control practices are inadequate, the Engineer may direct the Contractor to provide temporary vegetative cover with fast growing seedings. Such temporary vegetative cover shall be provided by the Contractor in compliance with TDEC, specifically in the selection of species, planting dates, and application rates for seedings, fertilizer, and mulching, with the exception that kudzu shall not be permitted.

- D. All erosion and sedimentation control devices, including check dams, shall be inspected by the Contractor at least weekly and after each rainfall occurrence and cleaned out and repaired by the Contractor as necessary.
- E. Temporary erosion and sedimentation control devices shall be installed and maintained from the initial land disturbance activity until the satisfactory completion and establishment of permanent erosion control measures. At that time, temporary devices shall be removed.

3.3 PERMANENT EROSION CONTROL

- A. Permanent erosion control shall include:
 - 1. Restoring the work site to its original contours, unless shown otherwise on the Drawings or directed by the Engineer.
 - 2. Permanent vegetative cover shall be performed in accordance with Article 3.4, below.
 - 3. Permanent stabilization of steep slopes and creeks shall be performed in accordance with Article 3.5, below.
- B. Permanent erosion control measures shall be implemented as soon as practical after the completion of pipe installation or land disturbance for each segment of the Project. In no event shall implementation be postponed when no further construction activities will impact that portion or segment of the Project. Partial payment requests may be withheld for those portions of the Project not complying with this requirement.

3.4 GRASSING

- A. General:
 - 1. All references to grassing, unless noted otherwise, shall relate to establishing permanent vegetative cover as specified herein for seeding, fertilizing, mulching, etc.
 - 2. When final grade has been established, all bare soil, unless otherwise required by the Contract Documents, shall be seeded, fertilized, and mulched in an effort to restore to a protected condition. Critical areas shall be sodded as directed by the Engineer.
 - 3. Specified permanent grassing shall be performed at the first appropriate season following establishment of final grading in each section of the site.
 - 4. Permanent grassing shall be of a perennial species.
 - 5. Knox Chapman Utility District staff shall inspect seeding and grassing within 60 days after planting to determine if it is acceptable. If an acceptable growth is not obtained on the first planting, reseeding and remulching will be required.
- B. Replant grass removed or damaged in residential areas using the same variety of grass and at the first appropriate season. Where sod is removed or damaged, replant such areas using sod of the same species of grass at the first appropriate season. Outside of residential or landscaped areas, grass the entire area disturbed by the work on completion of work in any area. In all areas, promptly establish successful stands of grass.
- C. Grassing activities shall comply with TDEC's Specifications, specifically for the selection of species, with the exception that kudzu shall not be permitted, planting dates and application

rates for seeding, fertilizer, and mulching. Where permanent vegetative cover (grassing) cannot be immediately established (due to season or other circumstances) the Contractor shall provide temporary vegetative cover. The Contractor must return to the site (at the appropriate season) to install permanent vegetation in areas that have received temporary vegetative cover.

3.5 RIP RAP

- A. Unless shown otherwise on the Drawings, rip rap shall be placed where ordered by the Engineer, at all points where banks of streams or drainage ditches are disturbed by excavation, or at all points where natural vegetation is removed from banks of the streams or drainage ditches. Carefully compact backfill and place rip rap to prevent subsequent settlement and erosion. This requirement applies equally to construction along side a stream or drainage ditch as well as crossing a stream or drainage ditch.
- B. When trenching across a creek, place rip rap a distance of 10 feet upstream and 10 feet downstream from the top of the trench excavation. Place rip rap across creek bottom, across creek banks, and extend rip rap placement 5 feet beyond the top of each creek bank.
- C. Preparation of Foundations: The ground surface upon which the rip rap is to be placed shall be brought in reasonably close conformity to the correct lines and grades before placement is commenced. Where filling of depressions is required, the new material shall be compacted with hand or mechanical tampers. Unless at creek banks or otherwise shown or specified, rip rap shall begin in a toe ditch constructed in original ground around the toe of the fill or the cut slope. The toe ditch shall be 2 feet deep in original ground, and the side next to the fill or cut shall have that same slope. After the rip rap is placed, the toe ditch shall be backfilled and the excess dirt spread neatly within the construction easement.
- D. Placement of Filter Fabric: The surface to receive fabric shall be prepared to a relatively smooth condition free from obstructions, depressions, and debris. The fabric shall be placed with the long dimension running up the slope and shall be placed to provide a minimum number of overlaps. The strips shall be placed to provide a minimum width of 1 foot of overlap for each joint. The filter fabric shall be anchored in place with securing pins of the type recommended by the Fabric Manufacturer. Pins shall be placed on or within 3 inches of the centerline of the overlap. The fabric shall be placed so that the upstream strip overlaps the downstream strip. The fabric shall be placed loosely so as to give and therefore avoid stretching and tearing during placement of the stones. The stones shall be dropped no more than 3 feet during construction. The fabric shall be protected at all times during construction from clogging due to clay, silts, chemicals or other contaminants. Any contaminated fabric or any fabric damaged during its installation or during placement of rip rap shall be removed and replaced with uncontaminated and undamaged fabric at no expense to the Owner.
- E. Placement of Rip Rap: The rip rap shall be placed on a 6-inch layer of soil, crushed stone or sand overlaying the filter fabric. This 6-inch layer shall be placed to maximize the contact between the soil beneath the filter fabric and the filter fabric. Rip rap shall be placed with its top elevation conforming with the finished grade or the natural slope of the stream bank and stream bottom.
 - 1. Stone Rip Rap: Stone rip rap shall be dumped into place to form a uniform surface and to the thickness specified on the Drawings. The thickness tolerance for the

course shall be -6 inches and +12 inches. If the Drawings or the Bid do not specify a thickness, the course shall be placed to a thickness of not less than 18 inches.

2. Sand-Cement Bag Rip Rap: The bags shall be uniformly filled to the maximum capacity which will permit satisfactory tying. The bagged rip rap shall be placed by hand with the tied ends facing the same direction, with close, broken joints. When directed by the Engineer or required by the Drawings, header courses shall be placed. After placing, the bags shall be rammed or packed against one another to produce the required thickness and form a consolidated mass. The top of each bag shall not vary more than 3 inches above or below the required plane.

END OF SECTION

PART 1 GENERAL

1.1 SCOPE

- A. Close-out requirements for specific construction activities are included in the appropriate Specification sections, Divisions 00 and 01, of the Contract Documents.
- B. These Specifications are only the minimum requirements; actual requirements may be greater depending upon the situation. These Specifications may be adjusted by the sole discretion of the Owner to fit a particular situation not routinely encountered, or as public safety issues become apparent.

1.2 SUBSTANTIAL COMPLETION

- A. Before requesting inspection for certification of Substantial Completion, complete the following:
 - 1. In the Application for Payment that coincides with, or first follows, the date Substantial Completion is claimed, show 100 percent completion for the work claimed as substantially complete.
 - 2. Include supporting documentation for completion and an accounting of changes to the Contract Sum documented by the ledger and/or Change Order forms.
- B. Advise the Owner of pending insurance changeover requirements.
- C. Submit specific warranties, workmanship bonds, maintenance agreements, final certifications, and similar documents.
- D. Submit Record Drawings, maintenance manuals, final project photographs, and similar final record information.
- E. Deliver tools, spare parts, extra stock, and similar items.
- F. Complete final clean-up requirements, including touch-up painting.
- G. Touch-up and repair and restore marred, exposed finishes.

1.3 INSPECTION PROCEDURES

- A. On receipt of a request for inspection of Substantial Completion, the Engineer will proceed or advise the Contractor in writing of unfulfilled requirements. The Engineer will prepare the Certificate of Substantial Completion following inspection or advise the Contractor of construction that must be completed or corrected before the certificate will be issued.
- B. The Engineer will repeat inspection when requested and assured that the work is substantially complete by the Contractor in writing.
- C. Results of the completed inspection will form the basis of requirements for final acceptance.

1.4 FINAL ACCEPTANCE

- A. Before requesting inspection for certification of Final Acceptance and final payment, the Contractor shall complete the following:
 - 1. Final payment request with releases and supporting documentation. Include insurance certificates where required.
 - 2. Submit a statement, accounting for changes to the Contract Sum.
 - 3. Submit a copy of the final inspection punch-list issued at the time of the Substantial Completion inspection stating that each item has been completed or otherwise resolved for acceptance.
 - 4. Submit consent of surety to final payment.
 - 5. Submit a final settlement statement.
 - 6. Submit evidence of continuing insurance coverage complying with insurance requirements.

1.5 REINSPECTION PROCEDURE

- A. The Engineer will reinspect the work upon receipt of written notice by the Contractor that the work has been completed, except for items whose completion is delayed under circumstances acceptable to the Engineer.
- B. Upon completion of reinspection, the Engineer will prepare a certificate of Final Acceptance. If the work is incomplete, the Engineer will advise the Contractor of work that is incomplete or obligations that have not been fulfilled but are required.
- C. If necessary, reinspection will be repeated at additional cost to the Contractor.

1.6 RECORD DOCUMENT SUBMITTALS

- A. Contractor shall not use Record Documents for construction. Contractor shall protect Record Documents from loss in a secure location. Contractor shall furnish Record Documents to the Engineer at time for request of Substantial Completion. Contractor shall provide access to Record Documents throughout the duration of the project for the Engineer's reference.

1.7 RECORD DRAWINGS

- A. Contractor shall maintain a set of prints of Contract Drawings, Shop Drawings, and submittals on-site. It is the responsibility of the Contractor to mark the set of Construction Documents to show the actual installation of all site elements where the installation varies substantially from the work as originally shown. Mark the Drawings in a manner that depicts conditions fully and accurately, including all sub-surface elements.
- B. Mark all Drawings with a red pencil. Use other colors where necessary to distinguish between variations in separate categories of work.
- C. Organize Record Drawing sheets into manageable sets. Bind with durable-paper cover sheets, print titles, dates, and other identification on the cover of each set.

- D. Upon completion of the work, submit one reproducible copy of the Record Drawings, Shop Drawings, and submittals to the Engineer for the Owner's records. (Refer to Special Conditions for as-built Drawing requirements.)

1.8 RECORD SPECIFICATIONS

- A. Contractor shall maintain one copy of the Project Manual Specifications, including addenda, on-site. It is the responsibility of the Contractor to mark variations in work performed in comparison with the text of the Specifications and modifications. Give attention to substitutions, selection of options, and information on sub-surface site element construction. Note related Record Drawing, Shop Drawing, and submittal information, as well as product data.
- B. Upon completion of the work, submit record Project Manual Specifications to the Engineer for the Owner's records.
- C. Submit complete copies of all testing data records to the Engineer for the Owner's records.

1.9 REMOVAL OF PROTECTION

- A. Remove temporary site security, protection, and facilities.

1.10 COMPLIANCE

- A. Comply with regulations of authorities having jurisdiction and safety standards for cleaning. Remove waste materials and dispose of lawfully.

PART 2 PRODUCTS (Not Used)

PART 3 EXECUTION (Not Used)

END OF SECTION

THIS PAGE INTENTIONALLY LEFT BLANK

PART 1 GENERAL

1.1 SCOPE

- A. The Contractor shall provide a complete and comprehensive reference manual (Operating and Maintenance (O&M) Manual) containing operating and maintenance data to enable operators and plant engineers to correctly operate, service, and maintain all equipment and accessories covered by these Specifications and Drawings. The data contained in the manual shall explain and illustrate clearly and simply all principles and theory of operation, operating instructions, maintenance procedures, calibration procedures, and safety precautions and procedures for the equipment involved.
- B. No separate payment will be made for the O&M Manual and the cost of said manual shall be included in the Contract Price.
- C. These Specifications are only the minimum requirements; actual requirements may be greater depending upon the situation. These Specifications may be adjusted by the sole discretion of the Owner to fit a particular situation not routinely encountered, or as public safety issues become apparent.

1.2 SUBMITTAL SCHEDULE

- A. The Contractor shall submit, for the Engineer's approval, 2 preliminary hard copies of the O&M Manual with all specified material before the work covered by these Contract Documents is 80 percent complete. The Engineer will notify the Contractor, in writing, of any deficiencies in the manual and will return 1 copy of the manual for completion and/or correction.
- B. Before final acceptance, the Contractor shall submit 2 hard copies and 1 electronic copy of the revised O&M Manual, complete in detail as specified below.
- C. Digital Copies of Manuals: O&M Manuals shall be provided by the Contractor in digital format. Materials available in digital format shall be furnished in accordance with the following:
 - 1. All textual data shall be provided as an electronic file in searchable Adobe Acrobat Portable Document Format (PDF). The PDF file(s) shall be fully indexed using the Table of Contents, searchable with thumbnails generated. File(s) shall be identified by utilization of an "eight dot three" convention (XXXXX.YY.pdf) where X is the 5-digit number corresponding to the Specification Section, and YY is an identification number. All documents shall be scanned at 300dpi or greater utilizing optical character recognition (OCR) software. All text in the document must be text selectable with the exception of pages which are in their entirety drawings or diagrams. Word searches of the PDF document must function successfully. PDF files that fail to comply with the indexing and searchable features described above will not be acceptable. All drawing data shall be provided in digital format compatible with AutoCAD Version 14.

2. Materials not available in original digital format (available only in paper format) shall be scanned as noted above into a PDF format and cleaned to remove smudges, fingerprints, artifacts, and other extraneous marks. All notes, version stamps, etc. shall be preserved. Color maps shall be scanned in not less than the number of colors of the document or 16 colors, whichever is greater. Color photographs shall be saved in not less than 256 colors. Black and white or monochrome scans (non-text) shall not be less than 16 gray scale levels. Color maps, color photographs, and black and white and gray scale photograph files shall be saved as GIF or JPG files, compatible with Adobe Photoshop Version 4.0. Documents shall be scanned in the existing color format of the document, i.e., color documents shall be scanned in color, and black and white or monochrome in gray scale.
3. After the documents are in correct digital format, they shall be furnished to the Engineer as a 120 mm, 680mb, 74-minute CD ROM or USB removable drive. All media transmittals shall be accompanied by a detailed paper printout of the files on the media. This printout shall consist of a file name, file size, date of creation, submittal number, and a brief but accurate description of the file. Files shall not be transmitted by modem. One (1) copy of the CD for each O&M Manual shall be provided to the Engineer.

1.3 SUBMITTAL FORMAT

- A. Each copy of the manual shall be assembled in 1 or more loose leaf binders, each with title page, typed table of contents, typed list of tables, typed list of figures, and heavy section dividers with reinforced holes and numbered plastic index tabs. Binders shall be 3-ring, hardback type, with transparent vinyl pocket front cover suitable for inserting identifying cover and with a transparent vinyl pocket on the spine for label. All data shall be punched for binding. Composition and printing shall be arranged so that punching does not obliterate any data. The cover and binding edge of each manual shall have the project title, Specification Section number and title, and manual title printed thereon, all as approved by the Engineer.
- B. All copies of Shop Drawings, figures, and diagrams shall be reduced to either 8-1/2 x 11 inches or to 11 inches in the vertical dimension and as near as practical to 17 inches in the horizontal dimensions. Such sheets shall be folded to 8-1/2 x 11 inches. The manual and other data shall be printed on first quality paper, 8-1/2 x 11-inch size with standard 3-hole punching. Binders shall be labeled Vol. 1, Vol. 2, etc., where more than one is required. The table of contents for the entire set, identified by volume number, shall appear in each binder. Text, figures, and drawings shall be clearly legible and suitable for dry process reproductions.
- C. Each submittal shall have a cover sheet that includes the following information:
 1. The date of submittal and the dates of any previous submittals;
 2. The project title;
 3. Numerical submittal numbers, starting with 1.90, 2.90, etc. Revisions to be numbered 1.91, 1.92, etc.;
 4. The names of the:
 - a. Contractor;
 - b. Supplier; and
 - c. Manufacturer.
 5. Identification of the product, with the Specification Section number, permanent equipment tag numbers, and applicable drawing number.

- D. The Engineer will not recommend final acceptance of the work until the O&M Manual is complete and satisfactory to Engineer.

1.4 CONTENTS OF OPERATING AND MAINTENANCE MANUAL

- A. Each O&M Manual shall include a title page which includes all information specified in Article 1.3, Paragraph C., above. In addition, the title page shall include the Manufacturer's address, phone number, facsimile number, and contact; Manufacturer's equipment name and model number; supplier's address, phone number, facsimile number, and contact.
- B. Each O&M Manual shall include a table of contents identifying the location of each item listed below, for each component supplied. For items not applicable to a component, the table of contents shall list N/A for the page number.
- C. For all equipment, the Contractor shall furnish a complete, detailed listing of all equipment, components, and accessories showing component name, Manufacturer, model number, and quantity information shall be furnished for each component as outlined below:
 - 1. Equipment function, normal operating characteristics, performance data, and limiting conditions.
 - 2. Detailed disassembly, overhaul and reassembly, installation, alignment, adjustment, and checking instructions.
 - 3. Detailed operating instructions for start-up, calibration, routine and normal operation, regulation and control, safety, shut-down and emergency conditions. Detailed list of settings for relays, pressure switches, temperature switches, level switches, thermostats, alarms, relief valves, rupture discs, etc.
 - 4. Detailed preventative maintenance procedures and schedules, including detailed lubrication instructions and schedules, identification of required lubricants and operating fluids (description, specification, and trade name of at least 2 Manufacturers), and diagrams illustrating lubrication points.
 - 5. Detailed guide to "troubleshooting".
 - 6. Detailed parts lists identified by title, materials of construction, Manufacturer's part number, list of recommended spare parts identified as specified above, predicted life of parts subject to wear, and an exploded or concise cut-away view of each equipment assembly.
 - 7. Electrical and instrumentation schematics, including motor control centers, control panels, instrument panels, and analyzer panels.
 - 8. List of all special tools supplied and description of their use. Special tools include any tool not normally available in an industrial hardware or mill supply house.
 - 9. List of names and addresses of nearest service centers for parts, overhaul, and service.
 - 10. Procedures for storing, handling, and disposing of any chemicals or products used with the equipment or system.
 - 11. The supplier's operation and maintenance information will address the particular equipment furnished, with specific details on operation and maintenance practices. General data is not acceptable. Information contained in the manual which is not acceptable to the project shall be marked out and noted as "N/A".

PART 2 PRODUCTS (Not Used)

PART 3 EXECUTION (Not Used)

END OF SECTION

PART 1 GENERAL

1.1 SCOPE

- A. These Specifications are only the minimum requirements; actual requirements may be greater depending upon the situation. These Specifications may be adjusted by the sole discretion of the Owner to fit a particular situation not routinely encountered, or as public safety issues become apparent.

1.2 PROJECT MAINTENANCE AND WARRANTY

- A. Maintain and keep in good repair the work covered by these Drawings and Specifications until acceptance by the Owner.
- B. The Contractor shall warrant for a period of one year from the date of Owner's written final acceptance of the Project, as defined in the Contract Documents, that the completed work is free from all defects due to faulty products or workmanship and the Contractor shall promptly make such corrections as may be necessary by reason of such defects. The Owner will give notice of observed defects with reasonable promptness. In the event that the Contractor should fail to make such repairs, adjustments or other work that may be made necessary by such defects, the Owner may do so and charge the Contractor the cost thereby incurred. The Performance Bond shall remain in full force and effect throughout the warranty period.
- C. The Contractor shall not be obligated to make replacements which become necessary because of ordinary wear and tear, or as a result of improper operation or maintenance, or as a result of improper work or damage by another Contractor or the Owner, or to perform any work which is normally performed by a maintenance crew during operation.
- D. In the event of multiple failures of major consequences prior to the expiration of the 1-year warranty described above, the affected unit shall be disassembled, inspected, and modified or replaced as necessary to prevent further occurrences. All related components which may have been damaged or rendered non-serviceable as a consequence of the failure shall be replaced. A new 12-month warranty against defective or deficient design, workmanship, and materials shall commence on the day that the item is reassembled and placed back into operation. As used herein, multiple failure shall be interpreted to mean 2 or more successive failures of the same kind in the same item or failures of the same kind in 2 or more items. Major failures may include, but are not limited to, cracked or broken housings, piping or vessels, excessive deflections, bent or broken shafts, broken or chipped gear teeth, premature bearing failure, excessive wear or excessive leakage around seals. Failures which are directly and clearly traceable to operator abuse, such as operations in conflict with published operating procedures or improper maintenance, such as substitution of unauthorized replacement parts, use of incorrect lubricants or chemicals, flagrant over- or under-lubrication and using maintenance procedures not conforming with published maintenance instructions, shall be exempted from the scope of the 1-year warranty. Should multiple failures occur in a given item, all products of the same size and type shall be disassembled, inspected, modified or replaced as necessary and rewarranted for one year.

- E. The Contractor shall, at Contractor's own expense, furnish all labor, materials, tools, and equipment required and shall make such repairs and removals and shall perform such work or reconstruction as may be made necessary by any structural or functional defect or failure resulting from neglect, faulty workmanship or faulty materials, in any part of the work performed by the Contractor. Such repair shall also include refilling of trenches, excavations or embankments which show settlement or erosion after backfilling or placement.
- F. Except as noted on the Drawings or as specified, all structures such as embankments and fences shall be returned to their original condition prior to the completion of the Contract. Any and all damage to any facility not designated for removal, resulting from the Contractor's operations, shall be promptly repaired by the Contractor at no cost to the Owner.
- G. The Contractor shall be responsible for all road and entrance reconstruction and repairs and maintenance of same for a period of 1 year from the date of final acceptance. In the event the repairs and maintenance are not made immediately, and it becomes necessary for the owner of the road to make such repairs, the Contractor shall reimburse the owner of the road for the cost of such repairs.
- H. In the event the Contractor fails to proceed to remedy the defects upon notification within 15 days of the date of such notice, the Owner reserves the right to cause the required materials to be procured and the work to be done, as described in the Drawings and Specifications, and to hold the Contractor and the sureties on Contractor's bond liable for the cost and expense thereof.
- I. Notice to Contractor for repairs and reconstruction will be made in the form of a registered letter addressed to the Contractor at Contractor's home office.
- J. Neither the foregoing paragraphs nor any provision in the Contract Documents, nor any special guarantee time limit implies any limitation of the Contractor's liability within the law of the place of construction.

PART 2 PRODUCTS (Not Used)

PART 3 EXECUTION (Not Used)

END OF SECTION

PART 1 GENERAL**1.1 SCOPE**

- A. The work under this section includes, but is not necessarily limited to, the compiling, maintaining, recording, and submitting of project Record Documents as herein specified.
- B. Record Documents include, but are not limited to:
 - 1. Drawings;
 - 2. Specifications;
 - 3. Change Orders and other modifications to the Contract;
 - 4. Engineer field orders or written instructions, including Requests for Information (RFI) and clarification memorandums;
 - 5. Reviewed Shop Drawings, product data, and samples; and
 - 6. Test records.
- C. The Contractor shall maintain on the project site throughout the Contract time an up-to-date set of Record Drawings.
- D. These Specifications are only the minimum requirements; actual requirements may be greater depending upon the situation. These Specifications may be adjusted by the sole discretion of the Owner to fit a particular situation not routinely encountered, or as public safety issues become apparent.

1.2 MAINTENANCE DOCUMENTS AND SAMPLES

- A. Storage:
 - 1. Store documents and samples in the Contractor's field office, apart from documents used for construction;
 - 2. Provide files and racks for storage of documents; and
 - 3. Provide locked cabinet or secure storage space for storage of samples.
- B. File documents and samples in accordance with format of these Specifications.
- C. Maintenance:
 - 1. Maintain documents in a clean, dry, legible condition, and in good order;
 - 2. Do not use Record Documents for construction purposes; and
 - 3. Maintain at the site for the Owner one copy of all Record Documents.
- D. Make documents and samples available at all times for inspection by Engineer.
- E. Failure to maintain the Record Documents in a satisfactory manner may be cause for withholding of a certificate for payment.

1.3 QUALITY ASSURANCE

- A. Unless noted otherwise, Record Drawings shall provide dimensions, distances, and coordinates to the nearest 0.1 foot.

- B. Unless noted otherwise, Record Drawings shall provide elevations to the nearest 0.01 foot for all pertinent items constructed by the Contractor.

1.4 RECORDING

- A. Label each document “Project Record” in neat, large-printed letters.
- B. Recording:
 - 1. Record information concurrently with construction progress; and
 - 2. Do not conceal any work until required information is recorded.

1.5 RECORD DRAWINGS

- A. Record Drawings shall be reproducible, shall have a title block indicating that the Drawings are Record Drawings, the name of the company preparing the Record Drawings, and the date the Record Drawings were prepared.
- B. Legibly mark Drawings to record actual construction, including:
 - 1. All Construction:
 - a. Changes of dimension and detail;
 - b. Changes made by RFI, field order, clarification memorandums or by Change Order; and
 - c. Details not on original Drawings.

1.6 SPECIFICATIONS

- A. Legibly mark each section to record:
 - 1. Manufacturer, trade name, catalog number, and Supplier of each product and item of equipment actually installed; and
 - 2. Changes made by RFI, field order, clarification memorandums or by Change Order.

1.7 SUBMITTAL

- A. At Contract close-out, deliver Record Documents to the Engineer for the Owner.
- B. Accompany submittal with transmittal letter, in duplicate, containing:
 - 1. Date;
 - 2. Project title and number;
 - 3. Contractor’s name and address;
 - 4. Title and number of each Record Document; and
 - 5. Signature of Contractor or Contractor’s authorized representative.

PART 2 PRODUCTS (Not Used)

PART 3 EXECUTION (Not Used)

END OF SECTION

PART 1 GENERAL

1.1 SCOPE

- A. Clearing and grubbing includes, but is not limited to, removing from the project site: trees, stumps, roots, brush, structures, abandoned utilities, trash, debris, and all other materials found on or near the surface of the ground in the construction area and understood by generally accepted engineering practice not to be suitable for construction of the type contemplated. Precautionary measures that prevent damage to existing features to remain are part of the work.
- B. Clearing and grubbing operations shall be coordinated with temporary and permanent erosion and sedimentation control procedures.
- C. These Specifications are only the minimum requirements; actual requirements may be greater depending upon the situation. These Specifications may be adjusted by the sole discretion of the Owner to fit a particular situation not routinely encountered, or as public safety issues become apparent.

1.2 QUALITY ASSURANCE

- A. The Contractor shall comply with applicable codes, ordinances, rules, regulations, and laws of local, municipal, state or federal authorities having jurisdiction over the project. All required permits of a temporary nature shall be obtained for construction operations by the Contractor.
- B. Open burning, if allowed, shall first be permitted by the local authority having jurisdiction. The Contractor shall notify the local fire department and abide by fire department restrictions.

1.3 JOB CONDITIONS

- A. Location of the Work: The area to be cleared and grubbed is shown schematically on the Drawings or specified below. It includes all areas designated for construction.

PART 2 PRODUCTS

2.1 EQUIPMENT

- A. The Contractor shall furnish equipment of the type normally used in clearing and grubbing operations including, but not limited to, tractors, trucks, and loaders.

PART 3 EXECUTION

3.1 SCHEDULING OF CLEARING

- A. The Contractor shall clear at each construction site only that length of the right-of-way, permanent or construction easement which would be the equivalent of one month's pipe laying. This length shall be determined from the Contractor's Progress Schedule.
- B. The Engineer may permit clearing for additional lengths of the pipeline provided that temporary erosion and sedimentation controls are in place and a satisfactory stand of temporary grass is established. Should a satisfactory stand of grass not be possible, no additional clearing shall be permitted beyond that specified above.
- C. A satisfactory stand of grass shall have no bare spots larger than 1 square yard. Bare spots shall be scattered, and the bare area shall not comprise more than 1 percent of any given area.

3.2 CLEARING AND GRUBBING

- A. Clear and grub, as required, on each side of the pipeline before excavating. Remove all trees, growth, debris, stumps, and other objectionable matter. Clear the construction easement or road right-of-way only, if necessary.
- B. Materials to be cleared, grubbed, and removed from the project site include, but are not limited to, all trees, stumps, roots, brush, trash, organic matter, paving, miscellaneous structures, houses, debris, and abandoned utilities.
- C. Grubbing shall consist of completely removing roots, stumps, trash, and other debris from all graded areas so that topsoil is free of roots and debris. Topsoil is to be left sufficiently clean so that further picking and raking will not be required.
- D. All stumps, roots, foundations, and planking embedded in the ground shall be removed and disposed of. Piling and butts of utility poles shall be removed to a minimum depth of 2 feet below the limits of excavation for structures, trenches, and roadways or 2 feet below finish grade, whichever is lower.
- E. Landscaping features shall include, but are not necessarily limited to, fences, mailboxes, cultivated trees, cultivated shrubbery, property corners, man-made improvements, subdivision, and other signs within the right-of-way and easement. The Contractor shall take extreme care in moving landscape features and promptly reestablishing these features.
- F. Surface rocks and boulders shall be grubbed from the soil and removed from the site, if not suitable as rip rap.
- G. Where the tree limbs interfere with utility wires, or where the trees to be felled are in close proximity to utility wires, the tree shall be taken down in sections to eliminate the possibility of damage to the utility.

- H. Any work pertaining to utility poles shall comply with the requirements of the appropriate utility.
- I. All fences adjoining any excavation or embankment that, in the Contractor's opinion, may be damaged or buried, shall be carefully removed, stored, and replaced. Any fencing that, in the Engineer's or Owner's opinion, is significantly damaged shall be replaced with new fence material.
- J. The Contractor shall exercise special precautions for the protection and preservation of trees, cultivated shrubs, sod, fences, etc., situated within the limits of the construction area but not directly within excavation and/or fill limits. The Contractor shall be held liable for any damage the Contractor's operations have inflicted on such property.
- K. The Contractor shall be responsible for all damages to existing improvements resulting from Contractor's operations.

3.3 DISPOSAL OF DEBRIS

- A. The debris resulting from the clearing and grubbing operation shall be hauled to a disposal site secured by the Contractor and shall be disposed of in accordance with all requirements of federal, state, county, and municipal regulations. No debris of any kind shall be deposited in any stream or body of water, or in any street or alley. No debris shall be deposited upon any private property except with written consent of the property owner. In no case shall any material or debris be left on the project site, shoved onto abutting private properties or buried on the project site.
- B. When approved in writing by the Engineer or Owner and when authorized by the proper authorities, the Contractor may dispose of such debris by burning on the project site provided all requirements set forth by the governing authorities are met. The authorization to burn shall not relieve the Contractor in any way from damages which may result from Contractor's operations. On easements through private property, the Contractor shall not burn on the site unless written permission is also secured from the property owner, in addition to authorization from the proper authorities.

END OF SECTION

THIS PAGE INTENTIONALLY LEFT BLANK

PART 1 GENERAL**1.1 SCOPE**

- A. The work under this section consists of furnishing all labor, equipment, and materials and performing all operations in connection with the trench excavation and backfill required to install the pipelines shown on the Drawings and as specified.
- B. Excavation shall include the removal of any trees, stumps, brush, debris or other obstacles which remain after the clearing and grubbing operations, which may obstruct the work, and the excavation and removal of all earth, rock or other materials to the extent necessary to install the pipe and appurtenances in conformance with the lines and grades shown on the Drawings and as specified.
- C. Backfill shall include the refilling and compaction of the fill in the trenches and excavations up to the surrounding ground surface or road grade at crossing.
- D. The trench is divided into 5 specific areas:
 - 1. Foundation: The area beneath the bedding, sometimes also referenced to as trench stabilization.
 - 2. Bedding: The area above the trench bottom (or foundation) and below the bottom of the barrel of the pipe.
 - 3. Haunching: The area above the bottom of the barrel of the pipe up to a specified height above the bottom of the barrel of the pipe.
 - 4. Initial Backfill: The area above the haunching material and below a plane 12 inches above the top of the barrel of the pipe.
 - 5. Final Backfill: The area above a plane 12 inches above the top of the barrel of the pipe.
- E. The choice of method, means, techniques, and equipment rests with the Contractor. The Contractor shall select the method and equipment for trench excavation and backfill depending upon the type of material to be excavated and backfilled, the depth of excavation, the amount of space available for operation of equipment, storage of excavated material, proximity of man-made improvements to be protected, available easement or right-of-way, and prevailing practice in the area.
- F. These Specifications are only the minimum requirements; actual requirements may be greater depending upon the situation. These Specifications may be adjusted by the sole discretion of the Knox Chapman Utility District to fit a particular situation not routinely encountered, or as public safety issues become apparent.

1.2 QUALITY ASSURANCE

- A. Density: All references to “maximum dry density” shall mean the maximum dry density defined by ASTM D698, “Maximum Density-Optimum Moisture Test”. Determination of the density of foundation, bedding, haunching or backfill materials in place shall meet the requirements of ASTM D1556, “Density of Soil in Place by the Sand Cone Method”;

ASTM D2937, “Density of Soil in Place by the Drive-Cylinder Method”; or ASTM D6938, “In-Place Density and Water Content of Soil and Soil Aggregate by Nuclear Methods Shallow Depth”.

- B. Sources and Evaluation Testing: Testing of materials to certify conformance with the Specifications shall be performed by an independent testing laboratory at no cost to the Owner. The Contractor’s testing laboratory shall perform tests, at no cost to the Owner, upon change of source and at sufficient intervals during the work to certify conformance of all select material furnished for use on this project.

1.3 SAFETY

- A. Perform all trench excavation and backfilling activities in accordance with the Occupational Safety and Health Act of 1970 (PL 91-596), as amended. The Contractor shall pay particular attention to the Safety and Health Regulations Part 1926, Subpart P “Excavation, Trenching & Shoring”, as described in OSHA Publication 2226. All trench safety is the responsibility of the Contractor.

PART 2 PRODUCTS

2.1 TRENCH FOUNDATION MATERIALS

- A. Crushed stone or surge stone shall be utilized for trench foundation (trench stabilization).
- B. Crushed stone shall be crushed limestone and shall meet the requirements of the Tennessee Department of Transportation (TDOT) Specification 903. Stone size shall be between 1/2-inch and No. 4, inclusive, as determined by TDOT Specification 903.22.
- C. Surge stone shall be crushed limestone and shall meet the requirements of TDOT Specification 903. Stone size shall be No. 1, inclusive, as determined by TDOT Specification 903.22.

2.2 BEDDING AND HAUNCHING MATERIALS

- A. Unless specified otherwise, bedding and haunching materials shall be crushed stone or earth materials as specified below.
- B. Crushed stone utilized for bedding and haunching shall meet the requirements of TDOT Specification 903. Stone size shall be No. 7, as determined by TDOT Specification 903.22.
- C. Earth materials utilized for bedding and haunching shall be suitable materials selected from materials excavated from the trench. Suitable materials shall be clean and free of rock larger than 2 inches at its largest dimension, organics, cinders, stumps, limbs, frozen earth or mud, man-made wastes, and other unsuitable materials. Should the material excavated from the trench be saturated, the saturated material may be used as earth material, provided it is allowed to dry properly, and it is capable of meeting the specified compaction requirements. When necessary, earth bedding and haunching materials shall be moistened to facilitate compaction by tamping. If materials excavated from the trench are not suitable for use as

bedding or haunching material, provide select material conforming to the requirements of this section at no additional cost to the Owner.

2.3 INITIAL BACKFILL

- A. Unless shown on Drawings or specified otherwise, initial backfill material shall be crushed stone or earth materials as specified for bedding and haunching materials.
- B. Earth materials utilized for initial backfill shall be suitable materials selected from materials excavated from the trench. Suitable materials shall be clean and free of rock larger than 2 inches at its largest dimension, organics, cinders, stumps, limbs, frozen earth or mud, man-made wastes, and other unsuitable materials. Should the material excavated from the trench be saturated, the saturated material may be used as earth material, provided it is allowed to dry properly, and it is capable of meeting the specified compaction requirements. When necessary, initial backfill materials shall be moistened to facilitate compaction by tamping. If materials excavated from the trench are not suitable for use as initial backfill material, provide select material conforming to the requirements of this section.

2.4 FINAL BACKFILL

- A. Final backfill material shall be general excavated earth materials, shall not contain rock larger than 3 inches at its greatest diameter, cinders, stumps, limbs, man-made wastes, and other unsuitable materials. If materials excavated from the trench are not suitable for use as final backfill material, provide select material conforming to the requirements of this section.
- B. Final backfill under roads will be crushed stone or flowable fill meeting the requirements of the Highway Department with jurisdictional authority. If a conflict occurs between requirements, the stricter shall apply.

2.5 SELECT BACKFILL

- A. Select backfill shall be materials which meet the requirements as specified for bedding, haunching, initial backfill or final backfill materials, including compaction requirements.

2.6 CONCRETE

- A. Concrete for bedding, haunching, initial backfill or encasement shall have a compressive strength of not less than 3,000 psi, with not less than 5-1/2 bags of cement per cubic yard and a slump between 3 to 5 inches. Ready-mixed concrete shall be mixed and transported in accordance with ASTM C94. Reinforcing steel shall conform to the requirements of ASTM A615, Grade 60.

2.7 FLOWABLE FILL

- A. Flowable fill for final backfill shall not have a compressive strength exceeding 150 psi, with not less than 100 pounds of cement per cubic yard, and a minimum of 250 pounds of Class C or F, Fly Ash, per cubic yard. Flowable fill shall be mixed and transported in accordance with ASTM C94.

PART 3 EXECUTION

3.1 TRENCH EXCAVATION

- A. Topsoil and grass shall be stripped a minimum of 6 inches over the trench excavation site and stockpiled separately for replacement over the finished grading areas.
- B. Trenches shall be excavated to the lines and grades shown on the Drawings with the centerlines of the trenches on the centerlines of the pipes and to the dimensions which provide the proper support and protection of the pipe and other structures and accessories.
- C. Trench Width for Pipelines:
 - 1. The sides of all trenches shall be vertical to a minimum of 1 foot above the top of the pipe. Unless otherwise indicated on the Drawings, the maximum trench width shall be equal to the sum of the outside diameter of the pipe plus 2 feet.
 - 2. Excavate the top portion of the trench to any width within the construction easement or right-of-way which will not cause unnecessary damage to adjoining structures, roadways, pavement, utilities, trees or private property. Where necessary to accomplish this, provide sheeting and shoring.
 - 3. Where rock is encountered in trenches, excavate to remove boulders and stones to provide a minimum of 9 inches clearance between the rock and the side of the pipe barrel or manhole.
 - 4. Wherever the prescribed maximum trench width is exceeded, the Contractor shall use the next higher Class or Type of bedding and haunching as shown on the Drawings for the full trench width as actually cut. The excessive trench width may be due to unstable trench walls, inadequate or improperly placed bracing and sheeting which caused sloughing, accidental over-excavation, intentional over-excavation necessitated by the size of the Contractor's tamping and compaction equipment, intentional over-excavation due to the size of the Contractor's excavation equipment, or other reasons beyond the control of the Engineer or Owner.
- D. Depth:
 - 1. The trenches shall be excavated to the required depth or elevation which allow for the placement of the pipe and bedding to the dimensions shown on the Drawings.
 - 2. Water Mains:
 - a. Depth of Trenches: Excavate trenches to provide depths as shown on the Drawings. The depth of cover shall not exceed that as shown on the Drawings by more than 2 feet, without approval of the Engineer or Owner.
 - b. Excavate trenches to provide a minimum cover not less than 3 feet. Within the right-of-way of highways, streets or roadways, excavate to place the top of the pipe a minimum of 40 inches below the nearest pavement edge or drainage ditch.
 - c. Increase the depth of cover where specifically shown on the Drawings and where necessary to avoid interference with underground utilities and obstructions.
 - d. Depth of cover shall not exceed 3 feet unless indicated on the Drawings.

3. Where rock is encountered in trenches for pipelines, excavate to the minimum depth which will provide clearance below the pipe barrel of 8 inches for pipe 21 inches in diameter and smaller and 12 inches for larger pipe, valves, and manholes/vaults. Remove boulders and stones to provide a minimum of 6 inches clearance between the rock and any part of the pipe, or accessory.
- E. Excavated Materials:
1. Excavated materials shall be placed adjacent to the work to be used for backfilling as required. Topsoil shall be carefully separated and lastly placed in its original location.
 2. Excavated material shall be placed sufficiently back from the edge of the excavation to prevent caving of the trench wall, to permit safe access along the trench and not cause any drainage problems. Excavated material shall be placed so as not to damage existing landscape features or man-made improvements.

3.2 SHEETING, BRACING, AND SHORING

- A. Sheeting, bracing, and shoring shall be performed in the following instances:
1. Where sloping of the trench wall does not adequately protect persons within the trench from slides or cave-ins.
 2. In caving ground.
 3. In wet, saturated, flowing or otherwise unstable materials. The sides of all trenches and excavations shall be adequately sheeted, braced, and shored.
 4. Where necessary to prevent damage to adjoining buildings, structures, roadways, pavement, utilities, trees or private properties which are required to remain.
 5. Where necessary to maintain the top of the trench within the available construction easement or right-of-way.
- B. In all cases, excavation protection shall strictly conform to the requirements of the Occupational Safety and Health Act of 1970, as amended.
- C. Timber: Timber for shoring, sheeting or bracing shall be sound and free of large or loose knots and in good, serviceable condition. Size and spacing shall be in accordance with OSHA regulations.
- D. Steel Sheeting and Sheet Piling: Steel sheet piling shall be the continuous interlock type. The weight, depth, and section modulus of the sheet piling shall be sufficient to restrain the loads of earth pressure and surcharge from existing foundations and live loads. Procedure for installation and bracing shall be so scheduled and coordinated with the removal of the earth that the ground under existing structures shall be protected against lateral movement at all times. The Contractor shall provide closure and sealing between sheet piling and existing facilities.
- E. Trench Shield: A trench shield or box may be used to support the trench walls. The use of a trench shield does not necessarily preclude the additional use of bracing and sheeting. When trench shields are used, care shall be taken to avoid disturbing the alignment and grade of the pipe or disrupting the haunching of the pipe as the shield is moved. When the bottom of the

trench shield extends below the top of the pipe, the trench shield shall be raised in 6-inch increments with specified backfilling occurring simultaneously. At no time shall the trench shield be “dragged” with the bottom of the shield extending below the top of the pipe or utility.

- F. Remove bracing and sheeting in units when backfill reaches the point necessary to protect the pipe and adjacent property. Leave sheeting in place when in the opinion of the Engineer it cannot be safely removed or is within 3 feet of an existing structure, utility or pipeline. Cut off any sheeting left in place at least 2 feet below the surface.

3.3 ROCK EXCAVATION

- A. Definition of Rock: Any material which cannot be excavated with conventional excavating equipment, and is removed by drilling and blasting, and occupies an original volume of at least one-half cubic yard.
- B. Blasting: Blasting is prohibited unless conditionally approved by the Owner. Contractor will comply with all applicable seismic criteria and furnish photography of before and after blasting operations. Contractor assumes all liability for his/her blasting activities. Provide licensed, experienced workmen to perform blasting. Conduct blasting operations in accordance with all existing ordinances and regulations. Protect all buildings and structures from the effects of the blast. Repair any resulting damage. If the Contractor repeatedly uses excessive blasting charges or blasts in an unsafe or improper manner, the Engineer or Owner may direct the Contractor to employ an independent blasting consultant to supervise the preparation for each blast and approve the quantity of each charge.
- C. Removal of Rock: Dispose of rock off-site that is surplus or not suitable for use as rip rap or backfill.
- D. The Contractor shall notify the Engineer or Owner prior to any blasting. Additionally, the Contractor shall notify the Engineer or Owner before any charge is set.
- E. Following review by the Engineer or Owner regarding the proximity of permanent buildings and structures to the blasting site, the Engineer or Owner may direct the Contractor to employ an independent, qualified specialty subcontractor, approved by the Engineer or Owner, to monitor the blasting by use of seismograph, identify the areas where light charges must be used, conduct pre-blast and post-blast inspections of structures, including photographs or videos, and maintain a detailed written log.

3.4 DEWATERING EXCAVATIONS

- A. The Contractor, at his/her own expense, shall provide adequate facilities for promptly removing water from all excavations. Dewater the excavation continuously to maintain a water level 2 feet below the bottom of the trench.
- B. Control drainage in the vicinity of excavation so the ground surface is properly sloped to prevent water running into the excavation.

- C. There shall be sufficient pumping equipment, in good working order, available at all times, to remove any water that accumulates in excavations. Where the utility crosses natural drainage channels, the work shall be conducted in such a manner that unnecessary damage or delays in the prosecution of the work will be prevented. Provision shall be made for the satisfactory disposal of surface water to prevent damage to public or private property.
- D. In all cases, accumulated water in the trench shall be removed before placing bedding or haunching, laying pipe, placing concrete or backfilling.
- E. Where dewatering is performed by pumping the water from a sump, crushed stone shall be used as the medium for conducting the water to the sump. Sump depth shall be at least 2 feet below the bottom of the trench. Pumping equipment shall be of sufficient quantity and/or capacity to maintain the water level in the sump 2 feet below the bottom of the trench. Pumps shall be a type such that intermittent flows can be discharged. A standby pump shall be required in the event the operating pump or pumps clog or otherwise stop operation.
- F. Dewater by use of a well point system when pumping from sumps does not lower the water level 2 feet below the trench bottom. Where soil conditions dictate, the Contractor shall construct well points cased in sand wicks. The casing, 6 to 10 inches in diameter, shall be jetted into the ground, followed by the installation of the well point, filling casing with sand, and withdrawing the casing.

3.5 TRENCH FOUNDATION AND STABILIZATION

- A. The bottom of the trench shall provide a foundation to support the pipe and its specified bedding. The trench bottom shall be graded to support the pipe and bedding uniformly throughout its length and width.
- B. Should the undisturbed material encountered at the trench bottom constitute, in the opinion of the Engineer, an unstable foundation for the pipe, the Contractor shall be required to remove such unstable material and fill the trench to the proper subgrade with crushed stone or 3,000 psi concrete as directed by the Engineer or Owner.
- C. Where trench stabilization is provided, the trench stabilization material shall be compacted to at least 90 percent of the maximum dry density, unless shown or specified otherwise.

3.6 BEDDING AND HAUNCHING

- A. Prior to placement of bedding material, the trench bottom shall be free of any water, loose rocks, boulders or large dirt clods.
- B. Bedding material shall be placed to provide uniform support along the bottom of the pipe and to place and maintain the pipe at the proper elevation. The initial layer of bedding placed to receive the pipe shall be brought to the grade and dimensions indicated on the Drawings. All bedding shall extend the full width of the trench bottom. The pipe shall be placed and brought to grade by tamping the bedding material or by removal of the excess amount of the bedding material under the pipe. Adjustment to grade line shall be made by scraping away or filling with bedding material. Wedging or blocking up of pipe shall not be permitted. Applying pressure to the top of the pipe, such as with a backhoe bucket, to lower the pipe to

the proper elevation or grade shall not be permitted. Each pipe section shall have a uniform bearing on the bedding for the length of the pipe, except immediately at the joint.

- C. At each joint, excavate bell holes of ample depth and width to permit the joint to be assembled properly and to relieve the pipe bell of any load.
- D. After the pipe section is properly placed, add the haunching material to the specified depth. The haunching material shall be shovel sliced, tamped, vigorously chinked or otherwise consolidated to provide uniform support for the pipe barrel and to fill completely the voids under the pipe, including the bell hole. Prior to placement of the haunching material, the bedding shall be clean and free of any water, loose rocks, boulders or dirt clods.
- E. Water Mains:
 - 1. Ductile Iron Pipe (DIP):
 - a. Unless otherwise shown on the Drawings or specified, bedding and haunching shall utilize earth materials and meet the requirements for Type 2, Pipe Bedding, where rock is not encountered.
 - b. In areas where rock is encountered, bedding and haunching material shall be crushed stone for Type 5. Crushed stone bedding shall extend a minimum of 6 inches below the pipe.
 - c. Where the depth of cover over the piping exceeds 15 feet, the pipe bedding shall meet the requirements of Type 4, Pipe Bedding. Where the depth of cover over the piping exceeds 18 feet, the pipe bedding shall meet the requirements of Type 5, Pipe Bedding.
 - d. Type 4 or Type 5, Pipe Bedding, called for on the Drawings, specified or ordered by the Engineer, shall meet requirements for Type 4 or Type 5, Pipe Bedding, utilizing crushed stone bedding and haunching material.
 - 2. Polyvinyl Chloride (PVC) Pipe (where approved for use by Owner):
 - a. Unless otherwise shown on the Drawings or specified, bedding and haunching shall utilize earth materials and meet the requirements for Type 2, Pipe Bedding where rock is not encountered.
 - b. In areas where rock is encountered, bedding and haunching material shall be crushed stone for Type 5, Bedding. Crushed stone bedding shall extend a minimum of 6 inches below and above the pipe.
- F. Excessive Width and Depth:
 - 1. Water Mains: If the trench is excavated to excess width, provide the next higher Type or Class of pipe bedding, but a minimum of Type 4, as detailed on the Drawings.
 - 2. If the trench is excavated to excessive depth, provide crushed stone to place the bedding at the proper elevation or grade.
 - 3. Depth of cover will not exceed 5 feet unless indicated on the plans.
- G. Compaction: Bedding and haunching materials under pipe, manholes, and accessories shall be compacted to a minimum of 90 percent of the maximum dry density, unless shown or specified otherwise.

3.7 INITIAL BACKFILL

- A. Initial backfill shall be placed to anchor the pipe, protect the pipe from damage by subsequent backfill, and ensure the uniform distribution of the loads over the top of the pipe.
- B. Place initial backfill material carefully around the pipe in uniform layers to a depth of at least 12 inches above the pipe barrel. Layer depths shall be a maximum of 6 inches for pipe 18 inches in diameter and smaller and a maximum of 12 inches for pipe larger than 18 inches in diameter.
- C. Backfill on both sides of the pipe simultaneously to prevent side pressures.
- D. Compact each layer thoroughly with suitable hand tools or tamping equipment.
- E. Initial backfill shall be compacted to a minimum 90 percent of the maximum dry density, unless shown or specified otherwise.
- F. In areas where the trench is cut into rock or where suitable backfill is unavailable, crushed stone shall be used for initial backfill up to 12 inches above the pipe barrel.

3.8 CONCRETE ENCASEMENT FOR PIPELINES

- A. Where concrete encasement is shown on the Drawings for pipelines, excavate the trench to provide a minimum of 6 inches clearance from the bell of the pipe. Lay the pipe to line and grade on concrete blocks. In lieu of bedding, haunching and initial backfill, place concrete to the full width of the trench and to a height of not less than 6 inches above the pipe bell. Do not backfill the trench for a period of at least 24 hours after concrete is placed.

3.9 FINAL BACKFILL

- A. Backfill carefully to restore the ground surface to its original condition.
- B. The top 6 inches shall be topsoil obtained as specified in “Trench Excavation” of this section.
- C. Excavated material which is unsuitable for backfilling and excess materials shall be disposed of, at no additional cost to the Owner, in a manner approved by the Engineer or Owner. Surplus soil may be distributed and spread over the site if approved by the Engineer or Owner. If such spreading is allowed, the site shall be left in a clean and slightly condition and shall not affect pre-construction drainage patterns. Surplus rock from the trenching operations shall be removed from the site.
- D. If materials excavated from the trench are not suitable for use as backfill materials, provide select backfill material conforming to the requirements of this section.
- E. After initial backfill material has been placed and compacted, backfill with final backfill material. Place backfill material in uniform layers, compacting each layer thoroughly as follows:

1. In 6-inch layers, if using light power tamping equipment, such as a “jumping jack”.
 2. In 12-inch layers, if using heavy tamping equipment, such as hammer with tamping feet.
 3. In 24-inch layers, if using a hydra-hammer.
- F. Settlement: If trench settles, refill and grade the surface to conform to the adjacent surfaces.
- G. Final backfill shall be compacted to a minimum 90 percent of the maximum dry density, unless specified otherwise.

3.10 BACKFILL UNDER ROADS AND RESIDENTIAL DRIVEWAYS

- A. Crushed stone shall be used as bedding, haunching, initial and final backfill for all pipe materials. If flowable fill is required, it shall be used as final backfill up to the top of the asphalt or concrete pavement. Steel plate shall cover the patch until the fill has cured. Once the flowable fill has cured, the required thickness can be removed, and appropriate materials can be used to repair the road.
- B. When required by the Owner or Road Department having jurisdiction; one-half of the road crossing shall be excavated, then temporary bridges consisting of steel plate shall be placed over the excavation for use by the traveling public; then the remainder of the excavation can be carried out.
- C. Paving requirements and surface restoration of pavement shall be determined by the Road Department having jurisdiction. If jurisdiction is uncertain, the Contractor shall meet the minimum requirements of the County the work is being performed in. Contractor shall comply with Section 32 10 13, Article 3.1, regarding the licensing requirements of the pavement contractor performing all pavement repairs on the project.

3.11 BACKFILL WITHIN TDOT RIGHT-OF-WAY

- A. Backfill within the TDOT right-of-way shall meet all requirements, standards, and specifications stipulated by TDOT.

3.12 BACKFILL ALONG RESTRAINED JOINT PIPE

- A. Backfill along restrained joint pipe shall be compacted to a minimum 90 percent of the maximum dry density.

3.13 DETECTION WIRE

- A. Provide detection wire as specified in Section 33 10 00, Water Mains and Accessories, Article 2.2, Paragraph A., of these Specifications.

3.14 TESTING AND INSPECTION

- A. The soils testing laboratory is responsible for the following:
1. Compaction tests in accordance with Article 1.2, above.

2. Field density tests for each 2 feet of lift, one test for each 2,000 feet of pipe installed or more frequently if ordered by the Engineer.
 3. Inspecting and testing stripped site, subgrades, and proposed fill materials.
- B. The Contractor's duties relative to testing include:
1. Notifying laboratory of conditions requiring testing.
 2. Coordinating with laboratory for field testing.
 3. Paying costs for additional testing performed beyond the scope of that required and for retesting where initial tests reveal non-conformance with specified requirements.
 4. Providing excavation as necessary for laboratory personnel to conduct tests.
- C. Inspection:
1. Earthwork operations, acceptability of excavated materials for bedding or backfill, and placing and compaction of bedding and backfill is subject to inspection by the Engineer or Owner.
 2. Foundations and shallow spread footing foundations are required to be inspected by a Geotechnical Engineer, who shall verify suitable bearing and construction.
- D. Comply with applicable codes, ordinances, rules, regulations, and laws of local, municipal, state or federal authorities having jurisdiction.

END OF SECTION

THIS PAGE INTENTIONALLY LEFT BLANK

PART 1 GENERAL

1.1 SCOPE

- A. The work to be performed under this section shall consist of removing and replacing existing pavement where such have been removed for construction of water mains, fire hydrants, and all other water appurtenances and structures.
- B. These Specifications are only the minimum requirements; actual requirements may be greater depending upon the situation. These Specifications may be adjusted by the sole discretion of the Owner to fit a particular situation not routinely encountered, or as public safety issues become apparent.

1.2 SUBMITTALS

- A. Certificates: Provide certificates stating that materials supplied comply with Specifications. Certificates shall be signed by the asphalt producer and the Contractor.

1.3 CONDITIONS

- A. Weather Limitations:
 - 1. Do not conduct paving operations when surface is wet or contains excess of moisture which would prevent uniform distribution and required penetration.
 - 2. Construct prime and tack coats and asphaltic courses only when atmospheric temperature in the shade is above 40° F, when the underlying base is dry and when weather is not rainy.
 - 3. Place base course when air temperature is above 35° F and rising.
- B. Grade Control: Establish and maintain the required lines and grades for each course during construction operations.
- C. Paving of roads shall comply with the local, municipal, state or federal authorities having jurisdiction at the site.

PART 2 PRODUCTS

2.1 MATERIALS

- A. Mineral Aggregate Base Course: Mineral aggregate base course shall conform to the requirements of the Tennessee Department of Transportation (TDOT), Bureau of Highways, Standard Specifications for Road and Bridge Construction, Section 303, Type A Base.
- B. Bituminous Plant Mix Base (Hot Mix): The base of all paved roadways shall conform to the requirements of Section 307 of the TDOT, Bureau of Highways, Standard Specifications for Road and Bridge Construction.

- C. Bituminous Sand-Gravel Binder Course: The binder course of all paved roadways shall conform to the requirements of Section 409 of the TDOT, Bureau of Highways, Standard Specifications for Road and Bridge Construction.
- D. Asphaltic Concrete Surface (Hot Mix): The surface course for all pavement shall conform to the requirements of the TDOT, Bureau of Highways, Standard Specifications for Road and Bridge Construction, Section 411, Grading “E”.
- E. Double Bituminous Surface Treatment: The surface for all pavements shall conform to the requirements of the TDOT, Bureau of Highways, Standard Specifications for Road and Bridge Construction, Section 404.
- F. Concrete: Provide concrete and reinforcing for concrete pavement or base courses in accordance with the requirements of the TDOT, Bureau of Highways, Standard Specifications for Road and Bridge Construction, Section 501.
- G. Special Surfaces: Where driveways or roadways are disturbed or damaged which are constructed of specialty type surfaces, e.g., brick or stone, these driveways and roadways shall be restored utilizing similar, if not original, materials. Where the nature of these surfaces dictate, a specialty contractor shall be used to restore the surfaces to their previous or better condition. Special surfaces shall be removed and replaced to the limits to which they were disturbed. Where a construction joint is within 12 inches of the broken surface, the surface shall be removed and replaced to the point along the construction joint.

2.2 TYPES OF PAVEMENTS

- A. General: All existing pavement removed, destroyed or damaged by construction shall be replaced with the same type and thickness of pavement as that existing prior to construction, unless otherwise directed by the Engineer or Owner. Materials, equipment, and construction methods used for paving work shall conform to the TDOT, Bureau of Highways, Standard Specifications applicable to the particular type required for replacement, repair or new pavements.
- B. Aggregate Base: Aggregate base shall be constructed in accordance with the requirements of the TDOT, Bureau of Highways, Standard Specifications for Road and Bridge Construction, Section 303, Type A Base. Material shall be mixed and placed by the stationary plant method. If the finished compacted base course depth is 6 inches or more, the course shall be constructed in 2 or more layers of approximately equal thickness.
- C. Asphalt Concrete Base, Binder, and Surface Course: Asphalt concrete base, binder, and surface course construction shall conform to the TDOT, Bureau of Highways, Standard Specifications, Section 307, for bituminous plant mix base course; Section 409, for bituminous sand-gravel binder course; and Section 411, Grading “E” for asphalt concrete surface course. The pavement mixture shall not be spread until the designated surface has been previously cleaned and prepared, is intact, compacted as specified herein, properly cured, dry, and the prime and/or tack coat has been applied. Apply and compact the asphalt concrete in maximum layer thickness by asphalt spreader equipment of design and operation approved by the Engineer. After compaction, the asphalt concrete shall be smooth and true

to established profiles and sections. Immediately correct any high, low or defective areas by cutting out the course, replacing with fresh hot mix, and immediately compacting to conform and thoroughly bond to the surrounding area.

- D. Concrete Pavement: Concrete pavement or base courses shall be replaced with concrete. The surface finish of the replaced concrete pavement shall conform to that of the existing pavement. The surface of the replaced concrete base course shall be left rough. The slab depth shall be equivalent to the existing concrete pavement or base course, but in no case less than 6 inches thick. Transverse and longitudinal joints removed from concrete pavement shall be replaced at the same locations and to the same types and dimensions as those removed. Concrete pavements or concrete base courses shall be reinforced and shall conform to the TDOT, Bureau of Highways, Standard Specifications, Section 501.
- E. Double Bituminous Surface Treatment: Double bituminous surface treatment shall be replaced with a minimum thickness of 1-inch conforming to the TDOT, Bureau of Highways, Standard Specifications, Section 404. No bituminous surface shall be installed between October 15 and April 15, and only when the air and pavement temperatures in the shade are above 60° F.
- F. Gravel Surfaces: Existing gravel road, drive, and parking area replacement shall meet the requirements of aggregate base course. This surfacing may be authorized by the Engineer as a temporary surface for paved streets until replacement of hard surfaced pavement is authorized.
- G. Temporary Measures: During the time period between pavement removal and complete replacement of permanent pavement, maintain highways, streets, and roadways by the use of steel running plates anchored to prevent movement. The backfill above the pipe shall be compacted, as specified elsewhere, up to the existing pavement surface to provide support for the steel running plates. All pavement shall be replaced within 7 calendar days of its removal.

PART 3 EXECUTION

3.1 QUALIFICATIONS

- A. All work on state, county, and city pavements (asphalt and concrete surfaces) must be performed by licensed pavement contractors, approved by and on TDOT's list of approved contractors. Work on driveways, parking areas, and other private sectors can be performed by staff employed by the general contractor.

3.2 REMOVING PAVEMENT

- A. General: Remove existing pavement as necessary for installing the pipeline and appurtenances.
- B. Marking: Before removing any pavement, mark the pavement neatly paralleling pipelines and existing streetlines. Space the marks the width of the trench.

- C. Breaking: Break asphalt pavement along the marks using pavement shearing equipment, jack hammers or other suitable tools. Break concrete pavement along the marks by scoring with a rotary saw and breaking below the score by the use of jack hammers or other suitable tools.
- D. Machine Pulling: Do not pull pavement with machines until the pavement is completely broken and separated from pavement to remain.
- E. Damage to Adjacent Pavement: Do not disturb or damage the adjacent pavement. If the adjacent pavement is disturbed or damaged, remove, and replace the damaged pavement.
- F. Damage to Traffic Signal Loops: Any pavement removal which will include removal of traffic signal loops embedded in the pavement shall be coordinated with the Traffic Engineering Department having jurisdiction over the traffic signal 5 days prior to pavement removal.
- G. Sidewalk: Remove and replace any sidewalks disturbed by construction for their full width and to the nearest undisturbed joint.
- H. Curbs: Tunnel under or remove and replace any curb disturbed by construction to the nearest undisturbed joint.

3.3 REPLACING PAVEMENT

- A. Preparation of Subgrade: During backfilling and compaction of the backfill, arrange to have the compaction tested by an independent testing laboratory. After compaction testing has been satisfactorily completed, replace all pavements, sidewalks, and curbs removed.
 - 1. The existing street pavement or surface shall be removed along the lines of the work for the allowable width specified for the trench or structure. After the installation of the sewerage or water works facilities and after the backfill has been compacted suitably, the additional width of pavement to be removed, as shown on the Drawings, shall be done immediately prior to replacing the pavement.
 - 2. Trench backfill shall be compacted for the full depth of the trench as specified in Section 31 23 33, Trench Excavation and Backfill, of these Specifications.
 - 3. Temporary trench backfill along streets and driveways shall include 6 inches of crushed stone or cherty clay as a temporary surfacing of the trenches. This temporary surface shall be maintained carefully at grade and dust-free by the Contractor until the backfill of the trench has thoroughly compacted in the opinion of the Engineer or Owner and permission is granted to replace the street pavement.
 - 4. When temporary crushed stone or chert surface is considered by the Engineer or Owner to be sufficient surface for gravel pavement, the surface shall be graded smooth and to an elevation that will make the final permanent surfacing level with the adjacent surfacing that was undisturbed.
- B. Pavement Replacement:
 - 1. Prior to replacing pavement, make a final cut in concrete pavement 12 inches back from the edge of the damaged pavement with a concrete saw. Remove asphalt pavement 12 inches back from the edge of the damaged pavement using pavement shearing equipment, jack hammers or other suitable tools.

2. Replace all street and roadway pavement as shown on the Drawings. Replace driveways, sidewalks, and curbs with the same material, to nearest existing undisturbed construction joint and to the same dimensions as those existing.
 3. If the temporary crushed stone or chert surface is to be replaced, the top 6 inches shall be removed and the crushed stone surfacing for unpaved streets or the base for the bituminous surface shall be placed.
 4. Following this preparation, the chert or crushed stone base shall be primed with a suitable bituminous material and surfaced with the proper type of bituminous surface treatment.
 5. Where the paved surface is to be replaced with asphaltic concrete pavement, concrete pavement or with a concrete base and a surface course, the temporary chert or crushed stone surface and any necessary backfill material, additional existing paving and new excavation shall be removed to the depth and width shown on the Drawings. All edges of the existing pavement shall be cut to a straight, vertical edge. Care shall be used to get a smooth joint between the old and new pavement and to produce an even surface on the completed street. Expansion joints, where applicable, shall be replaced in a manner equal to the original joint.
 6. Where driveways or roadways, constructed of specialty type surfaces, e.g., brick or stone are disturbed or damaged, these driveways and roadways shall be restored utilizing similar materials. Where the nature of these surfaces dictate, a specialty contractor shall be used to restore the surfaces to their previous or better condition. Special surfaces shall be removed and replaced to the limits to which they were disturbed. Where a construction joint is within 12 inches of the broken surface, the surface shall be removed and replaced to the nearest undisturbed construction joint.
 7. All open cut crossings of county roads to be thermally bonded per county standards.
- C. Pavement Resurfacing:
1. Certain areas to be resurfaced are specified or noted on the Drawings. Where pavement to be resurfaced has been damaged with potholes, the Contractor shall remove all existing loose pavement material and fill the hole with Bituminous Plant Mix Base, as specified, to the level of the existing pavement. After all pipeline installations are complete and existing pavement has been removed and replaced along the trench route, apply tack coat and surface course as specified.
 2. Resurfacing limits shall be perpendicular to the road centerline. The limits of resurfacing shall be 10 feet beyond the edge of the pavement replacement on the main road being resurfaced, and to the point of tangency of the pavement on the side streets.
- D. Pavement Striping: Pavement striping removed or paved over shall be replaced with the same type, dimension, and material as original unless directed otherwise by the Engineer or Owner.
- E. Traffic Signal Loops: The replacement or repair of all traffic signal loops removed or damaged during the removal and replacement of pavement shall be coordinated by the Contractor with the Traffic Engineering Department having jurisdiction over each traffic signal. The Contractor shall be responsible for payment of all fees associated with replacement or repair of traffic signal loops.

3.4 SIDEWALK AND CURB REPLACEMENT

A. Construction:

1. All concrete sidewalks and curbs shall be replaced with concrete.
2. Preformed joints shall be 1/2-inch thick, conforming to the latest edition of AASHTO M59 for sidewalks and AASHTO M123 for curbs.
3. Forms for sidewalks shall be of wood or metal, shall be straight and free from warp, and shall be of sufficient strength, when in place, to hold the concrete true to line and grade without springing or distorting.
4. Forms for curbs shall be metal and of an approved section. They shall be straight and free from distortions, showing no vertical variation greater than 1/8-inch in 10 feet and no lateral variation greater than 1/4-inch in 10 feet from the true plane surface on the vertical face of the form. Forms shall be of the full depth of the structure and constructed such to permit the inside forms to be securely fastened to the outside forms.
5. Securely hold forms in place true to the lines and grades indicated on the Drawings.
6. Wood forms may be used on sharp turns and for special sections, as approved by the Engineer or Owner. Where wooden forms are used, they shall be free from warp and shall be the nominal depth of the structure.
7. All mortar and dirt shall be removed from forms and all forms shall be thoroughly oiled or wetted before any concrete is deposited.

B. When a section is removed, the existing sidewalk or curb shall be cut to a neat line, perpendicular to both the centerline and the surface of the concrete slab. Existing concrete shall be cut along the nearest existing construction joints; if such joints do not exist, the cut shall be made at minimum distances shown on the Drawings.

C. Existing concrete sidewalks and curbs that have been cut and removed for construction purposes shall be replaced with the same width and surface as the portion removed. Sidewalks shall have a minimum uniform thickness of 4 inches. The new work shall be neatly jointed to the existing concrete so that the surface of the new work shall form an even, unbroken plane with the existing surfaces.

D. The subgrade shall be formed by excavating to a depth equal to the thickness of the concrete, plus 2 inches. Subgrade shall be of such width as to permit the proper installation and bracing of the forms. Subgrades shall be compacted by hand tamping or rolling. Soft, yielding or unstable material shall be removed and backfilled with satisfactory material. Place 2 inches of porous crushed stone under all sidewalks and curbs and compact thoroughly, then finish to a smooth, unyielding surface at proper line, grade, and cross section.

E. Joint for Curbs:

1. Joints shall be constructed as indicated on the Drawings and as specified. Construct joints true to line with their faces perpendicular to the surface of the structure and within 1/4-inch of their designated position.
2. Thoroughly spade and compact the concrete at the faces of all joints filling all voids.
3. Install expansion joint materials at the point of curve at all street returns. Install expansion joint material behind the curb at abutment to sidewalks and adjacent structures.

4. Place contraction joints every 10 feet along the length of the curbs and gutters. Form contraction joints using steel templates or division plates which conform to the cross section of the structure. Leave the templates in place until the concrete has set sufficiently to hold its shape but remove them while the forms are still in place. Contraction joint templates or plates shall not extend below the top of the steel reinforcement or they shall be notched to permit the reinforcement to be continuous through the joint. Contraction joints shall be a minimum of 1-1/2 inches deep.
- F. Expansion joints shall be required to replace any removed expansion joints or in new construction wherever shown on the Drawings. Expansion joints shall be true and even, shall present a satisfactory appearance, and shall extend to within 1/2-inch of the top of finished concrete surface.
- G. Finishing:
1. Strike off the surface with a template and finish the surface with a wood float using heavy pressure, after which, contraction joints shall be made, and the surface finished with a wood float or steel trowel.
 2. Finish the face of the curbs at the top and bottom with an approved finishing tool of the radius indicated on the Drawings.
 3. Finish edges with an approved finishing tool having a 1/4-inch radius.
 4. Provide a final broom finish by lightly combing with a stiff broom after troweling is complete.
 5. The finished surface shall not vary more than 1/8-inch in 10 feet from the established grade.
- H. Driveway and Sidewalk Ramp Openings:
1. Provide driveway openings of the widths and at the locations indicated on the Drawings and as directed by the Engineer or Owner.
 2. Provide sidewalk ramp openings as indicated on the Drawings, in conformance with the applicable regulations and as directed by the Engineer or Owner.
- I. Concrete shall be suitably protected from freezing and excessive heat. It shall be kept covered with burlap or other suitable material and kept wet until cured. Provide necessary barricades to protect the work. All damage caused by people, vehicles, animals, rain, the Contractor's operations, and the like shall be repaired by the Contractor, at no additional expense to the Owner.

3.5 MAINTENANCE

- A. The Contractor shall maintain the surfaces of roadways built and pavements replaced until the acceptance of the project. Maintenance shall include replacement, scraping, reshaping, wetting, and rerolling as necessary to prevent raveling of the road material, the preservation of reasonably smooth surfaces and the repair of damaged or unsatisfactory surfaces, to the satisfaction of the Engineer. Maintenance shall include sprinkling as may be necessary to abate dust from the gravel surfaces.

3.6 SUPERVISION AND APPROVAL

- A. Pavement restoration shall meet the requirements of the regulatory agency responsible for the pavement. Obtain agency approval of pavement restorations before requesting final payment.
- B. Obtain the Owner's or Engineer's approval of restoration of pavement, such as private roads and drives, that are not the responsibility of a regulatory agency.
- C. Complete pavement restoration as soon as possible after backfilling.
- D. Failure of Pavement: Should any pavement restoration or repairs fail or settle during the life of the Contract, including the bonded period, promptly restore or repair defects.

3.7 CLEANING

- A. The Contractor shall remove all surplus excavation materials and debris from the street surfaces and rights-of-way and shall restore street, roadway or sidewalk surfacing to its original condition.

END OF SECTION

PART 1 GENERAL

1.1 SCOPE

- A. The work covered by this section consists of furnishing all labor, equipment, and materials required to place topsoil, seed, commercial fertilizer, agricultural limestone, and mulch material, including seedbed preparation, harrowing, compacting, and other placement operations on graded earthen areas as described herein and/or shown on the Drawings. In general, seeding operations shall be conducted on all newly graded earthen areas not covered by structures, pavement or sidewalks; all cleared or grubbed areas which are to remain as finish grade surfaces; and on all existing turf areas which are disturbed by construction operations and which are to remain as finish grade surfaces. Areas disturbed by borrow activities shall also be seeded according to these Specifications.
- B. The work shall include temporary seeding operations to stabilize earthen surfaces during construction or inclement weather and to minimize stream siltation and erosion. Temporary seeding shall be performed at the times and locations as directed by the Engineer.
- C. These Specifications are only the minimum requirements; actual requirements may be greater depending upon the situation. These Specifications may be adjusted by the sole discretion of the Owner to fit a particular situation not routinely encountered, or as public safety issues become apparent.

1.2 QUALITY ASSURANCE

- A. Prior to seeding operations, the Contractor shall furnish to the Engineer labels or certified laboratory reports from an accredited commercial seed laboratory or a state seed laboratory showing the analysis and germination of the seed to be furnished. Acceptance of the seed test reports shall not relieve the Contractor of any responsibility or liability for furnishing seed meeting the requirements of this section.

PART 2 PRODUCTS

2.1 ACCEPTABLE MANUFACTURERS

- A. All materials shall conform to the requirements and standards of this section.
- B. Wood-cellulose fiber mulch shall be manufactured by Weyerhaeuser Company or Conway Corporation.

2.2 TOPSOIL

- A. Utilizing designated stockpiles or borrow areas on-site, the Contractor shall place a minimum of 4 inches of topsoil over all graded earthen areas and over any other areas to be seeded. Sources of topsoil shall be approved by the Engineer prior to disturbance. Importing topsoil from off-site sources shall be at the discretion of the Engineer and shall be

justification for additional compensation to the Contractor. A Change Order properly authorized by the Owner shall be agreed upon prior to importing off-site topsoil. No additional compensation will be allowed for spreading of topsoil.

- B. Topsoil shall be a friable loam containing a large amount of humus and shall be original surface soil of good, rich, uniform quality, free from any material such as hard clods, stiff clay, hardpan, partially disintegrated stone, pebbles larger than 1/2--inch in diameter, lime, cement, bricks, ashes, cinders, slag, concrete, bitumen or its residue, boards, sticks, chips or other undesirable material harmful or unnecessary to plant growth. Topsoil shall be reasonably free from perennial weeds and shall not contain objectionable plant material, toxic amounts of either acid or alkaline elements or vegetable debris undesirable or harmful to plant life.
- C. Topsoil shall be natural topsoil without admixture of subsoil material, and shall be classifiable as loam, silt loam, clay loam, sandy loam or a combination thereof. The pH shall range from 5.5 to 7.0. Topsoil shall contain not less than 5 percent nor more than 20 percent, by weight, of organic matter as determined by loss on ignition of oven-dried samples to 65° C.

2.3 SEED

- A. Seed shall be delivered in new bags or bags that are sound and labeled in accordance with the U.S. Department of Agriculture Federal Seed Act.
- B. All seed shall be from the last crop available at time of purchase and shall not be moldy, wet or otherwise damaged in transit or storage.
- C. Seed shall bear the growers analysis testing to 98 percent for purity and 90 percent for germination. At the discretion of the Engineer, samples of seed may be taken for verification against the grower's analysis.
- D. Replant grass removed or damaged in private residential or commercial areas using the same variety of grass and at the first appropriate season. Where sod is removed or damaged, replant such areas using sod of the same species of grass at the first appropriate season. In all areas not characterized as private, seeding requirements shall be as shown in Table 1 of this section.
- E. Species, rate of seeding, fertilization, and other requirements are shown in Table 1 of this section.

2.4 FERTILIZER AND LIMING MATERIALS

- A. Fertilizer and liming materials shall comply with applicable federal, state, and local laws concerned with their production and use.
- B. Commercial fertilizer shall be a ready mixed material equivalent to the grade or grades specified in Table 1. Container bags shall have the name and address of the Manufacturer, the brand name, net weight, and chemical composition.

- C. Agricultural limestone shall be a pulverized dolomitic limestone having a calcium carbonate content of not less than 85 percent by weight. Agricultural limestone shall be crushed so that at least 85 percent of the material will pass a No. 10 mesh screen and 50 percent will pass a No. 40 mesh screen.

2.5 MULCH MATERIAL

- A. All mulch materials shall be air dried and reasonably free of noxious weeds and weed seeds or other materials detrimental to plant growth.
- B. Mulch shall be composed of wood cellulose fiber, straw or stalks, as specified herein. Mulch shall be suitable for spreading with standard mulch blowing equipment.
- C. Straw mulch shall be partially decomposed stalks of wheat, rye, oats or other approved grain crops.
- D. Stalks shall be the partially decomposed, shredded residue of corn, cane, sorghum or other approved standing field crops.

2.6 MULCH BINDER

- A. Mulch on slopes exceeding 3 to 1 ratio shall be held in place by the use of an approved mulch binder. The mulch binder shall be non-toxic to plant life and shall be acceptable to the Engineer.
- B. Emulsified asphalt binder shall be Grade SS-1, ASTM D977. Cutback asphalt binder shall be Grade RC 70 or RC 250.

2.7 INOCULANTS FOR LEGUMES

- A. All leguminous seed shall be inoculated prior to seeding with a standard culture of nitrogen-fixing bacteria that is adapted to the particular seed involved.

2.8 WATER

- A. Water shall be clean, clear water free from any objectionable or harmful chemical qualities or organisms and shall be furnished by the Contractor.

PART 3 EXECUTION

3.1 SECURING AND PLACING TOPSOIL

- A. Topsoil shall be secured from areas from which topsoil has not been previously removed, either by erosion or mechanical methods. Topsoil shall not be removed to a depth in excess of the depth approved by the Engineer.

- B. The area or areas from which topsoil is secured shall possess such uniformity of soil depth, color, texture, drainage, and other characteristics as to offer assurance that, when removed the product will be homogeneous in nature and will conform to the requirements of these Specifications.
- C. All areas from which topsoil is to be secured, shall be cleaned of all sticks, boards, stones, cement, ashes, cinders, slag, concrete, bitumen or its residue and any other refuse which will hinder or prevent growth.
- D. In securing topsoil from a designated pit, or elsewhere, should strata or seams of material occur which do not come under the requirements for topsoil, such material shall be removed from the topsoil or if required by the Engineer, the pit shall be abandoned.
- E. Before placing or depositing topsoil upon any areas, all improvement within the area shall be completed, unless otherwise approved by the Engineer.
- F. The areas in which topsoil is to be placed or incorporated shall be prepared before securing topsoil for use.

3.2 SEEDBED PREPARATION

- A. Before fertilizing and seeding, the topsoil surfaces shall be trimmed and worked to true line from unsightly variation, bumps, ridges, and depressions, and all detrimental material, roots, and stones larger than 3 inches in any dimension shall be removed from the soil.
- B. Not earlier than 24 hours before the seed is to be sown, the soil surface to be seeded shall be thoroughly cultivated to a depth of not less than 4 inches with a weighted disc, tiller, pulvimixer or other equipment, until the surface is smooth and, in a condition acceptable to the Engineer.
- C. If the prepared surface becomes eroded as a result of rain or for any other reason, or becomes crusted before the seed is sown, the surface shall again be placed in a condition suitable for seeding.
- D. Ground preparation operations shall be performed only when the ground is in a tillable and workable condition, as determined by the Engineer.

3.3 FERTILIZATION AND LIMING

- A. Following seedbed preparation, fertilizer shall be applied to all areas to be seeded so as to achieve the application rates shown on the Drawings.
- B. Fertilizer shall be spread evenly over the seedbed and shall be lightly harrowed, raked or otherwise incorporated into the soil for a depth of 1-inch.
- C. Fertilizer need not be incorporated in the soil as specified above when mixed with seed in water and applied with power sprayer equipment. The seed shall not remain in water containing fertilizer for more than 30 minutes when a hydraulic seeder is used.

- D. Agricultural limestone shall be thoroughly mixed into the soil according to the rates shown in the Seeding Schedule shown on the Drawings. The specified rate of application of limestone may be reduced by the Engineer if pH tests indicate this to be desirable. It is the responsibility of the Contractor to obtain such tests and submit the results to the Engineer for adjustment in rates.
- E. It is the responsibility of the Contractor to make one application of a maintenance fertilizer according to the recommendations listed in the Seeding Schedule shown on the Drawings.

3.4 SEEDING

- A. Seed of the specified group shall be sown as soon as preparation of the seedbed has been completed. No seed shall be sown during high winds, nor until the surface is suitable for working and is in a proper condition. Seeding shall be performed during the dates shown on the Drawings unless otherwise approved by the Engineer. Seed mixtures may be sown together provided they are kept in a thoroughly mixed condition during the seeding operation.
- B. Seed shall be uniformly sown by any approved mechanical method suitable for the slope and size of the areas to be seeded, preferably with a broadcast type seeder, windmill hand seeder or approved mechanical power drawn seed drills. Hydro-seeding and hydro-mulching may be used on steep embankments, provided full coverage is obtained. Care shall be taken to adjust the seeder for seedings at the proper rate before seeding operations are started and to maintain their adjustment during seeding. Seed in hoppers shall be agitated to prevent segregation of the various seeds in a seeding mixture.
- C. Immediately after sowing, the seeds shall be covered and compacted to a depth of 1/8-inch to 3/4-inch by a cultipacker or suitable roller.
- D. Leguminous seeds shall be inoculated prior to seeding with an approved and compatible nitrogen-fixing inoculant in accordance with the Manufacturer's mixing instructions.

3.5 MULCHING

- A. All seeded areas shall be uniformly mulched in a continuous blanket immediately after seeding. The mulch shall be applied evenly to permit sunlight to penetrate, and the air to circulate, and at the same time shade the ground, reduce erosion, and conserve soil moisture. Approximately 45 percent of the ground shall be visible through the mulch blanket.
- B. One of the following mulches shall be spread evenly over the seeded areas at the following application rates:
 - 1. Wood Cellulose Fiber: 1,400 pounds per acre.
 - 2. Straw: 4,000 pounds per acre.
 - 3. Stalks: 4,000 pounds per acre.
 - 4. These rates may be adjusted at the discretion of the Engineer at no additional cost to the Owner, depending on the texture and condition of the mulch material and the characteristics of the seeded area.

- C. Mulch on slopes greater than 3 to 1 ratio shall be held in place using an approved mulch binder. Binder shall be thoroughly mixed and applied with the mulch. Emulsified asphalt or cutback asphalt shall be applied at the approximate rate of 5 gallons per 1,000 square feet as required to hold the mulch in place.
- D. The Contractor shall cover structures, poles, fences, and appurtenances if the mulch binder is applied in such a way that it would come in contact with or discolor the structures.
- E. Mulch and binder shall be applied by suitable blowing equipment at closely controlled application rates in a manner acceptable to the Engineer.

3.6 WATERING

- A. The Contractor shall be responsible for maintaining the proper moisture content of the soil to ensure adequate plant growth until a satisfactory stand is obtained. If necessary, watering shall be performed to maintain an adequate water content in the soil.
- B. Watering shall be accomplished by hoses, tank truck or sprinklers in such a way to prevent erosion, excessive run-off and over-watered spots.

3.7 MAINTENANCE

- A. Upon completion of seeding operations, the Contractor shall clear the area of all equipment, debris, and excess material and the premises shall be left in a neat and orderly condition.
- B. The Contractor shall maintain all seeded areas without additional payment until final acceptance of the work by the Owner, and any regrading, refertilizing, reliming, reseeding or re-mulching shall be done at Contractor's own expense. Seeding work shall be repeated on defective areas until a satisfactory uniform stand is accomplished. Damage resulting from erosion, gulleys, wash-outs or other causes shall be repaired by filling with topsoil, compacting and repeating the seeding work at Contractor's expense.

TABLE 1 – Seeding Requirements

Area	Sowing Season (Group)	Species	Rates per 1,000 Square Feet				
			Quantity % by Weight	Quantity	Limestone	Fertilizer	
Temporary Seed Flat to Rolling Terrain with Slopes Less than 3:1	January 1 – May 1 (D)	Italian Rye	33	1.5 lbs	100 lbs	20 lbs (10-10-10)	
		Korean Lespedeza	33				
		Summer Oats	34				
	May 1 – July 15 (F)	Sudan-Sorghum or Starr Millett	100	1.5 lbs	100 lbs	20 lbs (10-10-10)	
	July 15 – January 1 (E)	Balboa Rye Italian Rye	66.6 33.3	1.5 lbs	100 lbs	20 lbs (10-10-10)	
Permanent Seed Flat to Rolling Terrain with Slopes Less than 3:1	February 1 – July 1 (A)	Kentucky 31 Fescue	80	2.5 lbs	100 lbs	20 lbs (10-10-10)	
		Korean Lespedeza	15				
		English Rye	5				
		June 1 – August 15 (B)	Kentucky 31 Fescue English Rye Korean Lespedeza German Millett	55 20 15 10	2.5 lbs	100 lbs	20 lbs (10-10-10)
		April 15 – August 15 (B1)	Bermuda Grass (Hulled) Annual Lespedeza	70 30	0.6 lbs	100 lbs	20 lbs (10-10-10)
	* August 1 – December 1 (C)	Kentucky 31 Fescue English Rye White Clover	70 20 10	2.5 lbs	100 lbs	20 lbs (10-10-10)	
	February 1 – December 1 (C1)	Kentucky 31 Fescue Crown Vetch English Rye	70 25 5	1.5 lbs	100 lbs	20 lbs (10-10-10)	

Note: Omit lime application in permanent grass establishment, if it follows temporary grass established in the same area.

No seeding shall be performed during December and January unless otherwise permitted.

* Inoculate seed with EL inoculate.

END OF SECTION

THIS PAGE INTENTIONALLY LEFT BLANK

PART 1 GENERAL

1.1 SCOPE

- A. The work covered by this section includes furnishing all labor, materials, and equipment required to bore and jack casings and to properly complete pipeline construction as described herein and/or shown on the Drawings.
- B. Supply all materials and perform all work in accordance with applicable American Society for Testing and Materials (ASTM), American Water Works Association (AWWA), American National Standards Institute (ANSI) or other recognized standards. Latest revisions of all standards are applicable. If requested by the Engineer, submit evidence that Manufacturer has consistently produced products of satisfactory quality and performance over a period of at least 2 years.
- C. These Specifications are only the minimum requirements; actual requirements may be greater depending upon the situation. These Specifications may be adjusted by the sole discretion of the Owner to fit a particular situation not routinely encountered, or as public safety issues become apparent.

1.2 SUBMITTALS

- A. Submit Shop Drawings, product data, and experience in accordance with the requirements set forth by the Owner.
- B. Material Submittals: The Contractor shall provide Shop Drawings and other pertinent specifications and product data as follows:
 - 1. Shop Drawings for casing pipe showing sizes and connection details.
 - 2. Design mixes for concrete and grout.
 - 3. Casing Spacers.
- C. Experience Submittals: Boring and jacking casings are deemed to be specialty contractor work. A minimum of 5 continuous years of experience in steel casing construction is required of the casing installer. Evidence of this experience must be provided with the Shop Drawings for review by the Engineer.

1.3 STORAGE AND PROTECTION

- A. All materials shall be stored and protected in accordance with the Manufacturer's recommendations and as approved by the Engineer.

PART 2 PRODUCTS

2.1 MATERIALS AND CONSTRUCTION

A. Casing:

1. The casing shall be new and unused pipe. The casing shall be made from steel plate having a minimum yield strength of 35,000 psi. The steel plate shall also meet the chemical requirements of one of the following: ASTM A36; ASTM A139, Grade B, C, D or E; ASTM A53, Type S or Type E, Grade A or B.
2. The thicknesses of casing shown in Paragraph B., below, are minimum thicknesses. Actual thicknesses shall be determined by the casing installer, based on an evaluation of the required forces to be exerted on the casing when jacking. Any buckling of the casing due to jacking forces shall be repaired at no additional cost to the Owner.
3. The diameters of casing shown in Paragraph B., below, and shown on the Drawings are minimum. Larger casings, with the Engineer's approval, may be provided at no additional cost to the Owner, for whatever reasons the Contractor may decide, whether casing size availability, line and grade tolerances, soil conditions, etc.

B. Casing Sizes:

UNDER RAILROADS		
Pipe Diameter, inches	Casing Diameter, inches	Wall Thickness, Inches - Coated
6	14	0.25
8	18	0.25
10	20	0.281
12	22	0.312
14	24	0.344
16	30	0.406
18	30	0.406
20	32	0.438
24	36	0.469

UNDER HIGHWAYS		
Pipe Diameter, inches	Casing Diameter, inches	Wall Thickness, inches
6	12	0.25
8	16	0.25
10	16	0.25
12	18	0.25
14	22	0.25
16	24	0.25
18	30	0.312
20	30	0.312
24	36	0.375

C. Casing Spacers: Casing spacers shall meet one of the following requirements:

1. Casing spacers shall be flanged, bolt-on style with a two-section stainless steel shell lined with a PVC liner, minimum 0.09-inch thick also having a hardness of 85-90 durometer. Runners shall be attached to stainless steel risers which shall be properly welded to the shell. The height of the runners and risers shall be manufactured such that the pipe does not float within the casing.
2. Casing spacers shall be a two-section, flanged, bolt-on style constructed of heat fused PVC coated steel, minimum 14-gauge band and 10-gauge risers, with 2-inch wide glass reinforced polyester insulating skids, heavy duty PVC inner liner, minimum 0.09-inch thick having a hardness of 85-90 durometer, and all stainless steel or cadmium plated hardware.

3. Casing spacers shall be equal to Cascade Waterworks Manufacturing Company, Pipeline Seal and Insulator, Inc., or Advance Products and Systems, Inc.
- D. Carrier Pipe: Carrier pipes shall meet requirements as specified in Section 33 10 00, Water Mains and Accessories, of these Specifications.
- E. End seals will be used to seal the carrier and casing pipe ends. Seal material shall be 1/8-inch thick synthetic rubber secured with T-304 stainless steel banding straps. Seals shall be by Advance Products & Systems, Inc., Model AC.
- F. Surface Settlement Markers: Surface settlement markers within pavement areas shall be P.K. nails. Surface settlement markers within non-paved areas shall be wooden hubs.

2.2 EQUIPMENT

- A. A cutting head shall be attached to a continuous auger mounted inside the casing pipe.
- B. On casing pipe for gravity sewer over 60 feet in length, the installation equipment shall include a steering head and a grade indicator.
- C. The steering head shall be controlled manually from the bore pit. The grade indicator shall consist of a water level attached to the casing which would indicate the elevation of the front end of the casing or some other means for grade indication approved by the Engineer.

PART 3 EXECUTION

3.1 GENERAL

- A. Interpretation of soil investigation reports and data, investigating the site, and determination of the site soil conditions prior to bidding is the sole responsibility of the Contractor. Any subsurface investigation by the Bidder or Contractor must be approved by the appropriate authority having jurisdiction over the site. Rock and/or water, if encountered, shall not entitle the Contractor to additional compensation.
- B. Casing construction shall be performed so as not to interfere with, interrupt or endanger roadway surface and activity thereon, and minimize subsidence of the surface, structures, and utilities above and in the vicinity of the casing. Support the ground continuously in a manner that will prevent loss of ground and keep the perimeters and face of the casing, passages, and shafts stable. The Contractor shall be responsible for all settlement resulting from casing operations and shall repair and restore damaged property to its original or better condition at no cost to the Owner.
- C. Face Protection: The face of the excavation shall be protected from the collapse of the soil into the casing.
- D. Casing Design: Design of the bore pit and required bearing to resist jacking forces are the responsibility of the Contractor. The excavation method selected shall be compatible with expected ground conditions. The lengths of the casing shown on the Drawings are the

minimum lengths required. The length of the casing may be extended for the convenience of the Contractor, at no additional cost to the Owner. Due to restrictive right-of-way and construction easements, boring and jacking casing lengths less than the nominal 20-foot length may be necessary.

E. Highway Crossings:

1. The Contractor shall be held responsible and accountable for the coordinating and scheduling of all construction work within the highway right-of-way.
2. Work along or across the Highway Department rights-of-way shall be subject to inspection by such Highway Department.
3. All installations shall be performed to leave free flows in drainage ditches, pipes, culverts or other surface drainage facilities of the highway, street or its connections.
4. No excavated material or equipment shall be placed on the pavement or shoulders of the roadway without the express approval of the Highway Department.
5. In no instance will the Contractor be permitted to leave equipment (trucks, backhoes, etc.) on the pavement or shoulder overnight. Construction materials to be installed, which are placed on the right-of-way in advance of construction, shall be placed in such a manner as not to interfere with the safe operation of the roadway.
6. Blasting is prohibited unless conditionally approved by the Owner and the Highway authority. Contractor will comply with all applicable seismic criteria and furnish photography of before and after blasting operations. Contractor assumes all liability for his blasting activities. The Contractor shall be responsible for providing the Owner sufficient information to obtain a blasting permit in a timely manner.

F. Railroad Crossings:

1. The Contractor shall secure permission from the Railroad to schedule work so as not to interfere with the operation of the Railroad.
2. Additional insurance is required for each railroad crossing. The Contractor shall furnish the Railroad with such additional insurance as may be needed, cost of the same shall be borne by the Contractor.
3. All work on the Railroad right-of-way, including necessary support of tracks, safety of operations, and other standard and incidental operation procedures may be under the supervision of the appropriate authorized representative of the Railroad affected and any decisions of this representative pertaining to construction and/or operations shall be final and construction must be governed by such decisions.
4. If, in the opinion of the Railroad, it becomes necessary to provide flagging protection, watchmen or the performance of any other work in order to keep the tracks safe for traffic, the Contractor shall coordinate such work and shall reimburse the Railroad, in cash, for such services, in accordance with accounting procedures agreed on by the Contractor and affected Railroad before construction is started.
5. No blasting shall be permitted within the Railroad right-of-way.

3.2 GROUNDWATER CONTROL

- A. The Contractor shall control the groundwater throughout the construction of the casing.

- B. Methods of dewatering shall be at the option and responsibility of the Contractor. Maintain close observation to detect settlement or displacement of surface facilities due to dewatering. Should settlement or displacement be detected, notify the Engineer immediately and take such action as necessary to maintain safe conditions and prevent damage.
- C. When water is encountered, provide and maintain a dewatering system of sufficient capacity to remove water on a 24-hour basis keeping excavations free of water until the backfill operation is in progress. Dewatering shall be performed in such a manner that removal of soil particles is held to a minimum. Dewater into a sediment trap and comply with applicable stream pollution prevention requirements.

3.3 SAFETY

- A. Provide all necessary bracing, bulkheads, and shields to ensure complete safety to all traffic, persons, and property at all times during the work. Perform the work in such a manner as to not permanently damage the roadbed or interfere with normal traffic over it.
- B. Observe all applicable requirements of the regulations of the authorities having jurisdiction over this site. Conduct the operations in such a manner that all work will be performed below the level of the roadbed.
- C. Perform all activities in accordance with the Occupational Safety and Health Act of 1970 (PL-596), as amended, applicable regulations of the Federal Government, OSHA 29CFR 1926 and applicable criteria of ANSI A10.16-81, "Safety Requirements for Construction of Tunnel Shafts and Caissons".

3.4 SURFACE SETTLEMENT MONITORING

- A. Provide surface settlement markers, placed as specified and as directed by the Engineer. The Contractor shall place settlement markers outside of pavement area, along the centerline of the casing at 20-foot intervals and offset 10 feet each way from the centerline of the tunnel. Markers shall also be placed at each shoulder of the roadway, at each edge of pavement, at the centerline of the pavement and at 10 and 25 feet in each direction from the centerline of the casing. Tie settlement markers to benchmarks and indices sufficiently removed as not to be affected by the casing operations.
- B. Make observations of surface settlement markers, placed as required herein, at regular time intervals acceptable to the Engineer. In the event settlement or heave on any marker exceeds 1-inch, the Contractor shall immediately cease work and using a method approved by the Engineer and the authority having jurisdiction over the project site, take immediate action to restore surface elevations to that existing prior to start of casing operations.
- C. Take readings and permanently record surface elevations prior to start of dewatering operations and/or shaft excavation. The following schedule shall be used for obtaining and recording elevation readings: all settlement markers, once a week; all settlement markers within 50 feet of the casing heading, at the beginning of each day; more frequently at the Engineer's direction if settlement is identified. Make all elevation measurements to the nearest 0.01 foot.

- D. The Contractor shall cooperate fully with jurisdictional personnel. Any settlement shall be corrected by, and at the expense of, the Contractor.
- E. Promptly report any settlement and horizontal movement immediately to the Engineer and take immediate remedial action.

3.5 BORING AND JACKING

- A. Shaft:
 - 1. Conduct boring and jacking operations from a shaft excavated at one end of the section to be bored. Where conditions and accessibility are suitable, place the shaft on the downstream end of the bore.
 - 2. The shaft shall be rectangular and excavated to a width and length required for ample working space. If necessary, sheet and shore shaft properly on all sides. Shaft sheeting shall be timber or steel piling of ample strength to safely withstand all structural loadings of whatever nature due to site and soil conditions. Keep preparations dry during all operations. Perform pumping operations as necessary.
 - 3. The bottom of the shaft shall be firm and unyielding to form an adequate foundation upon which to work. In the event the shaft bottom is not stable, excavate to such additional depth as required, and place a gravel subbase or a concrete subbase if directed by the Engineer due to soil conditions.
- B. Jacking Rails and Frame:
 - 1. Set jacking rails to proper line and grade within the shaft. Secure rails in place to prevent settlement or movement during operations. The jacking rails shall cradle and hold the casing pipe on true line and grade during the progress of installing the casing.
 - 2. Place backing between the heels of jacking rails and the rear of the shaft. The backing shall be adequate to withstand all jacking forces and loads.
 - 3. The jacking frame shall be of adequate design for the magnitude of the job. Apply thrust to the end of the pipe in such a manner to impart a uniformly balanced load to the pipe barrel without damaging the joint ends of the pipe.
- C. Boring and jacking of casing pipes shall be accomplished by the dry auger boring method without jetting, sluicing or wet-boring.
- D. Auger the hole and jack the casing through the soil simultaneously.
- E. Bored installations shall have a bored-hole diameter essentially the same as the outside diameter of the casing pipe to be installed.
- F. Execute boring ahead of the casing pipe with extreme care, commensurate with the rate of casing pipe penetration. Boring may proceed slightly in advance of the penetrating pipe and shall be made in such a manner to prevent any voids in the earth around the outside perimeter of the pipe. Make all investigations and determine if the soil conditions are such as to require the use of a shield.

- G. As the casing is installed, check the horizontal and vertical alignment frequently. Make corrections prior to continuing operation. For casing pipe installations over 100 feet in length, the auger shall be removed, and the alignment and grade checked at minimum intervals of 60 feet.
- H. Any casing pipe damaged in jacking operations shall be repaired, if approved by the Engineer, or removed and replaced at Contractor's own expense.
- I. Lengths of casing pipe, as long as practical, shall be used except as restricted otherwise. Joints between casing pipe sections shall be butt joints with complete joint penetration, single groove welds, for the entire joint circumference, in accordance with American Welding Society recommended procedures. Prior to welding the joints, the Contractor shall ensure that both ends of the casing sections being welded are square.
- J. The Contractor shall prepare a contingency plan which will allow the use of a casing lubricant, such as bentonite, in the event excessive frictional forces jeopardize the successful completion of the casing installation.
- K. Once the jacking procedure has begun, it should be continued without stopping until completed, subject to weather and conditions beyond the control of the Contractor.
- L. Care shall be taken to ensure that casing pipe installed by boring and jacking method will be at the proper alignment and grade.
- M. The Contractor shall maintain and operate pumps and other necessary drainage system equipment to keep work dewatered at all times.
- N. Adequate sheeting, shoring, and bracing for embankments, operating pits, and other appurtenances shall be placed and maintained to ensure that work proceeds safely and expeditiously. Upon completion of the required work, the sheeting, shoring, and bracing shall be left in place, cut off or removed, as designated by the Engineer.
- O. Trench excavation, all classes and type of excavation, the removal of rock, muck, debris, the excavation of all working pits, and backfill requirements of Section 31 23 33, Trench Excavation and Backfill, are included under this section.
- P. All surplus material shall be removed from the right-of-way and the excavation finished flush with the surrounding ground.
- Q. Grout backfill shall be used for unused holes or abandoned pipes.
- R. Any replacement of carrier pipe in an existing casing shall be considered a new installation, subject to the applicable requirements of these Specifications.

3.6 VENTILATION AND AIR QUALITY

- A. Provide, operate, and maintain for the duration of casing project a ventilation system to meet safety and OSHA requirements.

3.7 INSTALLATION OF PIPE

- A. After construction of the casing is complete, and has been accepted by the Engineer, install the pipeline in accordance with the Drawings and Specifications.
- B. Check the alignment and grade of the casing and prepare a plan to set the pipe at proper alignment, grade, and elevation without any sags or high spots.
- C. The pipe shall be supported within the casing by use of casing spacers sized to limit radial movement to a maximum of 1-inch. Provide a minimum of 3 casing spacers per nominal length of pipe. Casing spacers shall be attached to the pipe at maximum 7-foot intervals.
- D. Close the ends of the casing with end seals.

3.8 SHEETING REMOVAL

- A. Remove sheeting used for shoring from the shaft and off the jobsite. The removal of sheeting, shoring, and bracing shall be done in such a manner as not to endanger or damage either new or existing structures, private or public properties, and also to avoid cave-ins or sliding in the banks.

END OF SECTION

PART 1 GENERAL

1.1 SCOPE

- A. This section describes products to be incorporated into the water mains and requirements for the installation and use of these items. Furnish all products and perform all labor necessary to fulfill the requirements of these Specifications.
- B. Supply all products and perform all work in accordance with applicable American Society for Testing and Material (ASTM), American Water Works Association (AWWA), American National Standards Institute (ANSI), or other recognized standards; latest revisions of all standards are applicable.
- C. These Specifications are only the minimum requirements; actual requirements may be greater depending upon the situation. These Specifications may be adjusted by the sole discretion of the Owner to fit a particular situation not routinely encountered, or as public safety issues become apparent.

1.2 QUALIFICATIONS

- A. If requested by the Engineer, submit evidence that Manufacturers have consistently produced products of satisfactory quality and performance for a period of at least 2 years.

1.3 SUBMITTALS

- A. Complete Shop Drawings and engineering data for all products shall be submitted to the Engineer a minimum of 5 working days prior to the Pre-Construction Conference.

1.4 TRANSPORTATION AND HANDLING

- A. Unloading: Furnish equipment and facilities for unloading, handling, distributing, and storing pipe, fittings, valves, and accessories. Make equipment available at all times for use in unloading. Do not drop or dump materials. Any materials dropped or dumped will be subject to rejection without additional justification. Pipe handled on skids shall not be rolled or skidded against the pipe on the ground.
- B. Handling: Handle pipe, fittings, valves, and accessories carefully to prevent shock or damage. Handle pipe by rolling on skids, forklift or front-end loader. Do not use material damaged in handling. Slings, hooks or pipe tongs shall be padded and used in such a manner as to prevent damage to the exterior coatings or internal lining of the pipe.

1.5 STORAGE AND PROTECTION

- A. Store all pipe which cannot be distributed along the route. Make arrangements for the use of suitable storage areas.

- B. Stored materials shall be kept safe from damage. The interior of all pipe, fittings, and other appurtenances shall be kept free from dirt or foreign matter at all times. Valves and hydrants shall be drained and stored in a manner that will protect them from damage by freezing.
- C. Pipe shall not be stacked higher than the limits recommended by the Manufacturer. The bottom tier shall be kept off the ground on timbers, rails or concrete. Pipe in tiers shall be alternated: bell, plain end; bell, plain end. At least 2 rows of timbers shall be placed between tiers and chocks, affixed to each other in order to prevent movement. The timbers shall be large enough to prevent contact between the pipe in adjacent tiers.
- D. Stored mechanical and push-on joint gaskets shall be placed in a cool location out of direct sunlight. Gaskets shall not come in contact with petroleum products. Gaskets shall be used on a first-in, first-out basis.
- E. Mechanical-joint bolts shall be handled and stored in such a manner that will ensure proper use with respect to types and sizes.

1.6 QUALITY ASSURANCE

- A. The Manufacturer shall provide written certification to the Engineer that all products furnished comply with all applicable requirements of these Specifications.

PART 2 PRODUCTS

2.1 DUCTILE IRON PIPE

- A. Ductile Iron Pipe (DIP) shall be used in the following cases:
 1. Where water mains 6 inches or larger are required.
 2. Any point where the water main crosses a public road.
 3. Where pipe is to be installed in a casing pipe (i.e., Bore and Jack).
- B. DIP shall be manufactured in accordance with AWWA C151. All pipe, except specials, shall be furnished in nominal lengths of 18 to 20 feet. Sizes will be as shown on the Drawings. All pipe shall have a minimum pressure rating as indicated in the following table, and corresponding minimum wall thickness, unless otherwise specified or shown on the Drawings:

Pipe Sizes (inches)	Pressure Class (psi)
4 - 12	350
14 - 18	350

- C. Pipe shall be cement lined in accordance with AWWA C104. Pipe shall be furnished with a bituminous outside coating.

- D. Fittings shall be ductile iron and shall conform to AWWA C110 or AWWA C153 with a minimum rated working pressure of 250 psi. Fittings shall be cement lined in accordance with AWWA C104 and shall be furnished with a bituminous outside coating. In lieu of cement lining and bituminous coating, fittings may be provided with a fusion bonded coating and lining meeting the requirements of AWWA C116.
- E. Joints:
1. Unless shown or specified otherwise, joints shall be push-on or restrained joint type for pipe and standard mechanical, push-on or restrained joints for fittings. Push-on and mechanical joints shall conform to AWWA C111.
 2. Restrained joints shall be manufactured restrained joint or restraining gasket joint as specified below:
 - a. Manufactured restrained joints shall be American, FLEX-RING or LOK-RING, U.S. Pipe TR FLEX or HP LOK or McWane Ductile SUPER-LOCK.
 - b. Restraining gasket joints shall be assembled with American Fast-Grip gaskets, McWane Ductile SURE STOP 350 or U.S. Pipe FIELD LOK gasket.
 - c. Retainer glands on a mechanical joint may be used as a restrained joint only where retainer glands are specifically shown on the drawings or where specifically specified.
 - d. Where retainer glands are allowed, in lieu of retainer glands specified elsewhere, the joint may be assembled with U.S. Pipe MJ FIELD LOK gasket.
 - e. No field welding for manufactured restrained joint pipe assembly will be permitted. Where field cutting of restrained joint pipe is required, the joint may be assembled with American Field Flex-Rings or U.S. Pipe TR FLEX GRIPPER Rings.
 3. Provide the appropriate gaskets for mechanical and flange joints. Gaskets for flange joints shall be made of 1/8-inch thick, cloth reinforced rubber, gaskets may be ring type or full-face type.
 4. Bolts and Nuts:
 - a. Provide the necessary bolts for connections. All bolts and nuts shall be threaded in accordance with ANSI B1.1, Coarse Thread Series, Class 2A external and 2B internal fit. All bolts and nuts shall be made in the U.S.A.
 - b. Bolts and nuts for mechanical joints shall be Tee Head Bolts and nuts of high strength low-alloy steel in accordance with ASTM A242 to the dimensions shown in AWWA C111/ANSI A21.11.
 5. Mechanical joint glands shall be ductile iron.
- F. Detection wire shall be provided over all DIP water mains.
- G. Acceptance will be on the basis of the Engineer's inspection and the Manufacturer's written certification that the pipe was manufactured and tested in accordance with the applicable standards.
- H. DIP shall be installed in all new developments.

2.2 POLYVINYL CHLORIDE (PVC) PIPE – AWWA C900

- A. AWWA C900 not permitted.

2.3 PVC PIPE – SDR TYPE

- A. At Owner’s discretion, PVC may be considered for use in the water system. All PVC pipe shall have belled ends for push-on type jointing and shall conform to ASTM D2241. The pipe shall have a Standard Dimension Ratio of 17 and shall be capable of withstanding a working pressure of 250 psi. Pipe shall be supplied in minimum lengths of 20 feet and in nominal diameters of less than 8 inches.
- B. Fittings shall be ductile iron and shall conform to AWWA C110 or AWWA C153 with a minimum rated working pressure of 250 psi. Fittings shall be cement lined in accordance with AWWA C104 and shall be furnished with a bituminous outside coating. In lieu of cement lining and bituminous coating, fittings may be provided with a fusion bonded coating and lining meeting the requirements of AWWA C116. Special adapters shall be provided as recommended by the Manufacturer to adapt the PVC pipe to mechanical jointing with cast or DIP, fittings or valves.
- C. Detection wire shall be provided over all PVC water mains.
- D. Acceptance will be on the basis of the Engineer’s inspection and the Manufacturer’s written certification that the pipe was manufactured and tested in accordance with the applicable standards, including the NSF. Additionally, each piece of pipe shall be stamped “NSF Approved”.

2.4 COPPER PIPE

- A. Pipe shall be hard drawn copper tubing, ASTM B88, Type K. Fittings 1-inch or smaller shall be compression type. Fittings 1-1/4-inch or larger shall be sweat type wrought copper, ANSI B16.22.
- B. Where required, sweat to screw adapters shall be cast bronze ANSI B16.18, wrought solder joint ANSI B16.22. Unions shall be cast bronze or bronze with solder connections. Joints shall be made with 95/5 solder for Type K pipe.

2.5 POLYETHYLENE (PE) TUBING

- A. Cross linked Polyethylene Pipe (PEX) is not permitted.

2.6 VALVES

- A. Gate Valves 16 Inches and Smaller in Diameter: Gate valves shall be resilient wedge type conforming to the requirements of AWWA C509 or AWWA C515 rated for 200 psi working pressure. Valves shall open left.
 - 1. Valves shall be provided with 2 O-ring stem seals with 1 O-ring located above and 1 O-ring below the stem collar. The area between the O-rings shall be filled with lubricant to provide lubrication to the thrust collar bearing surfaces each

- time the valve is operated. At least 1 anti-friction washer shall be utilized to further minimize operating torque. All seals between valve parts, such as body and bonnet, bonnet, and bonnet cover, shall be flat gaskets or O-rings.
2. The valve gate shall be made of cast or ductile iron having a vulcanized, synthetic rubber coating, or a seat ring attached to the disc with retaining screws. Sliding of the rubber on the seating surfaces to compress the rubber will not be allowed. The design shall be such that compression-set of the rubber shall not affect the ability of the valve to seal when pressure is applied to either side of the gate. The sealing mechanism shall provide zero leakage at the water working pressure when installed with the line flow in either direction.
 3. All internal ferrous surfaces shall be coated with epoxy to a minimum thickness of 4 mils. The epoxy shall be non-toxic, impart no taste to the water and shall conform to AWWA C550.
 4. Gate valves which are 16 inches in size shall require 48 inches depth of bury and shorter style valve boxes. Transition to deeper cut by vertically deflecting pipe at bells over 3 pipe joints each side of the valve installation.
 5. Gate valves shall be manufactured by Mueller or American Flow Control.
- B. Valves Smaller than 2 Inches: Valves shall be bronze, heavy duty, with blow-out proof stem, TPTFE seats, and stuffing box ring. Ball shall be chromium plated. Valve ends shall be threaded or compression type as appropriate. Valves shall have a minimum 200 psi working pressure for water. Valves shall be Combraco 70 series.
- C. Butterfly Valves on Larger than 12-inch Mains:
1. Butterfly valves shall be resilient seated, short body design, and shall be designed, manufactured, and tested in accordance with all requirements of AWWA C504, and as modified below. Valves shall be designed for a rated working pressure of not less than 1-1/2 times the design pressure, minimum 150 psi, Class B, AWWA C504, Section 5.2, testing requirements are modified as follows:
 - a. The leakage test shall be performed at a pressure equal to rated working pressure;
 - b. The hydrostatic test shall be performed at a pressure 2 times the rated working pressure; and
 - c. Proof of design tests shall be performed and certification of such proof of design test shall be provided to the Engineer.
 2. Valve bodies shall be ductile iron conforming to ASTM A536, Grade 65-45-12 or ASTM A 26, Grade B, cast iron. Shafts shall be ASTM A276, Type 304, stainless steel, machined and polished. Valve discs shall be ductile iron, ASTM A536, Grade 65-45-12 or ASTM A126, Grade B, cast iron. The resilient valve seat shall be located either on the valve disc or in the valve body and shall be fully field adjustable and field replaceable.
 3. Valve bodies shall be ductile iron conforming to ASTM A536, Grade 65-45-12 or ASTM A126, Grade B, cast iron. Shafts and shaft hardware shall be ASTM A564, Type 630, stainless steel, machined and polished. Valve discs shall be ductile iron, ASTM A536, Grade 65-45-12. The resilient valve seat shall be located either on the valve disc or in the valve body and shall be fully field adjustable and field replaceable.

4. Valves shall be installed with the valve shafts horizontal. Valves and actuators shall have seals on all shafts and gaskets on valve actuator covers to prevent the entry of water. Actuator mounting brackets shall be totally enclosed and shall have gasket seals.
5. Actuators:
 - a. Valves shall be equipped with traveling nut, self-locking type actuators designed, manufactured, and tested in accordance with AWWA C504. Actuators shall be capable of holding the disc in any position between full open and full closed without any movement or fluttering of the disc.
 - b. Actuators shall be furnished with fully adjustable mechanical stop-limiting devices. Actuators that utilize the sides of the actuator housing to limit disc travel are unacceptable.
 - c. Valve actuators shall be capable of withstanding a minimum of 450-foot pounds of input torque in either the open or closed position without damage.
6. Operators: Valves for buried service shall have a nut type operator and shall be equipped with a valve box and stem extension, as required.
7. Valve ends shall be mechanical joint type, except where flanged or restrained joint ends are shown.
8. Butterfly valves shall be manufactured by Mueller.

2.7 FIRE HYDRANTS

- A. All fire hydrants shall conform to the requirements of AWWA C502 for 250 psi working pressure. Hydrants shall be the compression type, closing with line pressure. The valve opening shall not be less than 5-1/4 inches for 8-inch diameter water main size and larger. The valve for 6-inch diameter water main can be 4-1/2 inches opening.
- B. In the event of a traffic accident, the hydrant barrel shall break away from the standpipe at a point above grade utilizing a “breakable flange” above the groundline which will prevent damage to the barrel and stem, preclude opening of the valve, and permit rapid and inexpensive restoration without digging or cutting off the water.
- C. The means for attaching the barrel to the standpipe shall permit facing the hydrant a minimum of 8 different directions.
- D. Hydrants shall be fully bronze mounted with all working parts of bronze. Valve seat ring shall be bronze and shall screw into a bronze retainer.
- E. All working parts, including the seat ring shall be removable through the top without disturbing the barrel of the hydrant.
- F. The operating nut shall match those on the existing hydrants. The operating threads shall be totally enclosed in an operating chamber, separated from the hydrant barrel by a rubber O-ring stem seal and lubricated by a grease or an oil reservoir.
- G. Hydrant shall be a non-freezing design and be provided with a simple, positive, and automatic drain which shall be fully closed whenever the main valve is opened.

- H. Hose and pumper connections shall be breech-locked, pinned or threaded and pinned to seal them into the hydrant barrel. Each hydrant shall have 2 (two) 2-1/2-inch hose connections and 1 (one) 4-1/2-inch pumper connection, all with NSF threads and each equipped with cap and non-kinking chain.
- I. Hydrants shall be furnished with a mechanical joint connection to the spigot of the 6-inch hydrant lead.
- J. Minimum depth of bury shall be 40 inches for all hydrants located off of a 12-inch size water main or smaller. Hydrants located off of a 16-inch size water main or larger require longer hydrant barrel to accommodate main line isolation valves 16-inch size or larger. Provide extension section where necessary for proper vertical installation and in accordance with Manufacturer's recommendations.
- K. All outside surfaces of the barrel above grade shall be painted with enamel equal to Koppers Glamortex 501 in the color Red. Exposed surfaces shall be shop painted with 1 coat of alkyd primer and 2 coats of alkyd enamel.
- L. Hydrants shall be traffic model and shall be M&H Valve 129T, Mueller Super Centurion or American Darling.

2.8 AUTOMATIC FLUSHING HYDRANT

- A. The automatic water distribution flushing system is comprised of the self-contained automatic flushing unit with dechlorination capabilities, and hand-held programmer with a 9-volt power source offering up 1 year of life under normal use.
- B. The components shall be contained within a maintenance free and non-corrosive enclosure. The self-contained unit shall be supplied with a bottom-vented base designed to direct the flow of water from the hydrant onto an exterior splash pad leading away from the unit. The unit shall contain the following major components.
 - 1. The internal control valve shall be capable of being activated by a 3.6-volt lithium power source offering up to 7 years of service under normal operating conditions.
 - 2. The control valve shall be a globe valve type design capable of passing debris up to 5/8-inch in diameter without obstructing the valve's throat.
 - 3. Internal piping shall be schedule 80 PVC and shall have a static pressure rating of 150 psi with an operating pressure of 100 psi.
- C. Automatic water distribution flushing equipment to be supplied shall be Hydro-Guard[®] Standard Unit (HG-1) as manufactured by Environmental Enhancement & Technologies.

2.9 VALVE BOXES AND EXTENSION STEMS

- A. All valves shall be equipped with valve boxes. The valve boxes shall be cast iron 2-piece screw type with drop covers. Valve boxes shall have a 5-1/4-inch inside diameter. Valve box covers shall weigh a minimum of 13 pounds. The valve boxes shall be adjustable to 6 inches up or down from the nominal required cover over the pipe. Valve boxes shall be of sufficient length that bottom flange of the lower belled portion of the box is below the valve operating

nut. Ductile or cast iron extensions shall be provided as necessary. Covers shall have “WATER VALVE” or “WATER” cast into them.

- B. All valves shall be furnished with extension stems, as necessary, to bring the operating nut to within 30 inches of the top of the valve box. Connection to the valve shall be with a wrench nut coupling and a set screw to secure the coupling to the valve’s operating nut. The coupling and square wrench nut shall be welded to the extension stem. Extension stems shall be equal to Mueller A-26441 or M&H Valve Style 3801.

2.10 RETAINER GLANDS

- A. Retainer glands for DIP shall be Megalug Series 1100, as manufactured by EBAA Iron, Uni-Flange Series 1400, as manufactured by Ford Meter Box Company or Star Pipe Products Star-Grip Series 3000.
- B. Retainer glands for PVC pipe shall be Megalug, Series 2000PV as manufactured by EBAA Iron, Inc.

2.11 RETAINER RINGS

- A. Retaining rings for PVC or DIP shall be GripRing as manufactured by Romac.

2.12 TAPPING SLEEVES AND VALVES

- A. Tapping sleeves for 10-inch and larger mains shall be ductile iron of the split-sleeve, mechanical joint type. The Contractor shall be responsible for determining the outside diameter of the pipe to be connected to prior to ordering the sleeve. Valves shall be gate valves furnished in accordance with the specifications shown above, with flanged connection to the tapping sleeve and mechanical joint connection to the branch pipe. The tapping sleeve and valve shall be supplied by the Valve Manufacturer. All sleeves and valves shall be rated for 200 psi. Tapping sleeves shall be equal to Mueller or American Flow Control. Provide spare set of MJ side gaskets and MJ end gaskets for every tapping sleeve installed.
- B. Tapping sleeves for 8-inch and smaller mains shall be stainless steel of the split-sleeve, mechanical joint type. The Contractor shall be responsible for determining the outside diameter of the pipe to be connected to prior to ordering the sleeve. Valves shall be gate valves furnished in accordance with the specifications shown above, with flanged connection to the tapping sleeve and mechanical joint connection to the branch pipe. The tapping sleeve and valve shall be supplied by the Valve Manufacturer. All sleeves and valves shall be rated for 200 psi. Tapping sleeves shall be equal to Romac “SST” or Mueller.

2.13 MISCELLANEOUS ACCESSORIES

- A. Tapping saddles for air release valves shall be nylon coated ductile iron construction. Body shall meet ASTM A395. Stainless steel shall be 304L. Tapping saddles shall be manufactured by Mueller or Ford. Tapping saddle shall meet all parts of AWWA C800 and be NSF 61 Certified.

1. Saddles installed on DIP, or for 2 inches and larger shall utilize 2 stainless steel straps to fasten around the pipe.
2. Saddled installed on PVC pipe smaller than 2 inches shall be single clamp style made of brass.

B. Dresser Couplings shall be 12 inches in length and constructed of brass.

2.14 CORPORATION COCKS AND CURB STOPS

A. Corporation cocks and curb stops shall be suitable for flared tube compression type joint and shall conform to AWWA C800 rated to 300 psi.

2.15 AIR VALVES FOR WATER SERVICE

A. Air Release Valves shall be one of the following types:

1. The air release valve shall automatically release air accumulations from the pipeline due to the action of the float. When the air valve body fills with air, the float falls freely from the orifice to allow the air to escape to the atmosphere. When all the air has been exhausted from the valve body, the float will be buoyed up to seat against the orifice and prevent water from being exhausted from the valve. The float shall be free floating within the valve body. Valve orifice size shall be as shown on the Drawings.
2. The air release valve shall automatically release air accumulations from the pipeline due to the action of the float and lever mechanism. When the air valve body fills with air, the float falls. Through the leverage mechanism, this causes the resilient seat to open the orifice and allow the air to escape to the atmosphere. When all the air has been exhausted from the valve body, the float will be buoyed up. Through the leverage mechanism, this will cause the resilient seat to close the orifice, preventing water from being exhausted from the valve. Valve orifice size shall be as shown on the Drawings.

B. Air/Vacuum Valves shall discharge large amounts of air as the pipeline fills and allow air to enter the pipeline as it drains or in the event of vacuum conditions. As air enters the valve the float shall drop from the orifice and allow the air to escape. As water rises in the valve, the float will again seal the orifice. The valve will be of such design that the float cannot blow shut at any air velocity. Valve inlet size shall be as shown on the Drawings.

C. Combination Air Valves shall combine the features of an air release valve and an air/vacuum valve and shall be of one of the following types:

1. Valve shall consist of an air/vacuum valve described in Paragraph B., above, with an air release valve described in Paragraph A., above, tapped into its body. The valve shall be of 2-piece body design with an isolation gate valve separating the 2 valves.
2. Valve shall be single body, double orifice, allowing large volumes of air to escape out the larger diameter air and vacuum orifice when filling a pipeline and closes watertight when the liquid enters the valve. During large orifice closure, the smaller diameter air release orifice will open to allow small pockets of air to escape automatically and independently of the large orifice. The large air/vacuum orifice

shall also allow large volumes of air to enter through the orifice during pipeline drainage to break the vacuum. Valve sizes shall be as shown on the Drawings.

- D. Surge check valves where shown on the Drawings or specified, provide a surge check valve on the inlet of the air/vacuum valve. The surge check valve shall be normally open, spring loaded valve consisting of a body, seat, and plug bolted to the inlet of the air/vacuum valve. The surge check valve shall operate on the interphase between the kinetic energy and relative velocity flows of air and water, allowing air to pass through but water shall close the surge check, reducing the rate of water flow by means of throttling orifices in the plug to prevent shock closure of the air/vacuum valve. The surge check orifices must be an adjustable type to suit operating conditions in the field.
- E. All air valves and accessories shall be supplied by a single Manufacturer and shall be Vent-O-Mat Series RBX with ISO 9001 rating Materials of Construction include 304 Stainless Steel barrels, tie rods, and fasteners; 316 Stainless Steel nozzles; where applicable for larger size valves fusion bonded epoxy coated ductile iron top and bottom flanges; ABS Polylac top cover; and HDPE floats.

2.16 MANHOLES AND PRECAST CONCRETE PRODUCTS

- A. Provide precast concrete products in accordance with the following:
 - 1. Precast Concrete Sections:
 - a. Precast concrete sections shall meet the requirements of ASTM C478. The minimum compressive strength of the concrete in precast sections shall be 4,000 psi. The minimum wall thickness shall be 1/12 of the inside diameter of the base, riser or the largest cone diameter.
 - b. Transition slabs which convert bases larger than 4 feet in diameter to 4-foot diameter risers shall be designed by the precast Concrete Manufacturer to carry the live and dead loads exerted on the slab.
 - c. Seal joints between precast sections by means of rubber O-ring gaskets or flexible butyl rubber sealant. Butyl rubber sealants shall meet the requirements of AASHTO M-198. Sealant shall be pre-formed type with a minimum nominal diameter of 1-inch.
 - d. Butyl rubber sealant shall be equal to Kent Seal No. 2 or Concrete Sealants CS 202.
 - 2. Brick and Mortar: Brick shall be whole and hard burned, conforming to ASTM C32, Grade MS. Mortar shall be made of 1-part Portland cement and 2-parts clean sharp sand. Cement shall be Type 1 and shall conform to ASTM C150. Sand shall meet ASTM C144.
 - 3. Iron Castings:
 - a. Cast iron manhole frames, covers, and steps shall meet the requirements of ASTM A48, Class 30, gray iron and all applicable local standards. All castings shall be tough, close grained, smooth and free from blow holes, blisters, shrinkage, strains, cracks, cold shots, and other imperfections. No casting will be accepted which weighs less than 95 percent of the design weight. Shop Drawings must indicate the design weight and provide sufficient dimensions to permit checking.
 - b. Manhole frames and covers shall say "Water" and have a 24-inch diameter clear opening and be equal to East Jordan Ironworks 1040.

- c. All frames and covers shall have machined horizontal bearing surfaces.
- 4. Plastic Steps: Manhole steps of polypropylene, molded around a steel rod, equal to products of M.A. Industries may be used.
- 5. Anchor Bolts: Concrete anchor bolts shall be used to anchor the frame to the manhole riser. Bolts shall be 5/8-inch diameter by 4-1/2-inch long.
- 6. Floor Door:
 - a. Door shall be single or double leaf type as shown on the Drawings.
 - b. The frame shall be 1/4-inch extruded aluminum alloy 6063-T6, with built-in neoprene cushion and with strap anchors bolted to the exterior. Door leaf shall be 1/4-inch aluminum diamond plate, alloy 6061-T6, reinforced with aluminum stiffeners as required. Stainless steel hinges shall be bolted to the underside and pivot on torsion bars that counterbalance the door for easy operation. The door shall open to 90 degrees and lock automatically in that position. A vinyl grip handle shall be provided to release the cover for closing. The door shall be built to withstand a live load of 300 pounds per square foot and shall be equipped with a snap lock and removable handle. Bituminous coating shall be applied to exterior of frame by the Manufacturer. The door shall also be provided with a hasp and padlock in addition to the built-in locking mechanism. Padlocks for all doors shall be keyed alike.
 - c. The floor door shall be manufactured by The Bilco Company or Washington Aluminum Company.
- 7. Where vent pipes are shown on the Drawings, vents shall be of 1-piece, welded steel construction. Vent pipes shall equal air valve size, but no less than 4 inches. The vent pipe shall be grouted into a precast hole in the vault. The discharge of the vent pipe shall be provided with a 3/16-inch PVC coated mesh screen.

2.17 HYDRANT TEES

- A. Hydrant tees shall be equal to ACIPCO A10180 or U.S. Pipe U-592.

2.18 VALVE KEYS

- A. The Contractor shall provide to the Owner 1 valve key for every 5 valves provided, but no more than 3 and not less than 1 valve key. Valve keys shall be 72 inches long with a tee handle and a 2-inch square wrench nut. Valve keys shall be furnished by the Valve Manufacturer. Valve keys shall be equal to Mueller A-24610 or ACIPCO No. 1303.

2.19 CONCRETE

- A. Concrete shall have a compressive strength of not less than 3000 psi, with not less than 5-1/2 bags of cement per cubic yard and a slump between 3 to 5 inches. For job mixed concrete, submit the concrete mix design for approval by the Engineer. Ready-mixed concrete shall be mixed and transported in accordance with ASTM C94. Reinforcing steel shall conform to the requirements of ASTM A615, Grade 60.

2.20 DETECTION WIRE

- A. Detection Wire: Magnetically detectable wire shall be installed to locate all underground pipe (PVC, DIP, and Copper). Detectable wire shall be 10-gauge Thermo High Heat in a blue polyethylene insulated jacket (10 ga. THHN). Wire shall be manufactured for and be labeled “For Direct Bury”.

PART 3 EXECUTION

3.1 EXISTING UTILITIES AND OBSTRUCTIONS

- A. The Drawings indicate utilities or obstructions that are known to exist according to the best information available to the Owner. The Contractor shall call the Tennessee One Call System, Inc. (811) as required by the Tennessee Law “Underground Utility Damage Prevention Act” (Code Section 65-31-106) and all utilities, agencies or departments that own and/or operate utilities in the vicinity of the construction work site at least 72 hours (3 business days) prior to construction to verify the location of the existing utilities.
- B. Existing Utility Location: The following steps shall be exercised to avoid interruption of existing utility service.
 - 1. Provide the required notice to the utility owners and allow them to locate their facilities according to Tennessee law. Field utility locations are valid for only 10 days after original notice. The Contractor shall ensure, at the time of any excavation that a valid utility location exists at the point of excavation.
 - 2. Expose the facility, for a distance of at least 200 feet in advance of pipeline construction, to verify its true location and grade. Repair, or have repaired, any damage to utilities resulting from locating or exposing their true location.
 - 3. Avoid utility damage and interruption by protection with means or methods recommended by the utility owner.
 - 4. Maintain a log identifying when phone calls were made, who was called, area for which utility relocation was requested, and work order number issued, if any. The Contractor shall provide the Engineer an updated copy of the log bi-weekly, or more frequently, if required.
 - 5. Where the installation of water mains within subdivisions or developments coincides with the installation of other utilities it is the responsibility of the Contractor to identify potential conflicts other utilities being installed.
- C. Conflict with Existing Utilities:
 - 1. Horizontal Conflict: Horizontal distance shall be defined as the actual horizontal separation between the edge of a utility, main or service and closest edge of the proposed water main. The horizontal distance shall be at least 3 feet between the new water main and other existing utilities (except sewer, which is 10 feet). Where utilities are installed concurrently, the horizontal distance shall be 2 feet between the outside of each trench. The Contractor must change the proposed alignment of the water main to avoid horizontal conflicts.
 - 2. Vertical Conflict: Vertical distance shall be defined as the actual vertical separation between the edge of a utility, main or service and the closest edge of the proposed water main. The vertical distance shall be at least 18 inches between the water main

and other utilities. The contractor must change the proposed alignment of the water main to avoid vertical conflicts.

- D. Electronic Locator: Have available at all times an electronic pipe locator and a magnetic locator, in good working order, to aid in locating existing pipelines or other obstructions.
- E. Water and Sewer Separation:
 - 1. Water mains should maintain a minimum 10-foot edge-to-edge separation from sewer lines, whether gravity or pressure. If the main cannot be installed in the prescribed easement or right-of-way and provide the 10-foot separation, the separation may be reduced, provided the bottom of the water main is a minimum of 18 inches above the top of the sewer.
 - 2. The water main, when installed below the sewer, shall be encased in concrete with a minimum 6-inch concrete depth to the first joint in each direction. Where water mains cross the sewer, the pipe joint adjacent to the pipe crossing the sewer shall be cut to provide maximum separation of the pipe joints from the sewer.
 - 3. No water main shall pass through, or come in contact with, any part of a sanitary sewer manhole.
- F. Stream Crossings and Wet Weather Conveyances: All water mains crossing streams and wet weather conveyances shall be DIP.

3.2 CONSTRUCTION ALONG HIGHWAYS, STREETS, AND ROADWAYS

- A. Install pipelines and appurtenances along highways, streets, and roadways in accordance with the applicable regulations of, and permits issued by, the Tennessee Department of Transportation (TDOT) and the county with reference to construction operations, safety, traffic control, road maintenance, and repair.
- B. All water mains under roads shall be DIP.
- C. Traffic Control:
 - 1. The Contractor shall provide, erect, and maintain all necessary barricades, suitable and sufficient lights, and other traffic control devices; provide qualified flagmen where necessary to direct traffic; take all necessary precautions for the protection of the work and the safety of the public.
 - 2. Construction traffic control devices and their installation shall be in accordance with the current Manual on Uniform Traffic Control Devices for Streets and Highways.
 - 3. Placement and removal of construction traffic control devices shall be coordinated with TDOT or with the Department with jurisdictional authority a minimum of 48 hours in advance of the activity.
 - 4. Placement of construction traffic control devices shall be scheduled ahead of associated construction activities. Construction time in street right-of-way shall be conducted to minimize the length of time traffic is disrupted. Construction traffic control devices shall be removed immediately following their useful purpose. Traffic control devices used intermittently, such as “Flagmen Ahead”, shall be removed and replaced when needed.
 - 5. Existing traffic control devices within the construction work zone shall be protected from damage. Traffic control devices requiring temporary relocation shall be

located as near as possible to their original vertical and horizontal locations. Original locations shall be measured from reference points and recorded in a log prior to relocation. Temporary locations shall provide the same visibility to affected traffic as the original location. Relocated traffic control devices shall be reinstalled in their original locations as soon as practical following construction.

6. Construction traffic control devices shall be maintained in good repair and shall be clean and visible to affected traffic for daytime and nighttime operation. Traffic control devices affected by the construction work zone shall be inspected daily.
7. Construction warning signs shall be black legend on an orange background. Regulatory signs shall be black legend on a white background. Construction sign panels shall meet the minimum reflective requirements of TDOT. Sign panels shall be of durable materials capable of maintaining their color, reflective character, and legibility during the period of construction.
8. Channelization devices shall be positioned preceding an obstruction at a taper length as required by the current Manual on Uniform Traffic Control Devices for Streets and Highways, as appropriate for the speed limit at that location. Channelization devices shall be patrolled to ensure that they are maintained in the proper position throughout their period of use.

D. Construction Operations:

1. Perform all work along highways, streets, and roadways to minimize interference with traffic.
2. Stripping: Where the pipeline is laid along road right-of-way, strip and stockpile all sod, topsoil, and other material suitable for right-of-way restoration.
3. Trenching, Laying, and Backfilling: Do not open the trench any further ahead of pipe laying operations than is necessary. Backfill and remove excess material immediately behind laying operations. Complete excavation and backfill for any portion of the trench in the same day.
4. Shaping: Reshape damaged slopes, side ditches, and ditch lines immediately after completing backfilling operations. Replace topsoil, sod, and any other materials removed from shoulders.
5. Construction operations shall be limited to 400 feet along areas, including clean-up and utility exploration.

E. Excavated Materials: Do not place excavated material along highways, streets, and roadways in a manner which obstructs traffic. Sweep all scattered excavated material off of the pavement in a timely manner.

F. Drainage Structures: Keep all side ditches, culverts, cross drains, and other drainage structures clear of excavated material. Care shall be taken to provide positive drainage to avoid ponding or concentration of run-off.

G. Landscaping Features shall include, but are not necessarily limited to fences, property corners, cultivated trees and shrubbery, manmade improvements, subdivision, and other signs within the right-of-way and easement. The Contractor shall take extreme care in moving landscape features and promptly reestablishing these features.

- H. Maintaining Highways, Streets, Roadways, and Driveways:
1. Maintain streets, highways, roadways, and driveways in suitable condition for movement of traffic until completion and final acceptance of the work.
 2. During the time period between pavement removal and completing permanent pavement replacement, maintain highways, streets, and roadways by the use of steel running plates. Running plate edges shall have asphalt placed around their periphery to minimize vehicular impact. The backfill above the pipe shall be compacted as specified elsewhere up to the existing pavement surface to provide support for the steel running plates.
 3. Furnish a road grader or front-end loader for maintaining highways, streets, and roadways. The grader or front-end loader shall be available at all times.
 4. Immediately repair all driveways that are cut or damaged. Maintain them in a suitable condition for use until completion and final acceptance of the work.

3.3 PIPE DISTRIBUTION

- A. Pipe shall be distributed and placed in such a manner that will not interfere with traffic.
- B. No pipe shall be strung further along the route than 500 feet beyond the area in which the Contractor is actually working without written permission from the Owner. Owner reserves the right to reduce this distance to a maximum distance of 200 feet in residential and commercial areas based on the effects of the distribution to the adjacent property owners.
- C. No street or roadway may be closed for unloading of pipe without first obtaining permission from the proper authorities. The Contractor shall furnish and maintain proper warning signs and obstruction lights for the protection of traffic along highways, streets, and roadways upon which pipe is distributed.
- D. No distributed pipe shall be placed inside drainage ditches.
- E. Distributed pipe shall be placed as far as possible from the roadway pavement, but no closer than 5 feet from the roadway pavement, as measured edge-to-edge.

3.4 LOCATION AND GRADE

- A. The Drawings show the alignment of the water main and the location of valves, hydrants, and other appurtenances.
- B. Construction Staking:
1. The baselines for locating the principal components of the work and a benchmark adjacent to the work are shown on the Drawings. Baselines shall be defined as the line to which the location of the water main is referenced, i.e., edge of pavement, road centerline, property line, right-of-way or survey line. The Contractor shall be responsible for performing all survey work required for constructing the water main, including the establishment of baselines and any detail surveys needed for construction. This work shall include the staking out of permanent and temporary easements to ensure that the Contractor is not deviating from the designated easements.

2. The level of detail of survey required shall be that which the correct location of the water main can be established for construction and verified by the Engineer. Where the location of components of the water main, e.g., tunnels and fittings, are not dimensioned, the establishment on the location of these components shall be based upon scaling these locations from the Drawings with relation to readily identifiable landmarks, e.g., survey reference points, power poles, manholes, etc.
- C. Reference Points:
1. The Contractor shall take all precautions necessary, which includes, but is not necessarily limited to, installing reference points, in order to protect and preserve the centerline or baseline established by the Engineer.
 2. Reference points shall be placed, at or no more than 3 feet, from the outside of the construction easement or right-of-way. The location of the reference points shall be recorded in a log with a copy provided to the Engineer for use, prior to verifying reference point locations. Distances between reference points and the manhole centerlines shall be accurately measured to 0.01 foot.
 3. The Contractor shall give the Engineer reasonable notice that reference points are set. The reference point locations must be verified by the Engineer prior to commencing clearing and grubbing operations.
- D. After the Contractor locates and marks the water main centerline or baseline, the Contractor shall perform clearing and grubbing.
- E. Construction shall begin at a connection location and proceed without interruption. Multiple construction sites shall not be permitted without written authorization from the Engineer for each site.
- F. The Contractor shall be responsible for any damage done to reference points, baselines, centerlines, and temporary benchmarks, and shall be responsible for the cost of reestablishment of reference points, baselines, centerlines, and temporary benchmarks as a result of the operations.

3.5 LAYING AND JOINTING PIPE AND ACCESSORIES

- A. Lay all pipe and fittings to accurately conform to the lines and grades established by the Engineer.
- B. Pipe Installation:
1. Proper implements, tools, and facilities shall be provided for the safe performance of the work. All pipe, fittings, valves, and hydrants shall be lowered carefully into the trench by means of slings, ropes or other suitable tools or equipment in such a manner as to prevent damage to water main materials and protective coatings and linings. Under no circumstances shall water main materials be dropped or dumped into the trench.
 2. All pipe, fittings, valves, hydrants, and other appurtenances shall be examined carefully for damage and other defects immediately before installation. Defective materials shall be marked and held for inspection by the Engineer, who may prescribe corrective repairs or reject the materials.

3. All lumps, blisters, and excess coating shall be removed from the socket and plain ends of each pipe, and the outside of the plain end and the inside of the bell shall be wiped clean and dry and free from dirt, sand, grit or any foreign materials before the pipe is laid. No pipe containing dirt shall be laid.
4. Foreign material shall be prevented from entering the pipe while it is being placed in the trench. No debris, tools, clothing or other materials shall be placed in the pipe at any time.
5. As each length of pipe is placed in the trench, the joint shall be assembled, and the pipe brought to correct line and grade. The pipe shall be secured in place with approved backfill material.
6. It is not mandatory to lay pipe with the bells facing the direction in which work is progressing.
7. Applying pressure to the top of the pipe, such as with a backhoe bucket, to lower the pipe to the proper elevation or grade, shall not be permitted.
8. Provide detection wire for all water mains (including DIP and Copper). The wire shall have a minimum cover of 12 inches and be laid approximately 12 inches above the pipe. Tracer wire shall be connected together with a brass curney, then taped each direction an additional 3 inches. Wires in valve boxes shall be protected inside a 3/4-inch PVC pipe, leaving at least 12 inches of wire hanging out of the top of the pipe as shown in the Details. All wire must be tested for location prior to acceptance.

C. Alignment and Gradient:

1. Lay pipe straight in alignment and gradient or follow true curves as nearly as practicable. Do not deflect any joint more than the maximum deflection recommended by the Manufacturer.
2. Maintain a transit, level, and accessories on the job to lay out angles and ensure that deflection allowances are not exceeded.

D. Expediting of Work: Excavate, lay the pipe, and backfill as closely together as possible. Do not leave unjointed pipe in the trench overnight. Backfill and compact the trench as soon as possible after laying and jointing is completed. Cover the exposed end of the installed pipe each day at the close of work and at all other times when work is not in progress. If necessary, to backfill over the end of an uncompleted pipe or accessory, close the end with a suitable plug, either push-on, mechanical joint, restrained joint or as approved by the Engineer. Clean-up shall be maintained no more than 500 feet behind pipe installation and shall be brought up to the construction area at the end of each day.

E. Joint Assembly:

1. Push-on, mechanical, flange and restrained type joints shall be assembled in accordance with the Manufacturer's recommendations.
2. The Contractor shall inspect each pipe joint within 1,000 feet on either side of main line valves to ensure 100 percent seating of the pipe spigot, except as noted otherwise.
3. Each restrained joint shall be inspected by the Contractor to ensure that it has been "homed" 100 percent.
4. The Contractor shall internally inspect each pipe joint to ensure proper assembly for pipe 24 inches in diameter and larger after the pipe has been brought to final alignment.

5. DIP installed in roadways and as a carrier pipe inside a casing pipe shall utilize manufactured restrained joint gaskets. Restraining gasket joints shall be assembled with American Fast-Grip gaskets or U.S. Pipe FIELD LOK gasket.
- F. Cutting Pipe: Cut DIP using an abrasive wheel saw. Cut PVC pipe using a suitable saw; remove all burrs and smooth the end before jointing. The Contractor shall cut the pipe and bevel the end, as necessary, to provide the correct length of pipe necessary for installing the fittings, valves, accessories, and closure pieces in the correct location. Only push-on or mechanical joint pipe shall be cut.
- G. Valve and Fitting Installation:
1. Prior to installation, valves shall be inspected for direction of opening, number of turns to open, freedom of operation, tightness of pressure-containing bolting and test plugs, cleanliness of valve ports and especially seating surfaces, handling damage, and cracks. Defective valves shall be corrected or held for inspection by the Engineer. Valves shall be closed before being installed.
 2. Valves, fittings, plugs, and caps shall be set and joined to the pipe in the manner specified in this section for cleaning, laying, and joining pipe, except that 12-inch and larger valves shall be provided with special support, such as treated timbers, crushed stone, concrete pads or a sufficiently tamped trench bottom so that the pipe will not be required to support the weight of the valve. Valves shall be installed in the closed position.
 3. A valve box shall be provided on each underground valve. They shall be carefully set, centered exactly over the operating nut, and truly plumbed. The valve box shall not transmit shock or stress to the valve and shall accommodate the tracer wire and protective tubing as shown on the Details. The bottom flange of the lower belled portion of the box shall be placed below the valve operating nut. This flange shall be set on brick, so arranged that the weight of the valve box and superimposed loads will bear on the base and not on the valve or pipe. Extension stems shall be installed where depth of bury places the operating nut in excess of 30 inches beneath finished grade so as to set the top of the operating nut 30 inches below finished grade. The valve box cover shall be flush with the surface of the finished area or such other level as directed by the Engineer.
 4. In no case shall valves be used to bring misaligned pipe into alignment during installation. Pipe shall be supported in such a manner as to prevent stress on the valve.
 5. Gate and butterfly valves installed as a part of a branch or "Tee" shall be installed within 24 inches of the fitting and thrust restraints shall be used.
 6. Gate and butterfly valves shall not be installed under pavement.
- H. Hydrant Installation:
1. Prior to installation, inspect all hydrants for direction of opening, nozzle threading, operating nut and cap nut dimensions, tightness of pressure-containing bolting, cleanliness of inlet elbow, handling damage, and cracks. Defective hydrants shall be corrected or held for inspection by the Engineer.
 2. All hydrants shall stand plumb and shall have their nozzles parallel with or at right angles to the roadway, with pumper nozzle facing the roadway, except that hydrants having 2 hose nozzles 90 degrees apart shall be set with each nozzle facing the roadway at an angle of 45 degrees.

3. Hydrants shall be set to the established grade, with the centerline of the lowest nozzle at least 12 inches above the ground or as directed by the Engineer.
4. Each hydrant shall be connected to the main with a 6-inch branch controlled by an independent 6-inch valve. When a hydrant is set in soil that is pervious, drainage shall be provided at the base of the hydrant by placing coarse gravel or crushed stone mixed with coarse sand from the bottom of the trench to at least 6 inches above the drain port opening in the hydrant to a distance of 12 inches around the elbow.
5. When a hydrant is set in clay or other impervious soil, a drainage pit 2- x 2- x 2-feet shall be excavated below each hydrant and filled with coarse gravel or crushed stone mixed with coarse sand under and around the elbow of the hydrant and to a level of 6 inches above the drain port.
6. Hydrants shall be located as shown on the Drawings or as directed by the Engineer. In the case of hydrants that are intended to fail at the groundline joint upon vehicle impact, specific care must be taken to provide adequate soil resistance to avoid transmitting shock moment to the lower barrel and inlet connection. In loose or poor load bearing soil, this may be accomplished by pouring a concrete collar approximately 6 inches thick to a diameter of 24 inches at or near the groundline around the hydrant barrel.
7. Hydrant shall be installed with anchor couplings connecting the hydrant, valve, and main line tee as shown on Standard Details. In cases where anchor couplings are too short for placement of the hydrant and valve, DIP with retainer glands may be used at the discretion of the Owner.

I. Air Valve Vaults:

1. Construct the vault or manhole as detailed on the Drawings.
2. Air release valves and manholes shall be installed on water lines at all high points as shown on the Drawings.
3. Manholes shall be constructed such that their walls are plumb.
4. The frame shall be attached to the manhole barrel by means of 4 (four) 5/8-inch x 4-1/2-inch anchor bolts and shall be set in a bed of mastic so as to constitute a watertight seal between the barrel and the frame.

J. Automatic Flushing Hydrants:

1. Construct the Flushing Hydrants as detailed on the Drawings.
2. Bedding shall consist of a 4-inch lift of non-compacted sand or similar bedding material before installation of the unit.
3. Backfill the area around the automatic flushing hydrant with select materials in 6-inch lifts, keeping the flushing unit level during the filling process.

3.6 CONNECTIONS TO WATER MAINS

- A. Make connections to existing pipelines with tapping sleeves and valves, unless specifically shown otherwise on the Drawings.
- B. Location: Before laying pipe, locate the points of connection to existing water mains and uncover as necessary for the Engineer to confirm the nature of the connection to be made.

- C. Interruption of Services: Make connections to existing water mains only when system operations permit. Operate existing valves only with the specific authorization and direct supervision of the Owner. Connections involving the insertion of new tees, valves, etc., will adhere to the requirements of AWWA C651 Section 4.11 for Controlled Pipe Shutdowns. Comply with applicable criteria for removal of dirt, mud, excess water, etc., before cutting and accessing existing pipe; line flushing; disinfection; and pipe shutdown duration.
- D. Tapping Saddles and Tapping Sleeves:
 1. Holes in the new pipe shall be machine cut, either in the field or at the factory. No torch cutting of holes shall be permitted.
 2. Prior to attaching the saddle or sleeve, the pipe shall be thoroughly cleaned, utilizing a brush and rag, as required.
 3. Before performing field machine cut, the watertightness of the saddle or sleeve assembly shall be pressure tested. The interior of the assembly shall be filled with water. An air compressor shall be attached, which will induce a test pressure as specified in this section. No leakage shall be permitted for a period of 5 minutes.
 4. After attaching the saddle or sleeve to an existing main, but prior to making the tap, the interior of the assembly shall be disinfected. All surfaces to be exposed to potable water shall be swabbed or sprayed with a 1 percent hypochlorite solution.
- E. Connections Using Solid Sleeves: Where connections are shown on the Drawings using solid sleeves, the Contractor shall furnish materials and labor necessary to make the connection to the existing pipeline.
- F. Connections Using Couplings: Where connections are shown on the Drawings using couplings, the Contractor shall furnish materials and labor necessary to make the connection to the existing pipeline, including all necessary cutting, plugging, and backfill.

3.7 THRUST RESTRAINT

- A. Provide restraint at all points where hydraulic thrust may develop.
- B. Retainer Glands: Provide retainer glands where shown on the Drawings and on all fittings and valves 12 inches and larger. Retainer glands shall be installed in accordance with the Manufacturer's recommendations, particularly, the required torque of the set screws. The Contractor shall furnish a torque wrench to verify the torque on all set screws which do not have inherent torque indicators.
- C. Grip Rings: Provide grip rings where shown, and on all fittings and valves below 12 inches. Grip Rings shall be installed in accordance with the Manufacturer's recommendations.
- D. Harnessing:
 1. Provide harness rods only where specifically shown on the Drawings or directed by the Engineer.
 2. Harness rods ("All-Thread") shall be manufactured in accordance with ASTM A36 and shall have an allowable tensile stress of no less than 22,000 psi. Harness rods shall be hot-dip galvanized or field coated with bitumastic before backfilling.
 3. Where possible, harness rods shall be installed through the mechanical joint bolt holes. Where it is not possible, provide 90-degree bend eye bolts.

4. Eye bolts shall be of the same diameter as specified in AWWA C111 for that pipe size. The eye shall be welded closed. Where eye bolts are used in conjunction with harness rods, an appropriate size washer shall be utilized with a nut on each end of the harness rod. Eye bolts shall be of the same material and coating as the harness rods.
- E. Concrete Blocking:
1. Provide concrete blocking for all bends, tees, valves, and other points where thrust may develop, except where other exclusive means of thrust restraint are specifically shown on the Drawings.
 2. Concrete shall be as specified in this section.
 3. Form and pour concrete blocking at fittings as shown on the Drawings and as directed by the Engineer. Pour blocking against undisturbed earth. Increase dimensions when required by over excavation.

3.8 INSPECTION AND TESTING

- A. Pressure and Leakage Test: Testing will not be allowed to begin without the expressed approval of the Engineer. All other utility or site construction must be complete prior to testing.
1. All sections of the water main and service lines subject to internal pressure shall be pressure tested in accordance with AWWA C600. A section of main will be considered ready for testing after completion of all thrust restraint and backfilling.
 2. Each segment of water main between main valves shall be tested individually.
 3. Test Preparation:
 - a. For water mains less than 24 inches in diameter, flush sections thoroughly at flow velocities, greater than 2-1/2 feet per second, adequate to remove debris from pipe and valve seats. For water mains 24 inches in diameter and larger, the main shall be carefully swept clean, and mopped if directed by the Engineer. Partially open valves to allow the water to flush the valve seat.
 - b. Partially operate valves and hydrants to clean-out seats.
 - c. Provide temporary blocking, bulkheads, flanges, and plugs as necessary, to assure all new pipe, valves, and appurtenances will be pressure tested.
 - d. Before applying test pressure, air shall be completely expelled from the pipeline and all appurtenances. Insert corporation cocks at highpoints to expel air as main is filled with water as necessary to supplement automatic air valves. Corporation stops shall be constructed as detailed on the Drawings with a meter box.
 - e. Fill pipeline slowly with water. Provide a suitable pump with an accurate water meter to pump the line to the specified pressure.
 - f. The differential pressure across a valve or hydrant shall equal the maximum possible, but not exceed the rated working pressure. Where necessary, provide temporary backpressure to meet the differential pressure restrictions.
 - g. Valves shall not be operated in either the opening or closing direction at differential pressures above the rated pressure.

4. Test Pressure: Test the pipeline at 200 psi measured at the lowest point for at least 2 hours. Maintain the test pressure within 5 psi of the specified test pressure for the test duration. Should the pressure drop more than 5 psi at any time during the test period, the pressure shall be restored to the specified test pressure. The source of the pressure drop shall be identified and repaired. Provide an accurate pressure gauge with graduation not greater than 2 psi. Pressure testing must be performed in the presence of the Inspector.
5. Leakage:
 - a. Leakage shall be defined as the sum of the quantity of water that must be pumped into the test section, to maintain pressure within 5 psi of the specified test pressure for the test duration plus water required to return line to test pressure at the end of the test. Leakage shall be the total cumulative amount measured on a water meter.
 - b. Owner assumes no responsibility for leakage occurring through existing valves.
6. Test Results: No test section shall be accepted if the leakage exceeds the limits determined by the following formula:

$$L = \frac{SD(P)^{1/2}}{148,000}$$

Where:

L	=	allowable leakage, in gallons per hour
S	=	length of pipe tested, in feet
D	=	nominal diameter of the pipe, in inches
P	=	average test pressure during the leakage test, in pounds per square inch (gauge)

As determined under Section 5 of AWWA C600.

If the water main section being tested contains lengths of various pipe diameters, the allowable leakage shall be the sum of the computed leakage for each diameter. The leakage test shall be repeated until the test section is accepted. All visible leaks shall be repaired regardless of leakage test results.

7. Completion: After a pipeline section has been accepted, relieve test pressure. Record type, size, and location of all outlets on Record Drawings.
- B. Inspection: Inspection of construction shall be performed by the Owner's Resident Inspector. All mains and appurtenances will be inspected prior to backfilling. If any joints, pipe or other workmanship materials are found to be defective, they shall be removed and replaced by the Contractor. The Contractor shall schedule work around the Inspector's 40-hour workweek. Any required overtime for the Inspector shall be paid by the Contractor.

3.9 DISINFECTING PIPELINE

- A. After successfully pressure testing each pipeline section, disinfect in accordance with AWWA C651 for the continuous-feed method and these Specifications.

- B. Specialty Contractor: Disinfection shall be performed by an approved specialty contractor. Before disinfection is performed, the Contractor shall submit a written procedure for approval before being permitted to proceed with the disinfection. This plan shall also include the steps to be taken for the neutralization of the chlorinated water.
- C. Chlorination:
 1. Apply chlorine solution to achieve a concentration of at least 25 milligrams per liter free chlorine in new line. Retain chlorinated water for 24 hours.
 2. Chlorine concentration shall be recorded at every outlet along the line at the beginning and end of the 24-hour period.
 3. After 24 hours, all samples of water shall contain at least 10 milligrams per liter free chlorine. Rechlorinate if required results are not obtained on all samples.
- D. Disposal of Chlorinated Water: Reduce chlorine residual of disinfection water to less than 1 milligram per liter if discharged directly to a body of water or to less than 2 milligrams per liter if discharged onto the ground prior to disposal. Treat water with sulfur dioxide or other reducing chemicals to neutralize chlorine residual. Flush all lines until residual is equal to existing system.
- E. Bacteriological Testing: After final flushing and before the water main is placed in service, Owner will collect samples from the line and have tested for bacteriological quality in accordance with the rules of the Tennessee Department of Environment and Conservation (TDEC). The bacteriological samples shall be analyzed for both coliform and non-coliform growth. Two (2) or more successive sets of samples, taken at 24-hour intervals, shall indicate bacteriologically satisfactory water and the results shall be submitted to TDEC. Rechlorinate lines until required results are obtained.

3.10 PROTECTION AND RESTORATION OF WORK AREA

- A. General: Return all items and all areas disturbed, directly or indirectly by work under these Specifications, to their original condition or better, as quickly as possible after work is started.
 1. The Contractor shall plan, coordinate, and prosecute the work such that disruption to personal property and business is held to a practical minimum.
 2. All construction areas abutting lawns and yards of residential or commercial property shall be restored promptly. Backfilling of underground facilities, ditches, and disturbed areas shall be accomplished on a daily basis as work is completed. Finishing, dressing, and grassing shall be accomplished immediately thereafter, as a continuous operation within each area being constructed and with emphasis placed on completing each individual yard or business frontage. Care shall be taken to provide positive drainage to avoid ponding or concentration of run-off.
 3. Handwork, including raking and smoothing, shall be required to ensure that the removal of roots, sticks, rocks, and other debris is removed in order to provide a neat and pleasing appearance.
 4. TDOT's Engineer shall be authorized to stop all work by the Contractor when restoration and clean-up are unsatisfactory and to require appropriate remedial measures.

- B. Man-Made Improvements: Protect, or remove and replace with the Engineer's approval, all fences, walkways, mailboxes, pipelines, drain culverts, power and telephone lines, cables, property pins, and other improvements that may be encountered in the work.
- C. Cultivated Growth: Do not disturb cultivated trees or shrubbery unless approved by the Engineer. Any such trees or shrubbery which must be removed shall be heeled in and replanted under the direction of an experienced nurseryman.
- D. Cutting of Trees: Do not cut trees for the performance of the work except as absolutely necessary. Protect trees that remain in the vicinity of the work from damage from equipment. Do not store spoil from excavation against the trunks. Remove excavated material stored over the root system of trees within 30 days to allow proper natural watering of the root system. Repair any damaged tree over 3 inches in diameter, not to be removed, under the direction of an experienced nurseryman. All trees and brush that require removal shall be promptly and completely removed from the work area and disposed of by the Contractor. No stumps, wood piles or trash piles will be permitted on the work site.
- E. Disposal of Rubbish: Dispose of all materials cleared and grubbed during the construction of the project in accordance with the applicable codes and rules of the appropriate county, state, and federal regulatory agencies.
- F. Swamps and Other Wetlands:
 - 1. The Contractor shall not construct permanent roadbeds, berms, drainage structures or any other structures which alter the original topographic features within the easement.
 - 2. All temporary construction or alterations to the original topography will incorporate measures to prevent erosion into the surrounding swamp or wetland. All areas within the easement shall be returned to their original topographic condition as soon as possible after work is completed in the area. All materials of construction and other non-native materials shall be disposed by the Contractor.
 - 3. The Contractor shall provide temporary culverts or other drainage structures, as necessary, to permit the free migration of water between portions of a swamp, wetland or stream which may be temporarily divided by construction.
 - 4. The Contractor shall not spread, discharge or dump any fuel oil, gasoline, pesticide or any other pollutant to adjacent swamps or wetlands.
 - 5. The conditions of the individual Aquatic Resource Alteration Permit (ARAP) or Storm Water Pollution Prevention Plan (SWPPP) shall govern if there are any conflicts between these Specifications and project specific permits.

3.11 ABANDONING EXISTING WATER MAINS

- A. General: Abandon in place all existing water main segments indicated on the Drawings to be abandoned or retired. Perform abandonment after the new water main has been placed in service and all water main services have been changed over to the new main. Salvage for the Owner any and all existing fire hydrants, valve boxes, valve markers, and other materials indicated on the Drawings or located on water mains abandoned.

- B. Capping and Plugging: Disconnect by sawing or cutting and removing a segment of existing pipe where cutting and capping or plugging is shown on the Drawings or directed by the Engineer. Provide a watertight pipe cap or plug and concrete blocking for restraint to seal off existing mains indicated to remain in service. Seal ends of existing mains to be abandoned with a pipe cap or plug or with a masonry plug and minimum 6-inch cover of concrete on all sides around the end of the pipe. The Contractor shall be responsible for uncovering and verifying the size and material of the existing main to be capped or plugged.
- C. Salvaging Materials: Salvage existing fire hydrants, valve boxes, valve markers, and other materials as indicated on the Drawings and deliver salvaged items in good condition to Owner's storage yard; coordinate delivery and placement of salvaged materials in advance.
- D. Blow-Off Piping: Remove existing blow-off piping, located on segments of water mains to be abandoned, to a minimum of 2 feet below finished grade. Seal the end of remaining piping as specified in Paragraph B., above. Blow-off piping removed becomes the property of the Contractor.
- E. Pavement Removal and Replacement: Perform any necessary pavement removal and replacement in accordance with the details on the Drawings and the specifications of the Highway Department.

END OF SECTION

THIS PAGE INTENTIONALLY LEFT BLANK

PART 1 GENERAL

1.1 SCOPE

- A. The work covered by this section includes furnishing all materials and equipment, providing all required labor, installing water service connections, and all appurtenant work according to these Specifications and/or to the Water Connection Details as shown schematically on the Drawings.
- B. Water meters are to be furnished by the Owner and installed by the Contractor.
- C. These Specifications are only the minimum requirements; actual requirements may be greater depending upon the situation. These Specifications may be adjusted by the sole discretion of the Owner to fit a particular situation not routinely encountered, or as public safety issues become apparent.

1.2 LOCATIONS

- A. Locations shall be directed by the Engineer along the route of the water mains.

1.3 SERVICE COMPATIBILITY

- A. It is the intent of these Specifications the water service connections shall duplicate those presently being provided by the Owner to be compatible with their service maintenance procedures.

1.4 QUALITY CONTROL

- A. All materials installed under this section shall have the approval of the National Sanitation Foundation (NSF) for water services.

1.5 SUBMITTALS

- A. The Contractor shall provide Shop Drawings, engineering data, and product data to the Engineer for review.

PART 2 PRODUCTS

2.1 MATERIALS AND CONSTRUCTION

- A. Service Line:
 - 1. Copper Tubing: Tubing shall be 1-inch minimum size conforming to ASTM B88, Type K. Fittings shall be brass with compression connection inlets and outlets, ANSI B16.26. Where required, adapters shall be brass ANSI B16.18. Unions shall be cast bronze. Joints shall be compression type. All fittings shall be of bronze construction with compression type connection.

2. Cross linked Polyethylene Pipe (PEX) is not permitted.
 3. Detection wire shall be provided over all service lines.
 4. Polyvinyl Chloride (PVC) Casing Pipe: Casing pipe for long side services shall be minimum 3 inches, Schedule 80 PVC (HDPE acceptable).
- B. Meter Box:
1. Plastic meter boxes shall be provided by the Owner and installed by the Contractor.
 2. Meter box shall be fitted with cast iron cover and reader lid, with “water meter” cast in the top.
- C. Services and Accessories:
1. Corporation Cocks and Curb Stops shall be suitable for flared tube compression type joint and shall conform to AWWA C800 rated to 300 psi. Corporation cocks shall be Ford.
 2. Service Clamps:
 - a. Clamp body shall be of epoxy coated ductile iron and meet all requirements of AWWA C800.
 - b. The strap shall be Ford.
 - c. Service clamps shall be Ford.
 3. Meter Yolk shall be of provided by the Owner and installed by the Contractor.
- D. Connections to Water Mains:
1. Connections to all water mains shall be made using a full body service clamp for PVC or double strap service clamp for ductile iron pipe (DIP).
 2. Pressure ratings shall be 200 psi.
- E. Pressure Regulators where required shall be furnished and maintained by the property owner or the Developer. The regulator shall be installed on the discharge side of the water meter in a separate box or inside the building it serves.
- F. Detection Wire: See Section 33 10 00, Water Mains and Accessories, of these Specifications.

PART 3 EXECUTION

3.1 INSTALLATION

- A. Water Service Connections:
1. Water service connections shall be installed to the properties adjacent to the water transmission mains both to the same side of the roadway (Short Side Service) and to the opposite side of the roadway (Long Side Service) as directed by the Engineer.
 2. Water service connections installed under roadway shall be pulled through a minimum 3-inch casing pipe. Casings shall be installed in an open trench or through a bored hole approximately equal in diameter to the external diameter of the casing. Minimum cover under roadway shall be 40 inches and shall extend 3 feet beyond the edge of pavement or curb. At other locations, minimum cover shall be 2 feet.

3. Installation shall conform to the Details for water service connections appearing schematically on the Drawings. Contractor shall provide any and all appurtenant work required to provide the intended water service connections.
 4. Double service lines shall be 1-inch service line on both long and short side connections. Single service lines shall be 1-inch service line on both long and short side connections. Exceptions may be authorized by the Owner on a case-by-case basis. Service line material shall be at the discretion of the Owner.
- B. Permanent Water Services:
1. Each new service line shall be tapped into the main through a corporation stop, utilizing a service clamp, as detailed on the Drawings. A new service line shall be provided to the meter as shown on the Drawings.
 2. A corporation cock shall be provided in the water main for each service line.
 3. A curb stop shall be provided at each existing or future water meter location.
 4. A service line, sized to match the existing line unless directed otherwise by the Engineer, shall be provided between the corporation cock and curb stop.
 5. Permanent water service meters shall be located at the right-of-way or permanent utility easement limits.
- C. Temporary Water Services: Temporary services shall consist of relocating an existing water meter to just outside the construction limits to clear proposed grading by the Contractor. Temporary services shall include connecting the relocated meter to the existing or new water main as appropriate by means of a new service line and any additional depth service line installation required to clear proposed grading work.
- D. Relocation of Service Lines:
1. Relocate the existing meter to the new right-of-way or permanent utility easement limits and reconnect to the house service. Existing meters already located at the new right-of-way limits will not need relocating.
 2. Before disconnecting the existing meter, the existing corporation in the main shall be closed. All existing meters and meter boxes shall be removed, if not already located at the right-of-way, reinstalled, and reconnected as indicated on the Drawings.
 3. Existing service lines shall be field-located by the Contractor. The Contractor shall be responsible for locating existing water meters, relocating the meters and meter boxes as necessary, and determining the existing size service line to reconnect the meters to the new water mains. All service lines installed under existing pavement, including streets, driveways, and sidewalks, shall be installed by boring.
 4. The Contractor shall be prepared to make emergency repairs to the water system, if necessary, due to damage by others working in the area. In conjunction with this requirement, the Contractor shall furnish and have available at all times, a tapping machine, for the purpose of making temporary water service taps or emergency repairs to damaged water services.
- E. Transfer of Service: Immediately before connecting to the relocated or existing meter, all service lines shall be flushed to remove any foreign matter. Any special fittings required to reconnect the existing meter to the new copper service line, or the existing private service line, shall be provided by the Contractor. To minimize out of service time, the Contractor

shall determine the connections to be made and have all the required pipe and fittings on hand before shutting off the existing service. After completing the connection, the new corporation stop shall be opened, and all visible leaks shall be repaired.

- F. Magnetically detectable wire shall be installed to locate all underground pipe (PVC, DIP, and Copper). See Section 33 10 00, Water Mains and Accessories, of these Specifications.

END OF SECTION

Standard Detail Drawings

Water

STD-G-01	Silt Fence Detail
STD-G-02	Concrete Encasement Detail
STD-G-03	Concrete Replacement Detail
STD-G-04	Asphalt Replacement Detail
STD-G-05	Stream Crossing Detail
STD-G-06	Road Bore Detail
STD-G-07	Trench Terminology Detail
STD-G-08	Pressure Pipe Bedding and Haunching Details
STD-W-01	Typical Blocking Detail
STD-W-02	Gate Valve Installation Detail
STD-W-03	Butterfly Valve Installation Detail
STD-W-04	Fire Hydrant Assembly Detail
STD-W-05	Typical Automatic Air Release Valve Assembly Detail
STD-W-06	Water Main Blow-Off Detail Large Dia. Mains
STD-W-07	Water Service and Meter Connection Details
STD-W-08	Double Tap Assemblies Detail
STD-W-09	Water Main Termination Detail

USE MIN. OF 18 POSTS
PER 100 FT. OF LENGTH

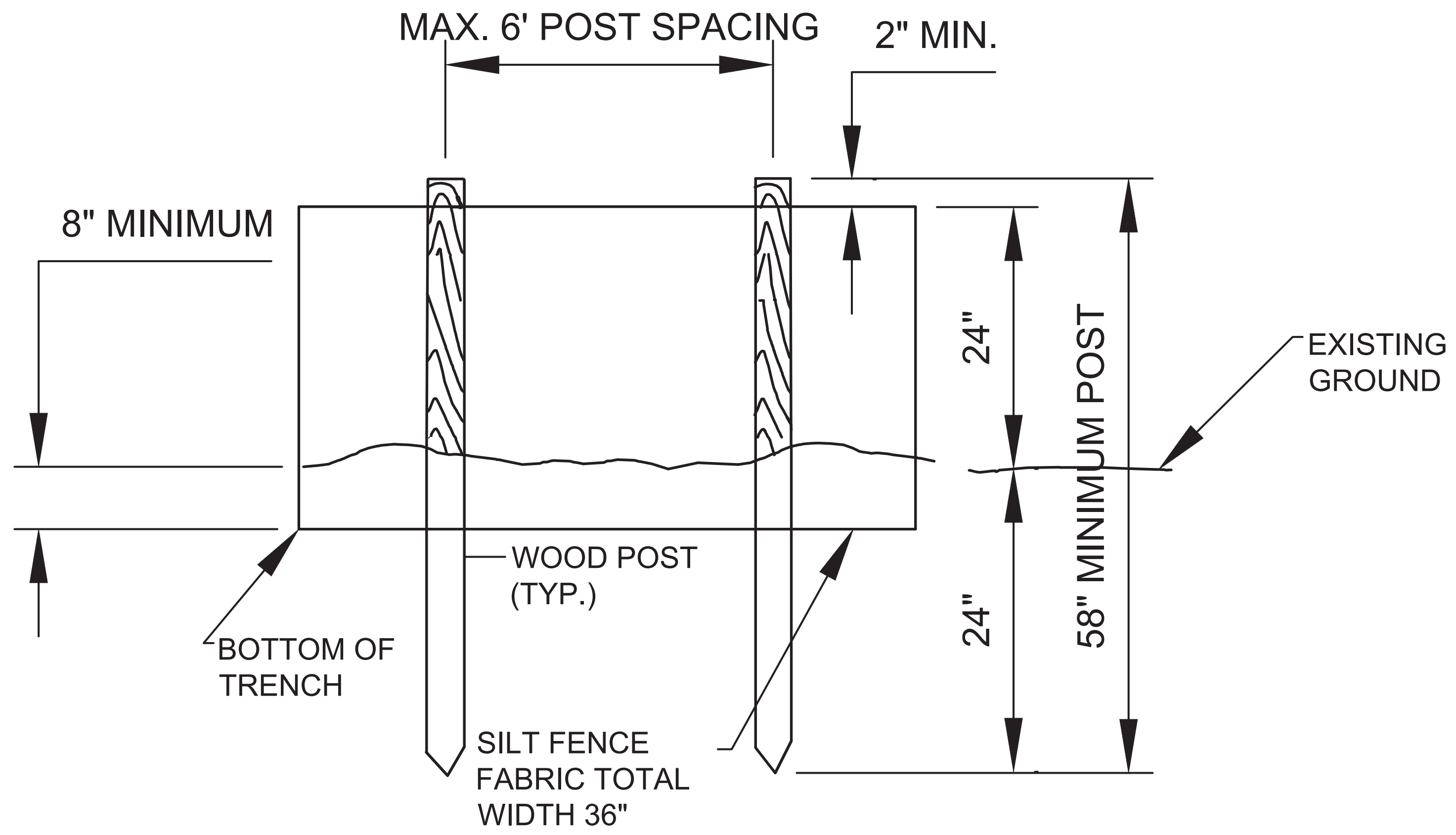

ELEVATION VIEW

MIN. 2.25" (NOMINAL) X 2.25" (NOMINAL)
- (1.75" ACTUAL X 1.75" ACTUAL) (3.06 SQ.
IN.) HARDWOOD POST (OAK OR HICKORY) OR
MIN. 1.25 LB./FT. STEEL POST (STD. "T" OR
"U" SECTION) - LENGTH 58"

TIEBACK BETWEEN FENCE POST AND
ANCHOR STAKE TO BE NO. 8 (0.25")
HOLLOW BRAIDED POLYPROPYLENE
ROPE WITH MINIMUM TENSILE
STRENGTH OF 1,200 POUNDS

POSITION POST/FABRIC
ASSEMBLY AT VERTICAL
TO A MAX. 5° FROM
THE VERTICAL (ANGLED
TOWARD FLOW)

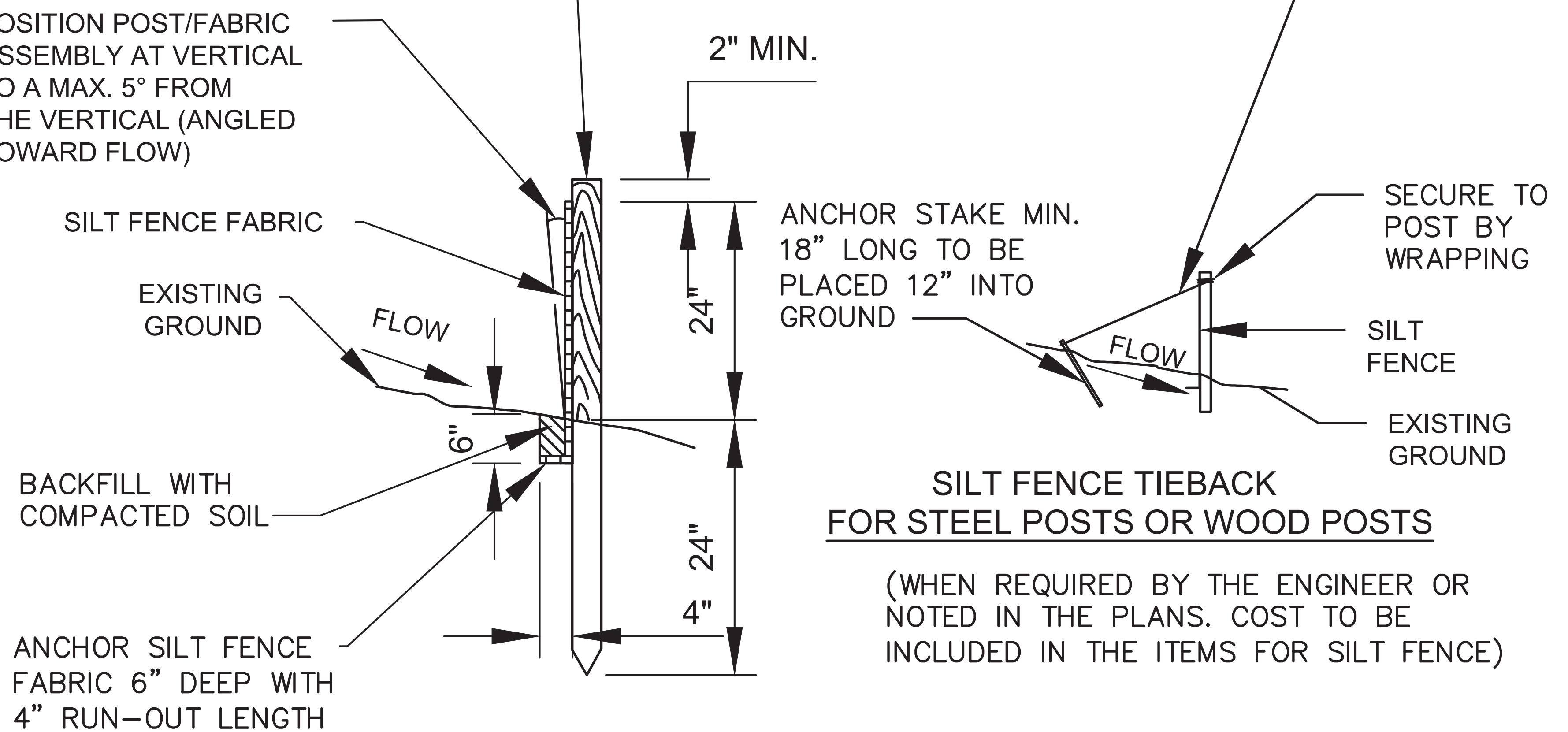

SECTIONAL VIEW

SILT FENCE DETAIL

NTS

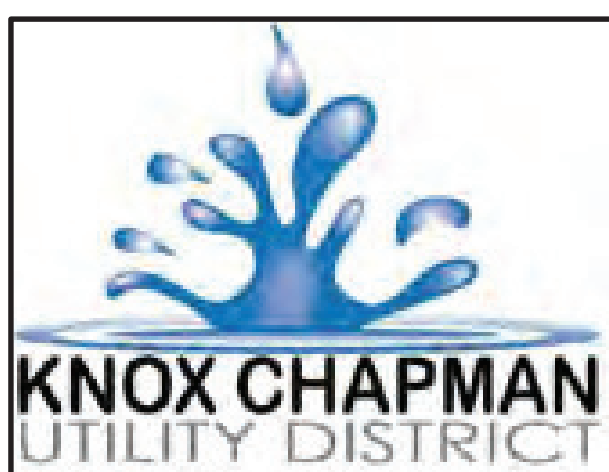

KNOX CHAPMAN UTILITY DISTRICT
WATER & SEWER

STANDARD DETAILS
SEWER

DATE: JULY 2022

SCALE: N.T.S.

STD-G-01

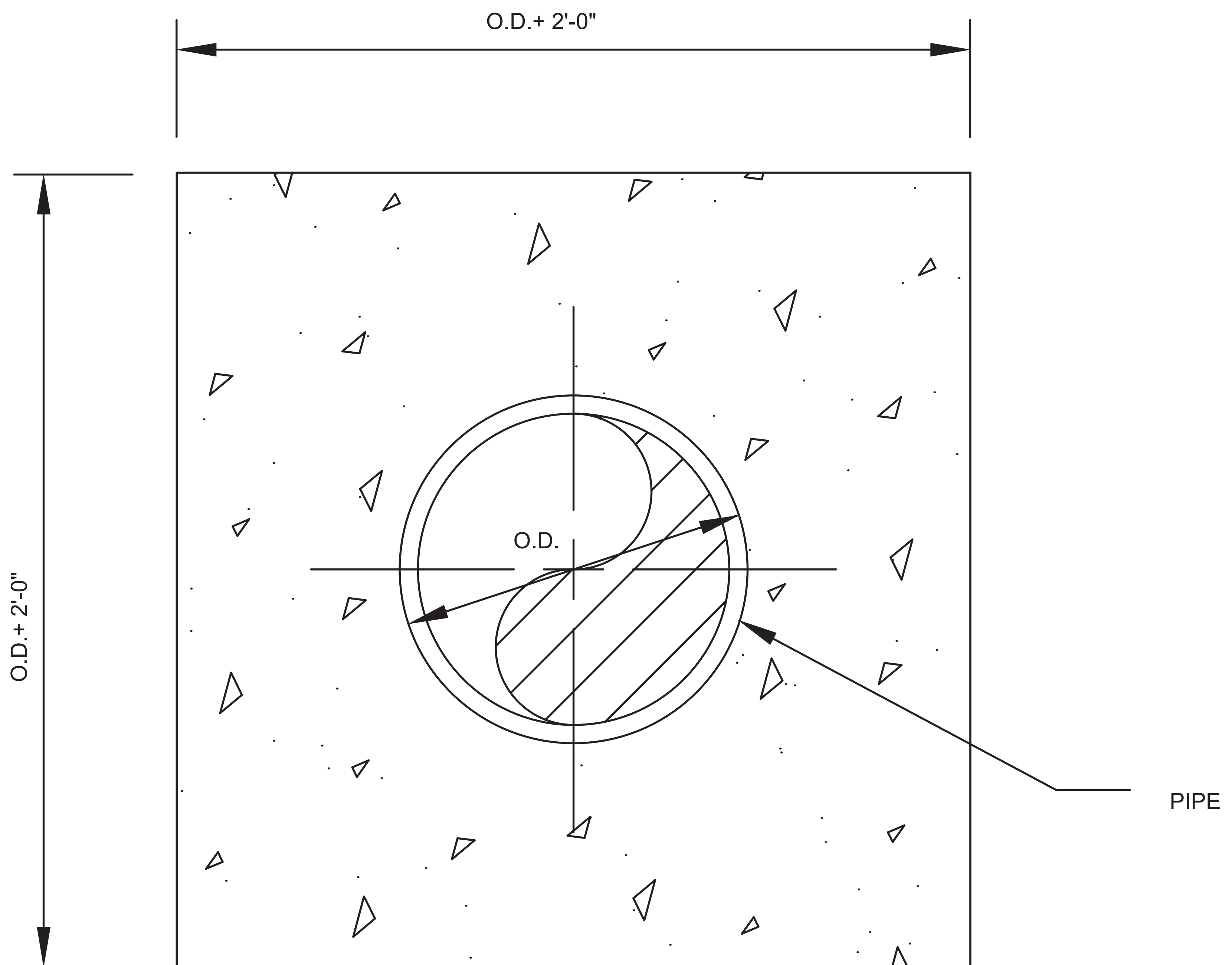

CONCRETE ENCASEMENT
DETAIL

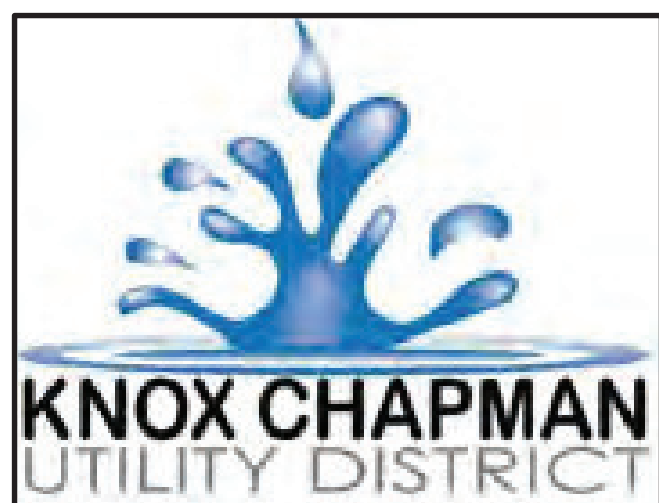

KNOX CHAPMAN UTILITY DISTRICT
WATER & SEWER

STANDARD DETAILS
WATER

DATE: JULY 2022

SCALE: N.T.S.

STD-G-02

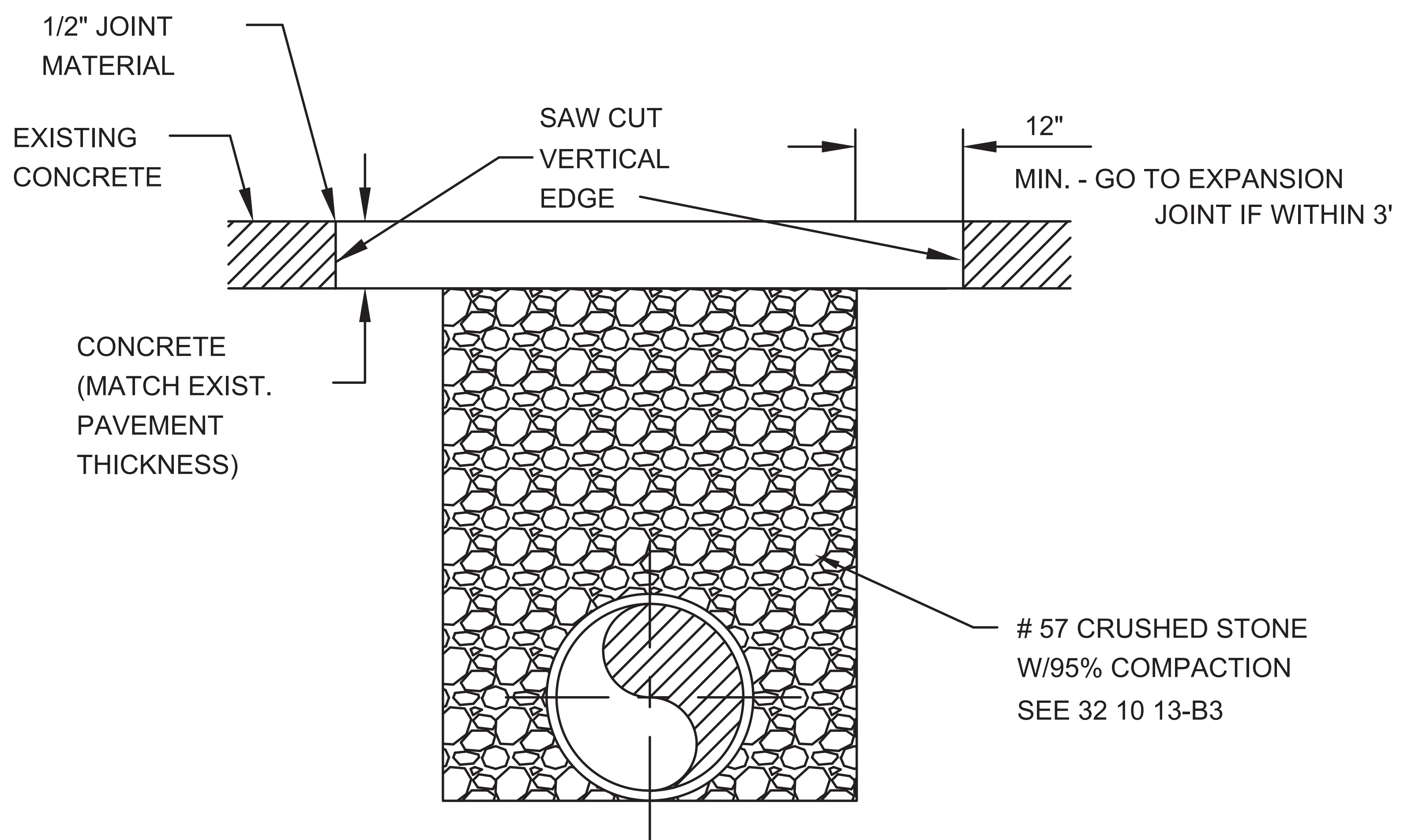

CONCRETE REPLACEMENT DETAIL

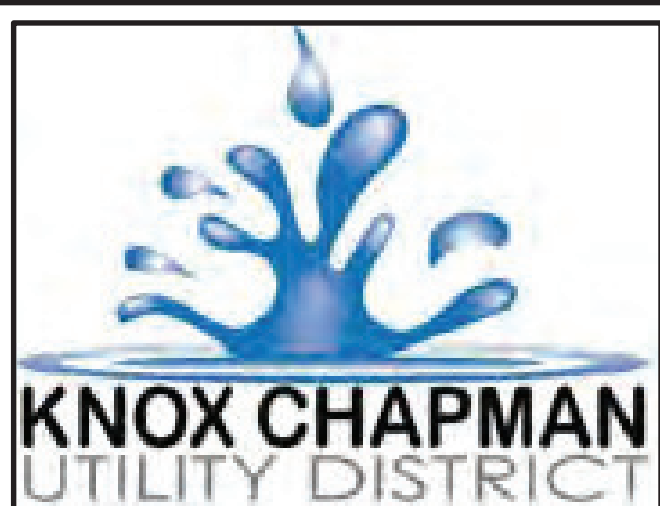

KNOX CHAPMAN UTILITY DISTRICT
WATER & SEWER

STANDARD DETAILS
WATER

DATE: JULY 2022

SCALE: N.T.S.

STD-G-03

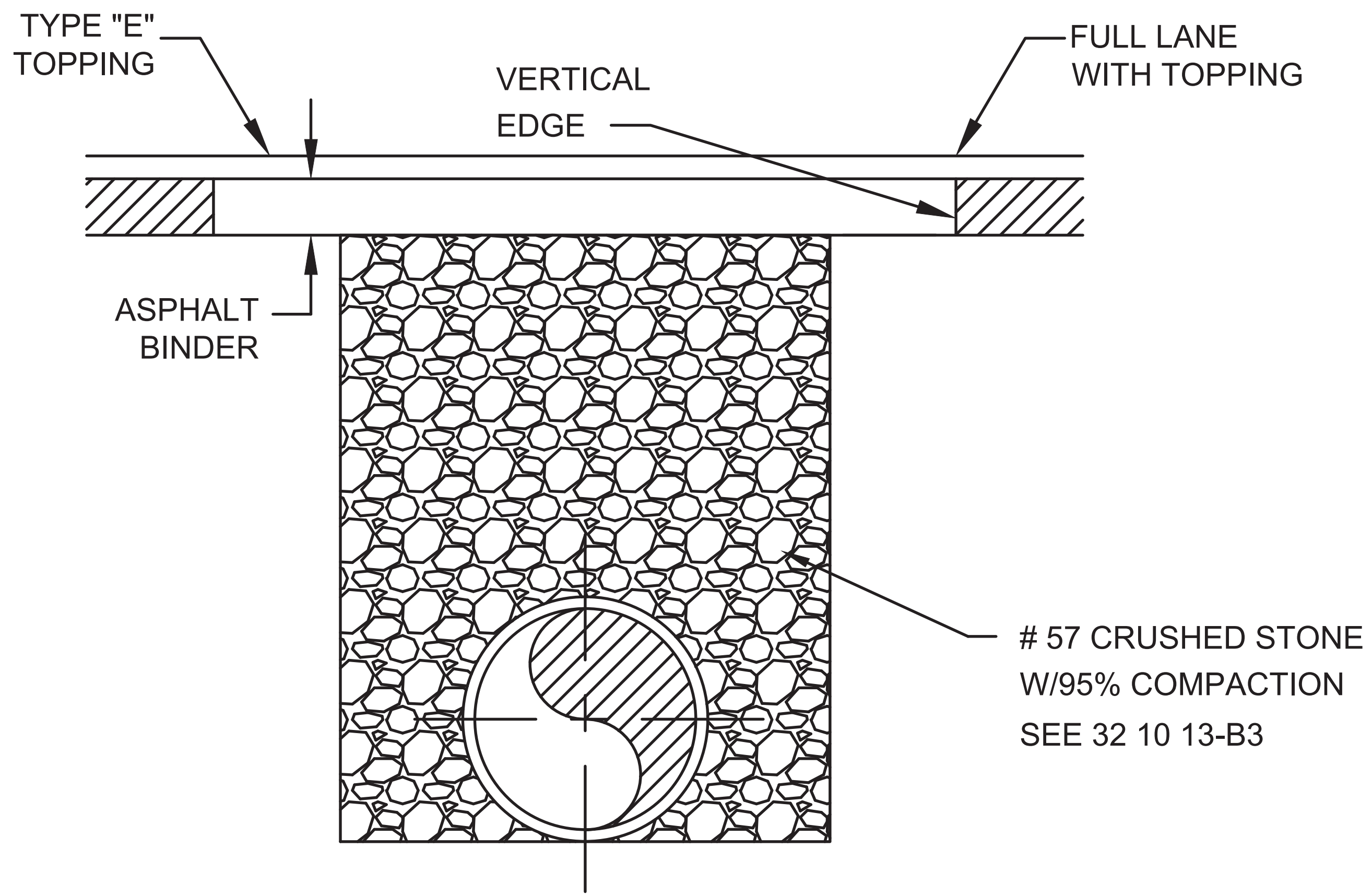

FULL LANE REPAVEMENT

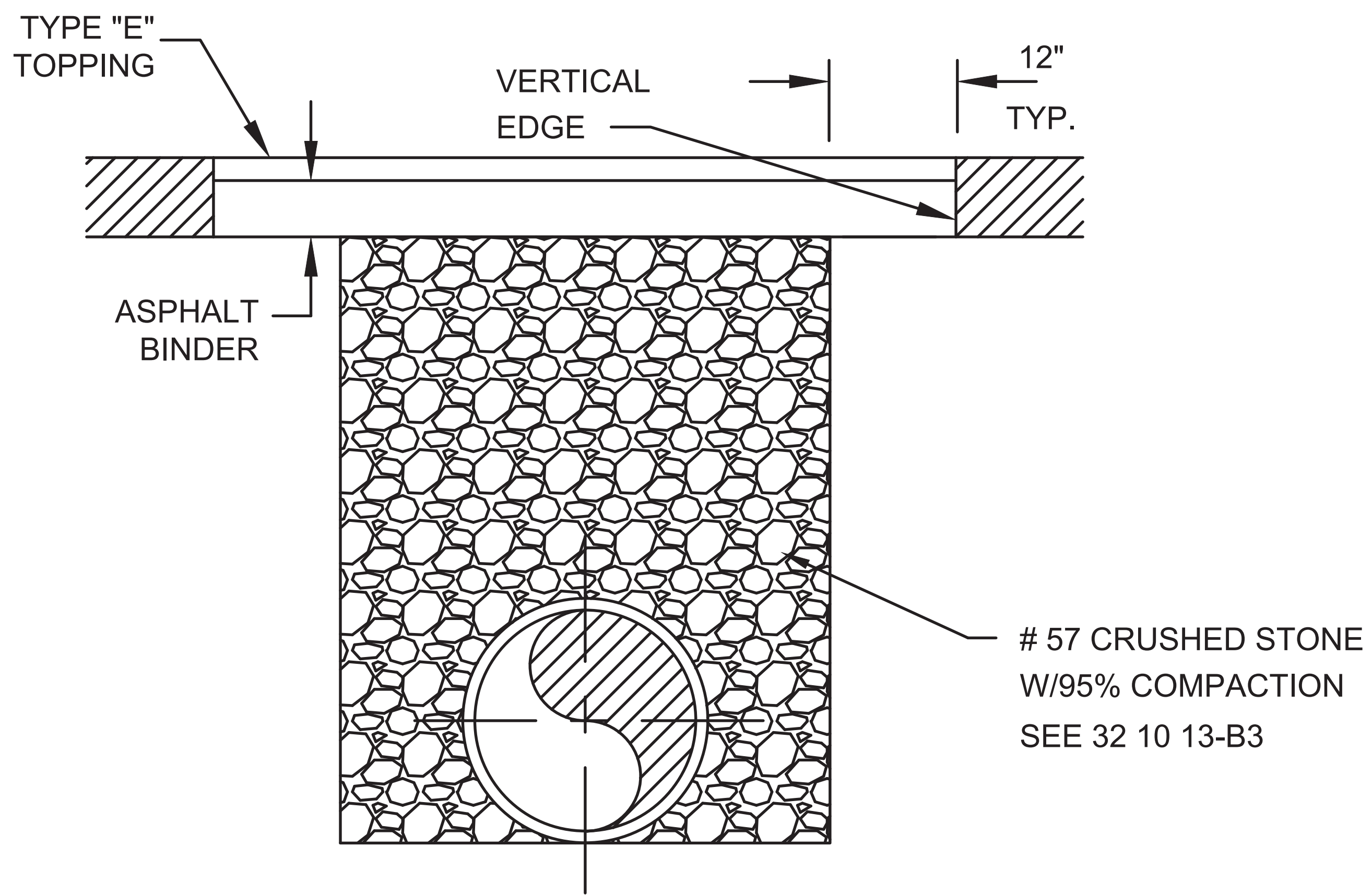

ASPHALT REPLACEMENT DETAIL

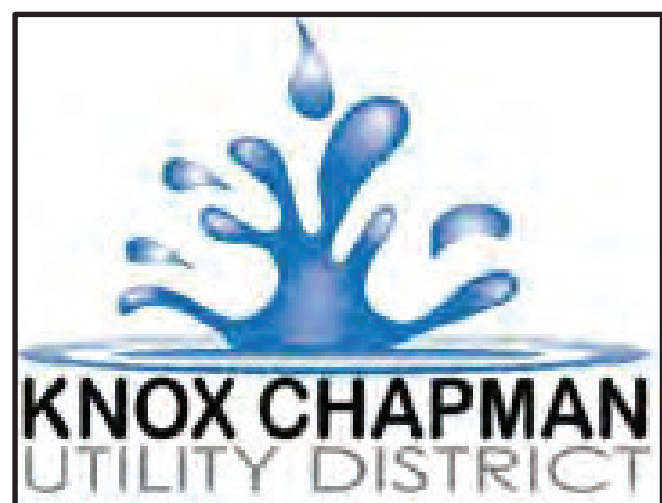

KNOX CHAPMAN UTILITY DISTRICT
WATER & SEWER

STANDARD DETAILS
WATER

DATE: JULY 2022

SCALE: N.T.S.

STD-G-04

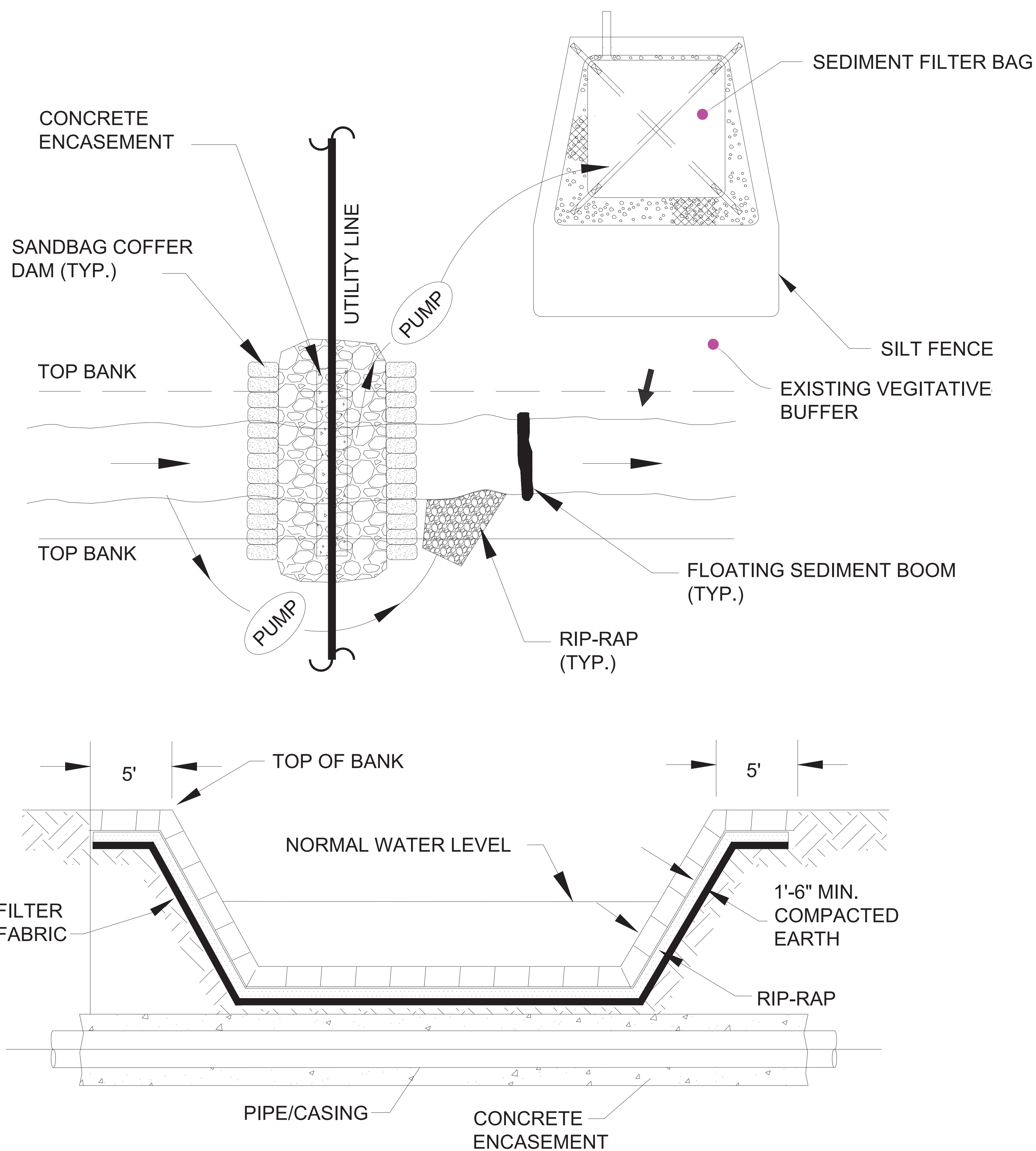

NOTES:

1. CONSTRUCT DEWATERING STRUCTURE AND LINE WITH GEOTEXTILE MATTING, MINIMUM DEPTH=2'.
2. PLACE SANDBAGS IN STREAM ABOVE AND BELOW UTILITY CROSSING.
3. DIVERT STREAM AROUND WORK AREA WITH A PUMP.
4. DEWATER WORK AREA, PUMP TO DEWATERING STRUCTURE.
5. PERMANENTLY STABILIZE CROSSING AREA AND REMOVE SANDBAGS.
6. STABILIZE ALL STREAM BANKS DISTURBED DURING CONSTRUCTION.
7. INSTALL CONCRETE ENCASEMENT A MINIMUM SPAN OF 5 FEET FROM THE TOP OF BANK ON BOTH SIDES OF THE CREEK.

STREAM CROSSING DETAIL

NTS

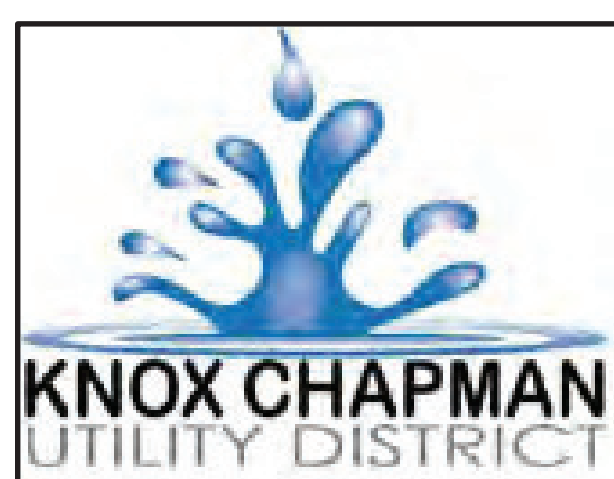

KNOX CHAPMAN UTILITY DISTRICT
WATER & SEWER

STANDARD DETAILS
SEWER

DATE: JULY 2022

SCALE: N.T.S.

STD-G-05

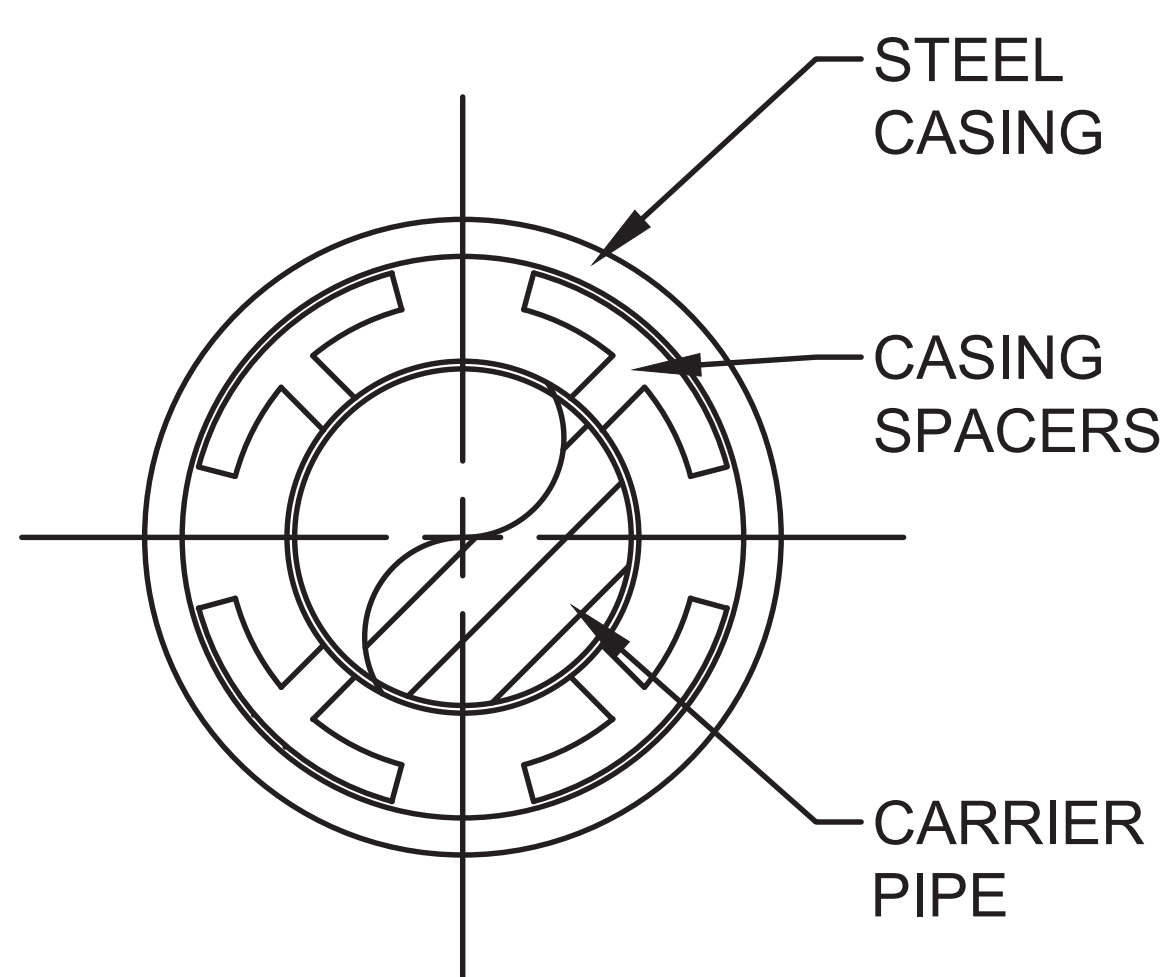
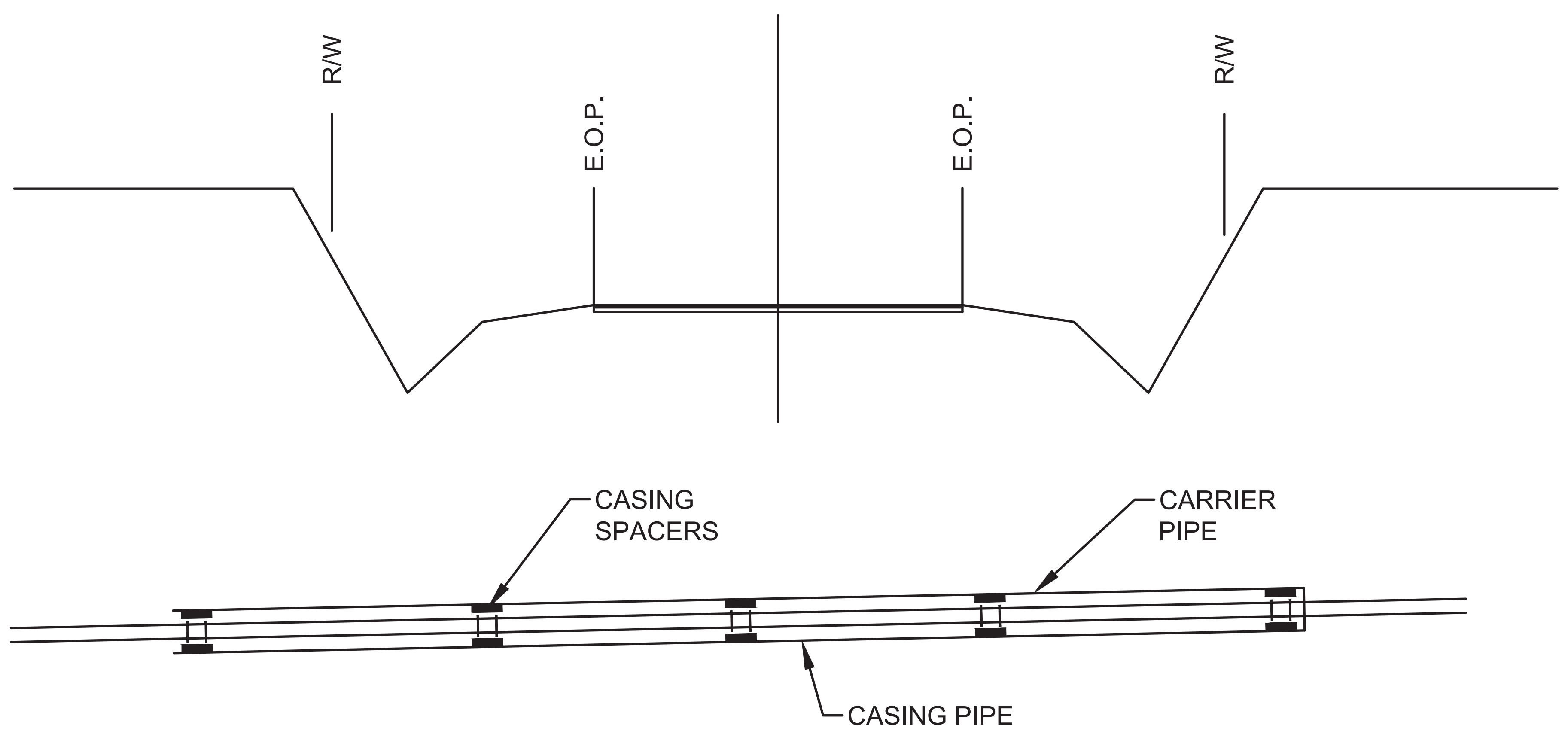

SECTION

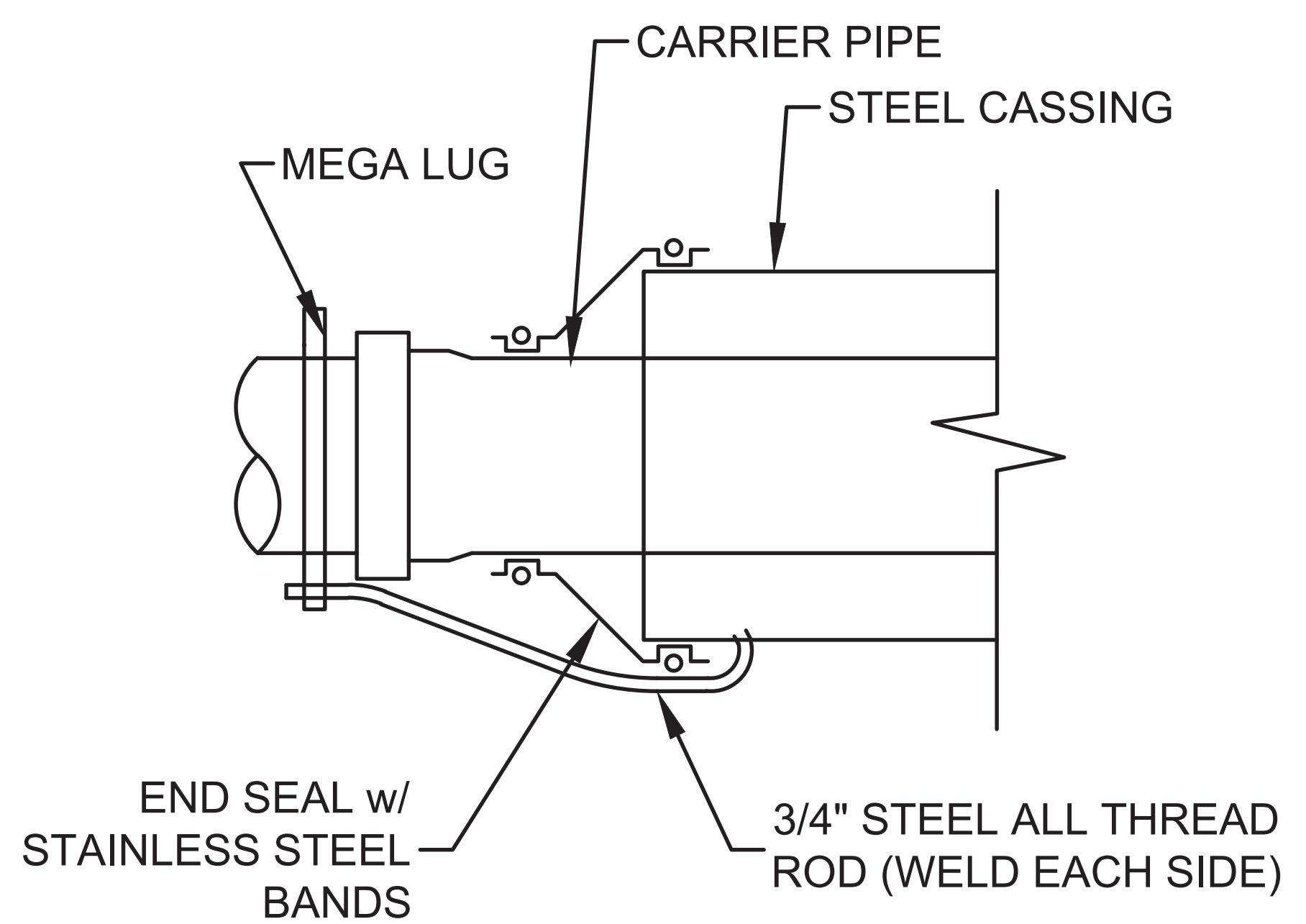

TYPICAL END SEAL

NOTES:

1. CASING SPACERS TO BE PLACED AT A MINIMUM AT SPIGOT AND MID POINT OF STICK OF PIPE (MAX EVERY 10- FEET).
2. SPACERS SHALL HAVE NONMETALLIC CONTACT SURFACES WITH CASING PIPE.
3. CASING PIPE SHALL BE WELDED STEEL.
4. CASING PIPE SHALL EXTEND BEYOND R.O.W. ON EACH SIDE OR AT A MINIMUM 10- FEET BEYOND ROAD SIDE DITCH, UNLESS NOTED OTHERWISE ON PLANS.
5. CASING PIPE SHALL HAVE A MINIMUM CLEARANCE OF 5- FEET BELOW ROAD SIDE DITCH OR LOWEST PAVEMENT ELEVATION.

ROAD BORE DETAIL

NTS

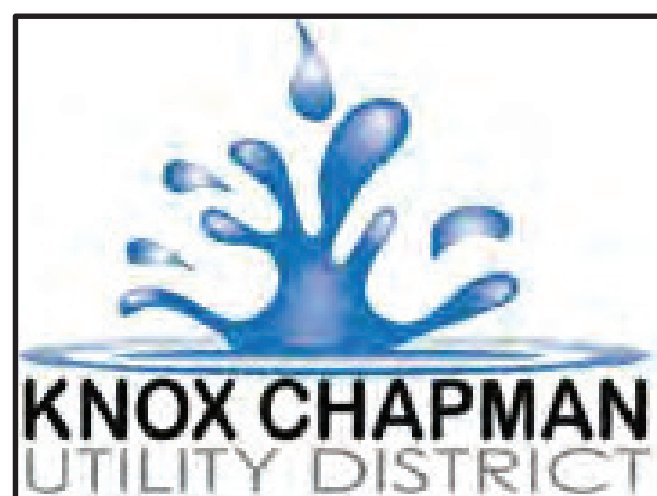

KNOX CHAPMAN UTILITY DISTRICT
WATER & SEWER

STANDARD DETAILS
WATER

DATE: JULY 2022

SCALE: N.T.S.

STD-G-06

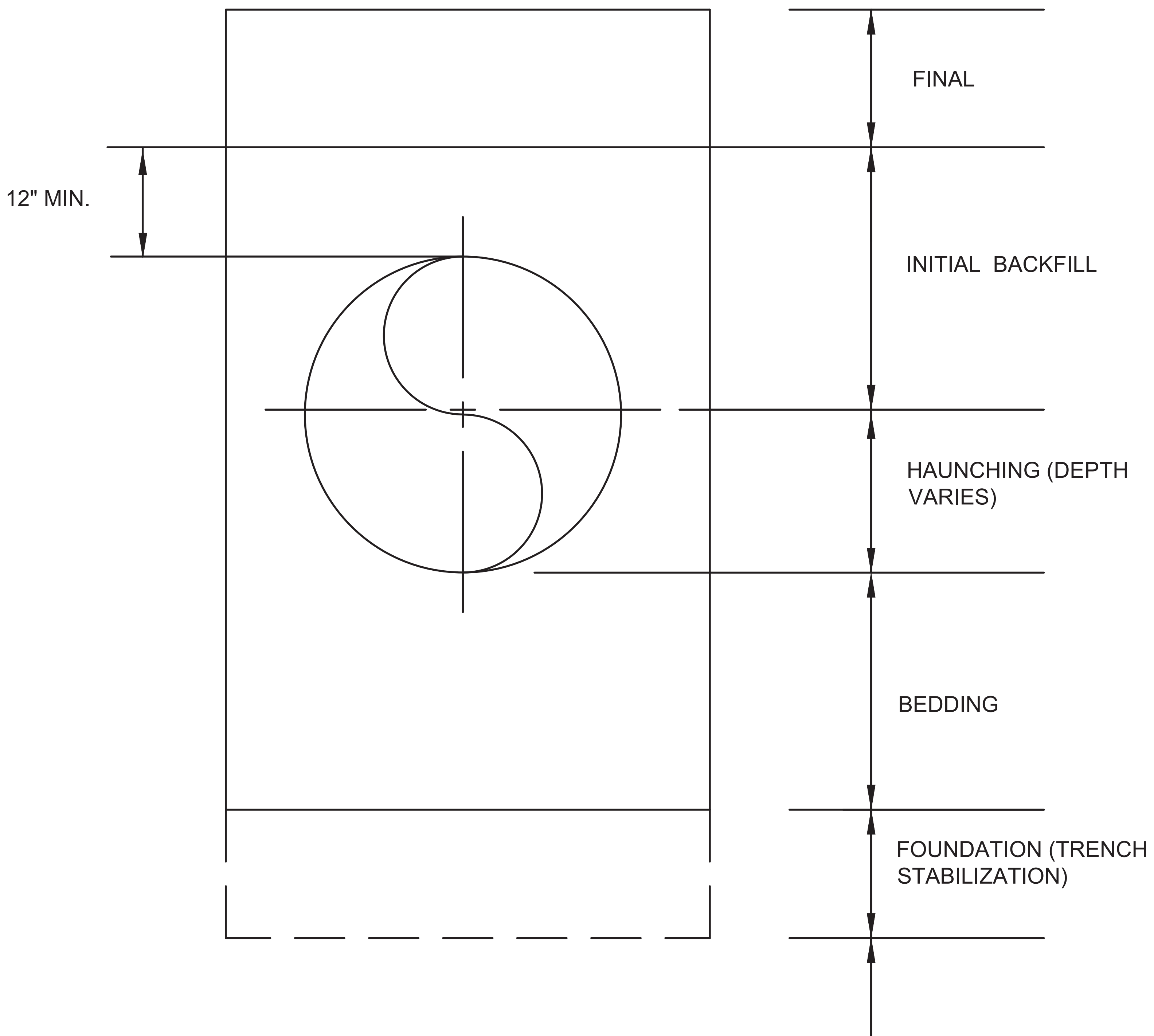

NOTE: SEE SPECIFICATIONS AND PIPE BEDDING AND HAUNCHING DETAILS FOR DIMENSIONS AND MATERIALS

TRENCH TERMINOLOGY DETAIL

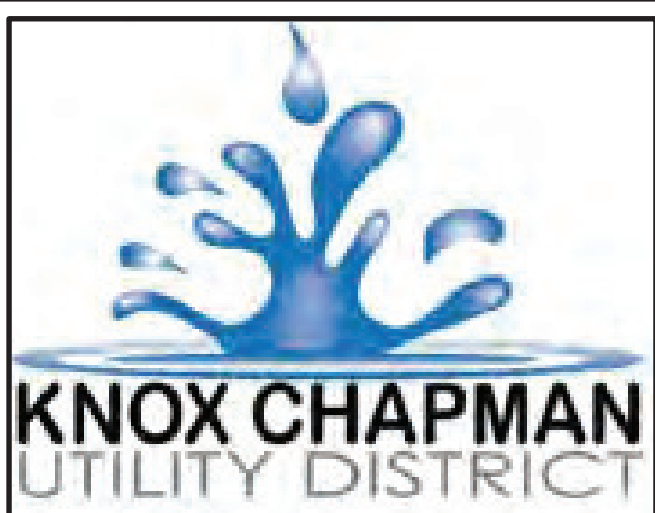

KNOX CHAPMAN UTILITY DISTRICT
WATER & SEWER

STANDARD DETAILS
WATER

DATE: JULY 2022

SCALE: N.T.S.

STD-G-07

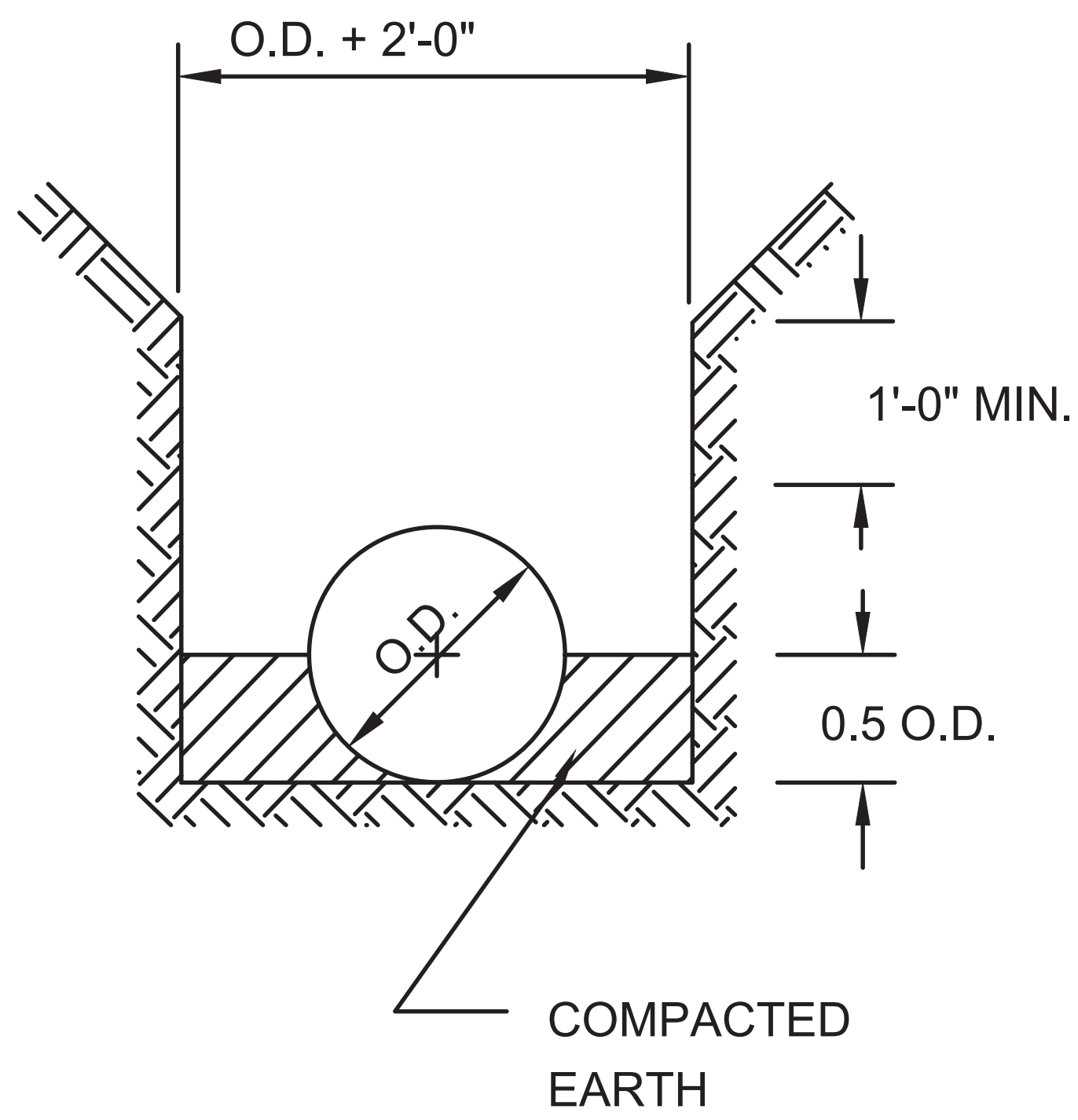

TYPE 2

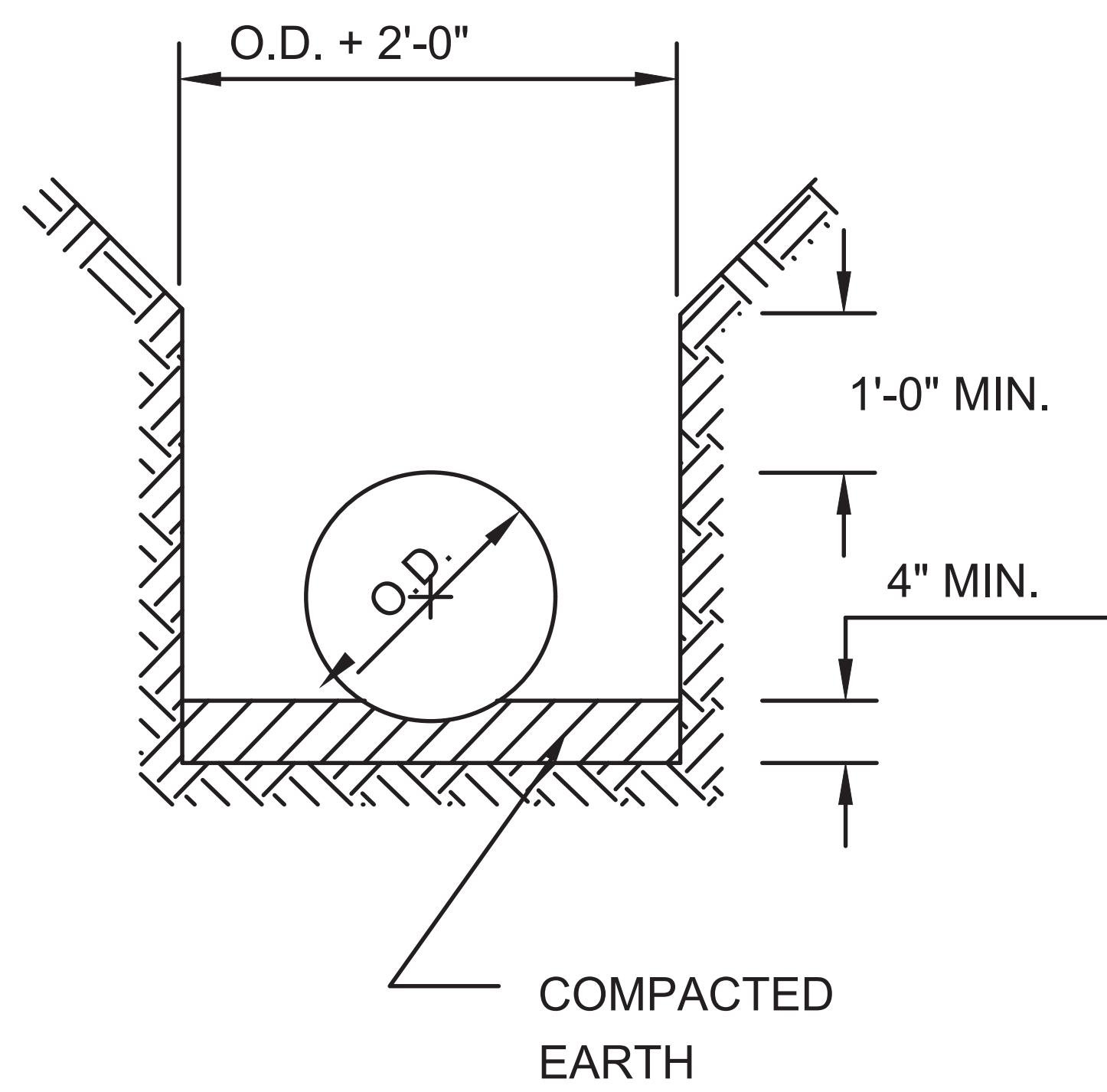

TYPE 3

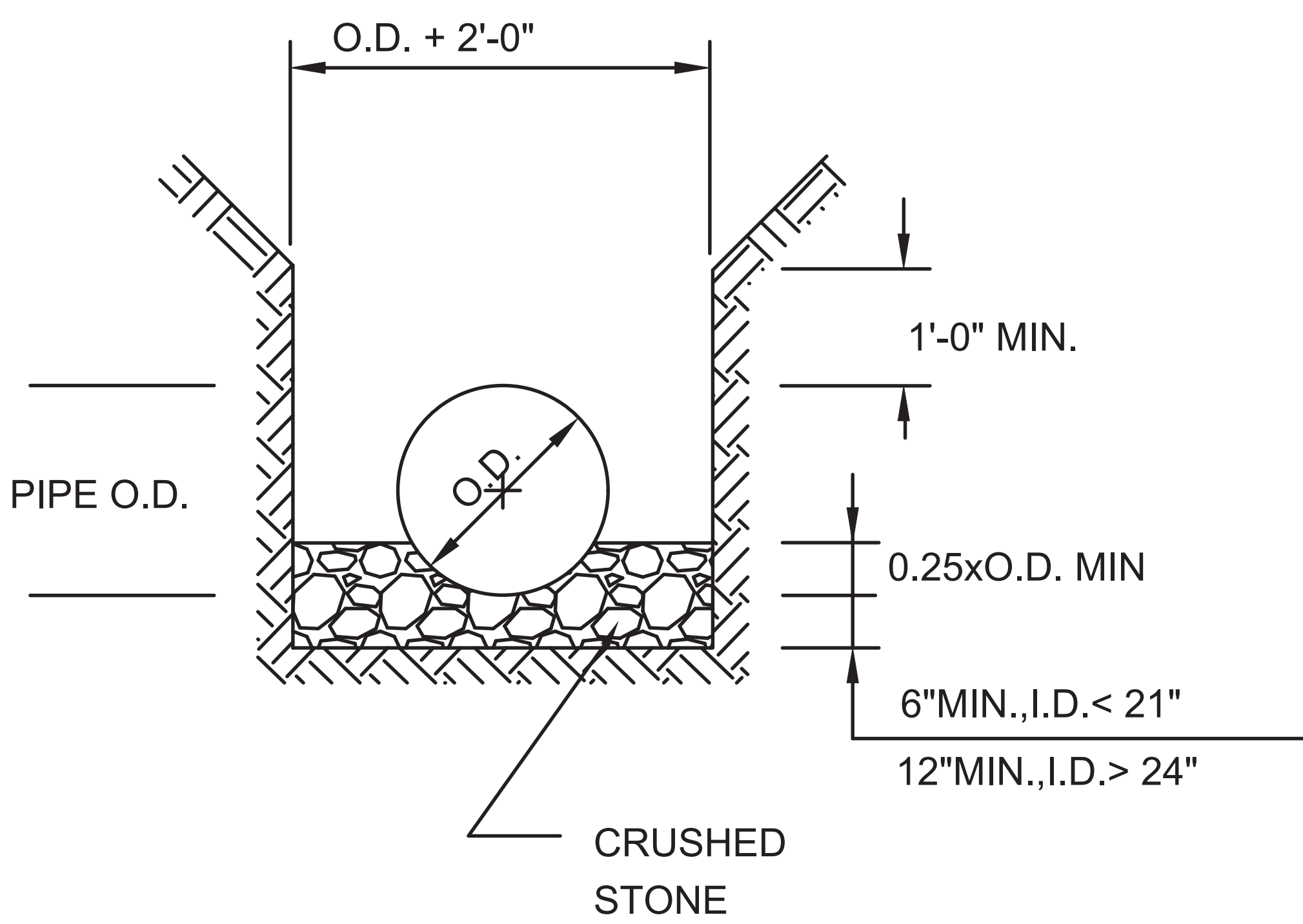

TYPE 4

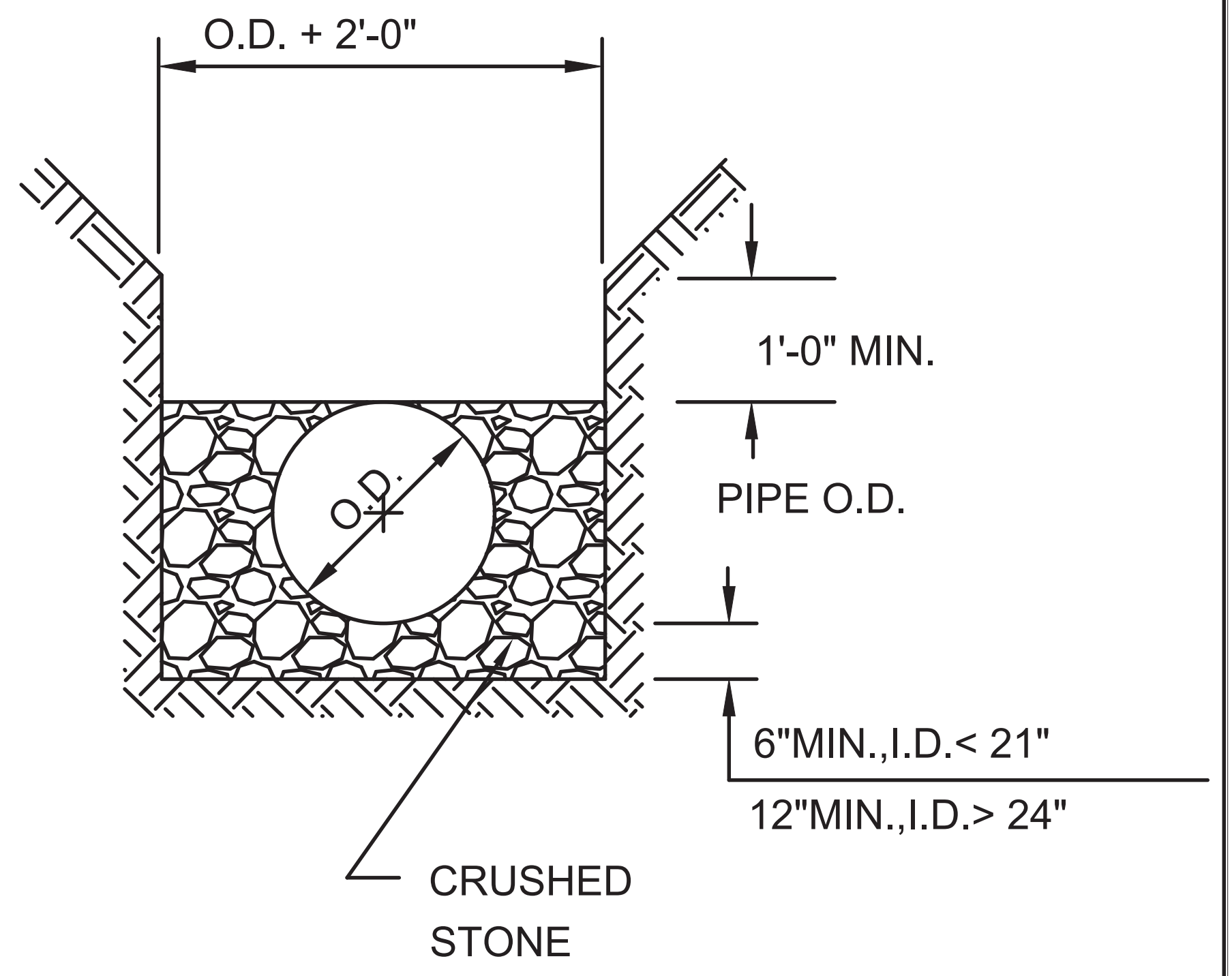

TYPE 5

**PRESSURE PIPE BEDDING AND
HAUNCING DETAILS**

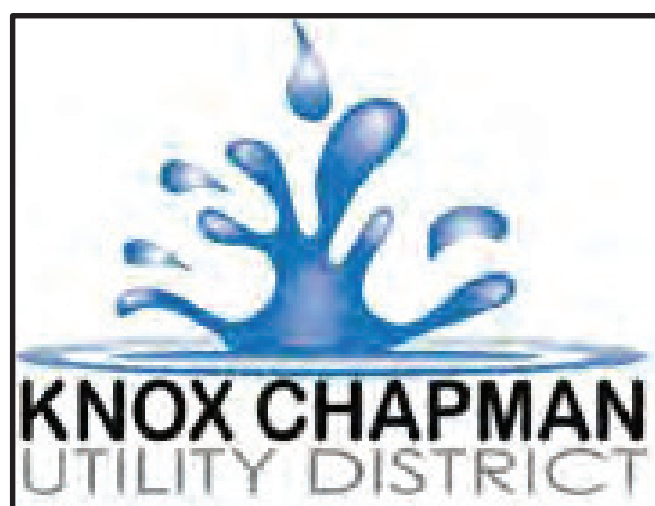

KNOX CHAPMAN UTILITY DISTRICT
WATER & SEWER

STANDARD DETAILS
WATER

DATE: JULY 2022

SCALE: N.T.S.

STD-G-08

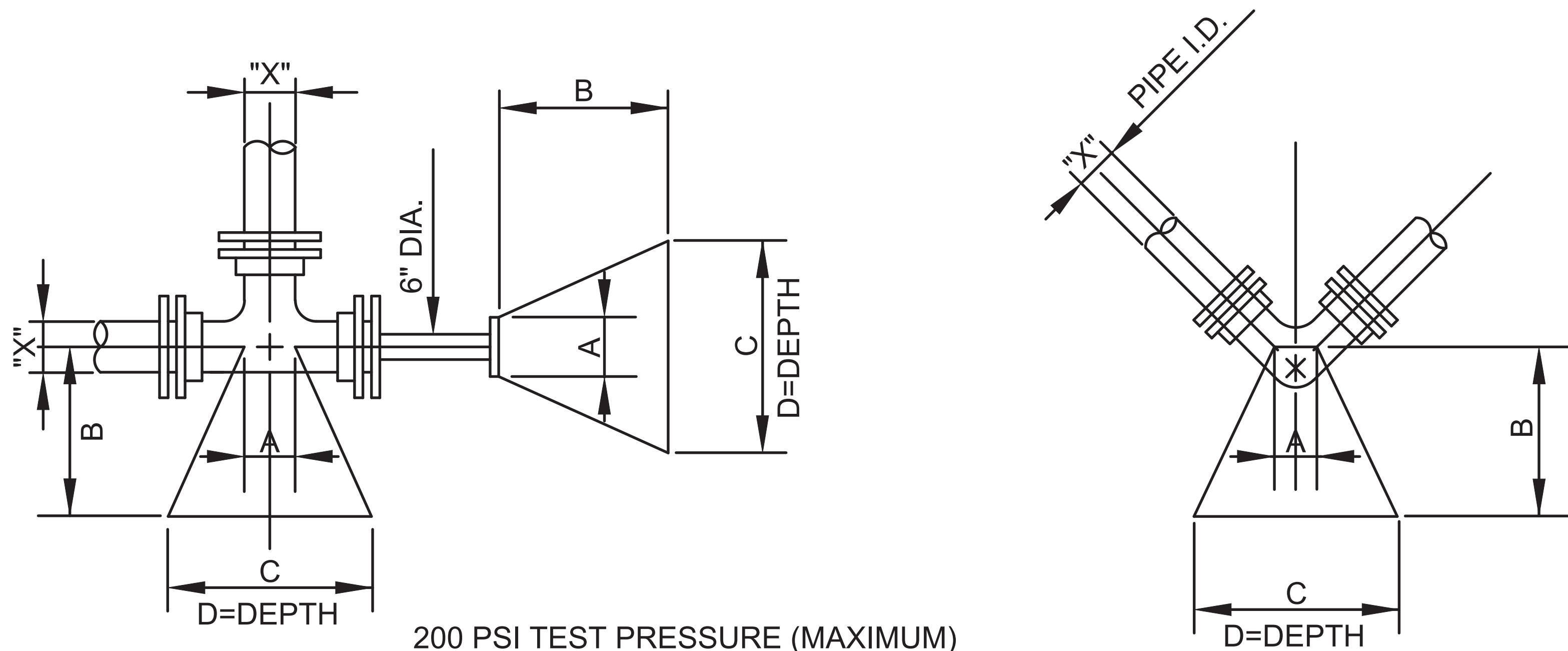

200 PSI TEST PRESSURE (MAXIMUM)
2000 PSF SOIL BEARING

BLOCKING DIMENSIONS						
DEAD END & TEES	X*	A	B	C	D	
	16"	1'-6"	3'-3"	9'-6"30"	4'-8"	
	12"	1'-0"	5'-4"	7'-2"	3'-7"	
	8"	0'-10"	3'-5"	4'-9"	2'-5"	
	6"	0'-8"	2'-6"	3'-7"	1'-9"	
BENDS	90°	16"	1'-6"	4'-0"	11'-2"	5'-7"
		12"	1'-0"	4'-4"	6'-0"	3'-0"
		8"	0'-10"	2'-9"	4'-0"	2'-0"
		6"	0'-8"	2'-0"	3'-0"	1'-6"
	45°	16"	1'-6"	2'-9"	8'-2"	4'-1"
		12"	1'-0"	2'-11"	4'-5"	2'-2"
		8"	0'-10"	1'-10"	2'-11"	1'-6"
		6"	0'-8"	1'-4"	2'-2"	1'-1"
	22 1/2°	16"	1'-6"	1'-9"	0'-7"	2'-11"
		12"	1'-0"	1'-10"	3'-2"	1'-7"
		8"	0'-10"	1'-1"	2'-1"	1'-1"
		6"	0'-8"	0'-9"	1'-7"	0'-9"
	11 1/4°	16"	1'-6"	1'-0"	4'-2"	2'-1"
		12"	1'-0"	1'-1"	2'-3"	1'-1"
		8"	0'-10"	0'-7"	1'-6"	0'-9"
		6"	0'-8"	0'-5"	1'-1"	0'-7"

X* = DIAMETER OF PIPE TO BE BLOCKED

NOTES:

1. SOIL CONDITIONS SHALL BE VERIFIED BY THE ENGINEER BEFORE THRUST BLOCK DESIGN IS IMPLEMENTED.
2. POUR BLOCKING AGAINST UNDISTURBED EARTH WHEN OVEREXCAVATION OCCURS.

DESIGN DATA:

1. DIMENSION OF THRUST BLOCK IN FEET BASED ON 2000 POUNDS PER SQUARE FOOT SOIL BEARING PRESSURE. ACTUAL INSIDE DIA. OF D.I.P., CLASS 51,250 P.S.I. TEST PRESSURE.
2. CONCRETE SHALL BE CLASS A, 3000 P.S.I.
3. UNDER ADVERSE CONSTRUCTION CONDITIONS, CONCRETE SHALL BE "HIGH EARLY" TYPE.

TYPICAL BLOCKING

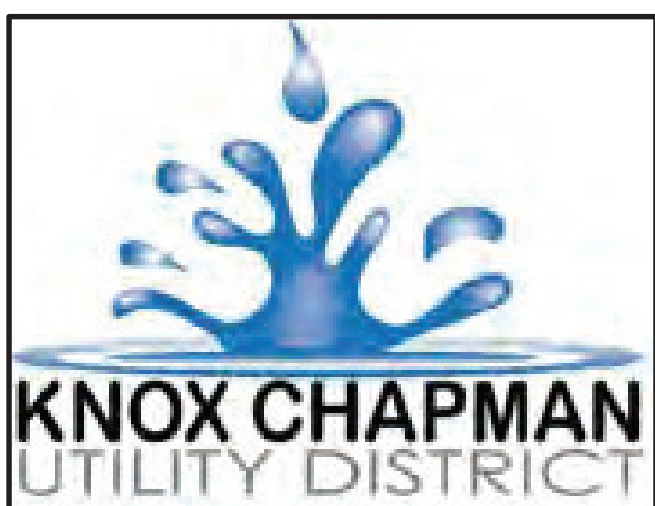

KNOX CHAPMAN UTILITY DISTRICT
WATER & SEWER

STANDARD DETAILS
WATER

DATE: JULY 2022

SCALE: N.T.S.

STD-W-01

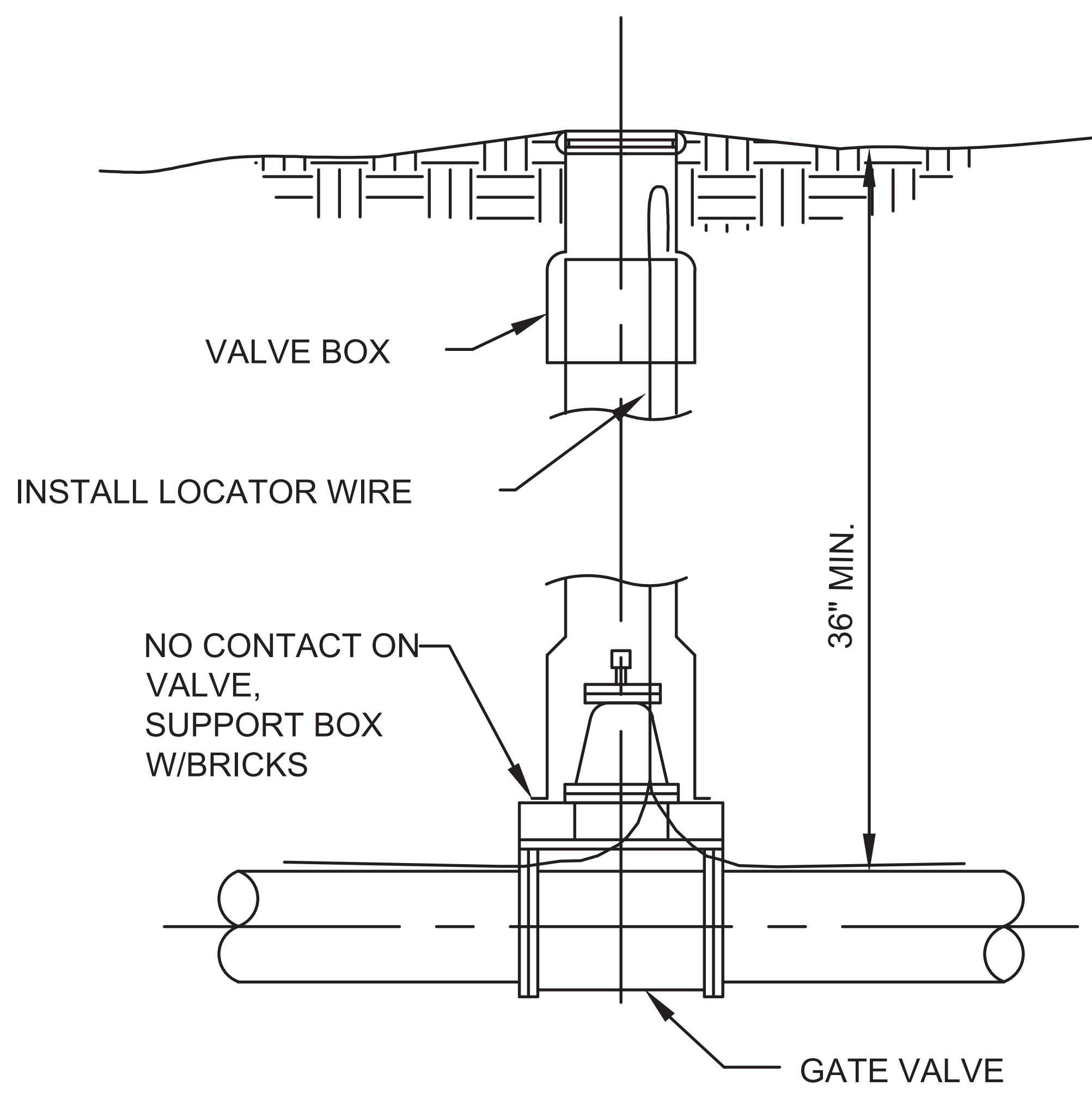

GATE VALVE
INSTALLATION DETAIL

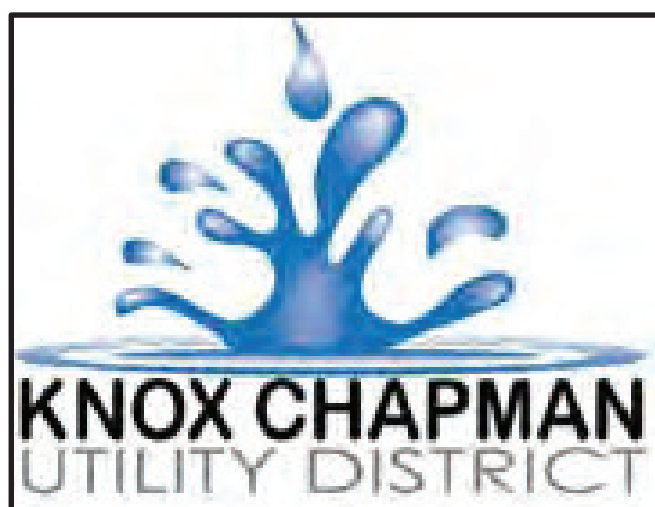

KNOX CHAPMAN UTILITY DISTRICT
WATER & SEWER

STANDARD DETAILS
WATER

DATE: JULY 2022

SCALE: N.T.S.

STD-W-02

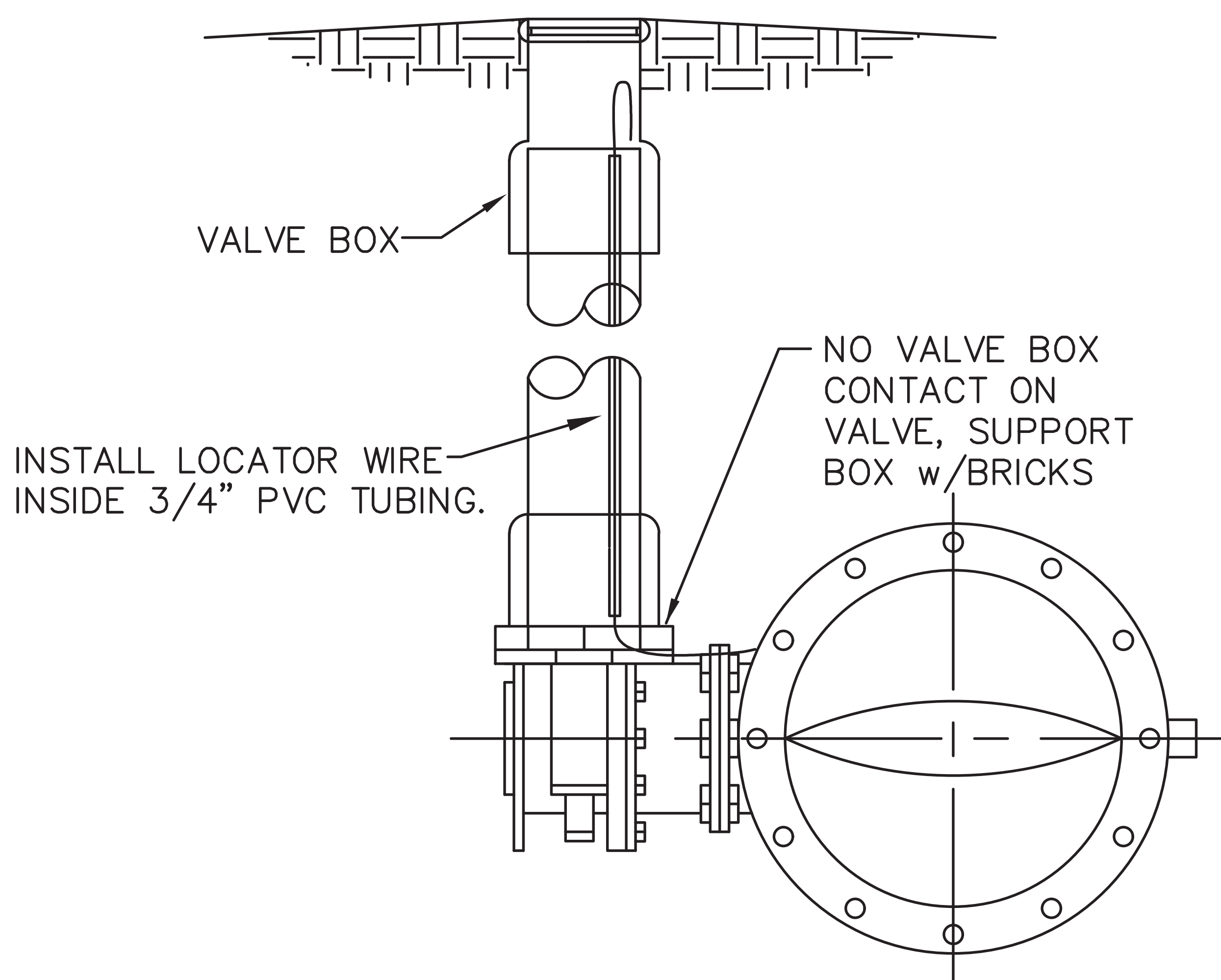

**BUTTERFLY VALVE
INSTALLATION DETAIL**

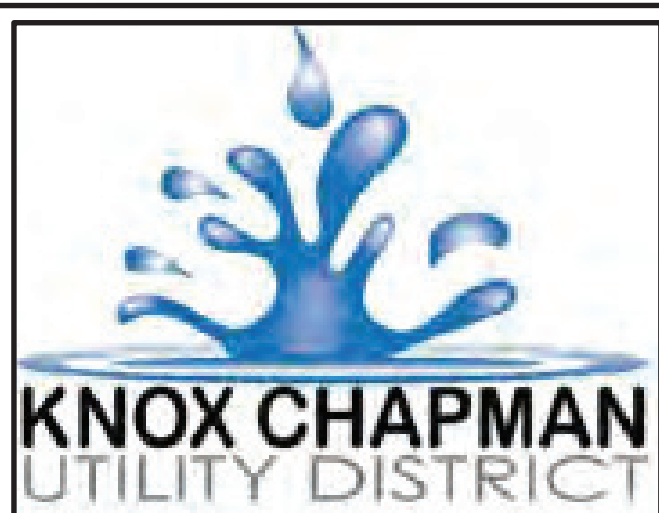

KNOX CHAPMAN UTILITY DISTRICT
WATER & SEWER

STANDARD DETAILS
WATER

DATE: JULY 2022

SCALE: N.T.S.

STD-W-03

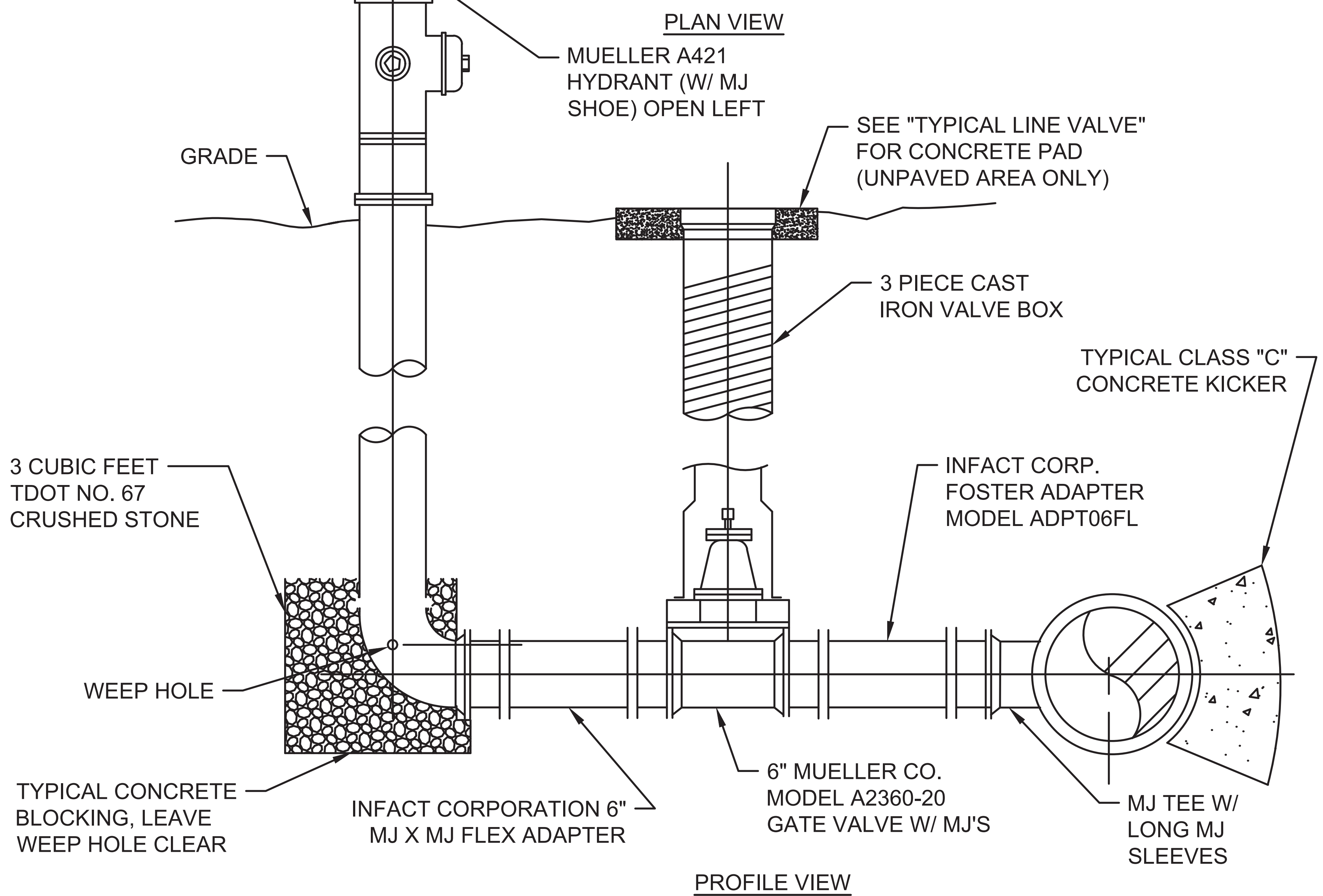
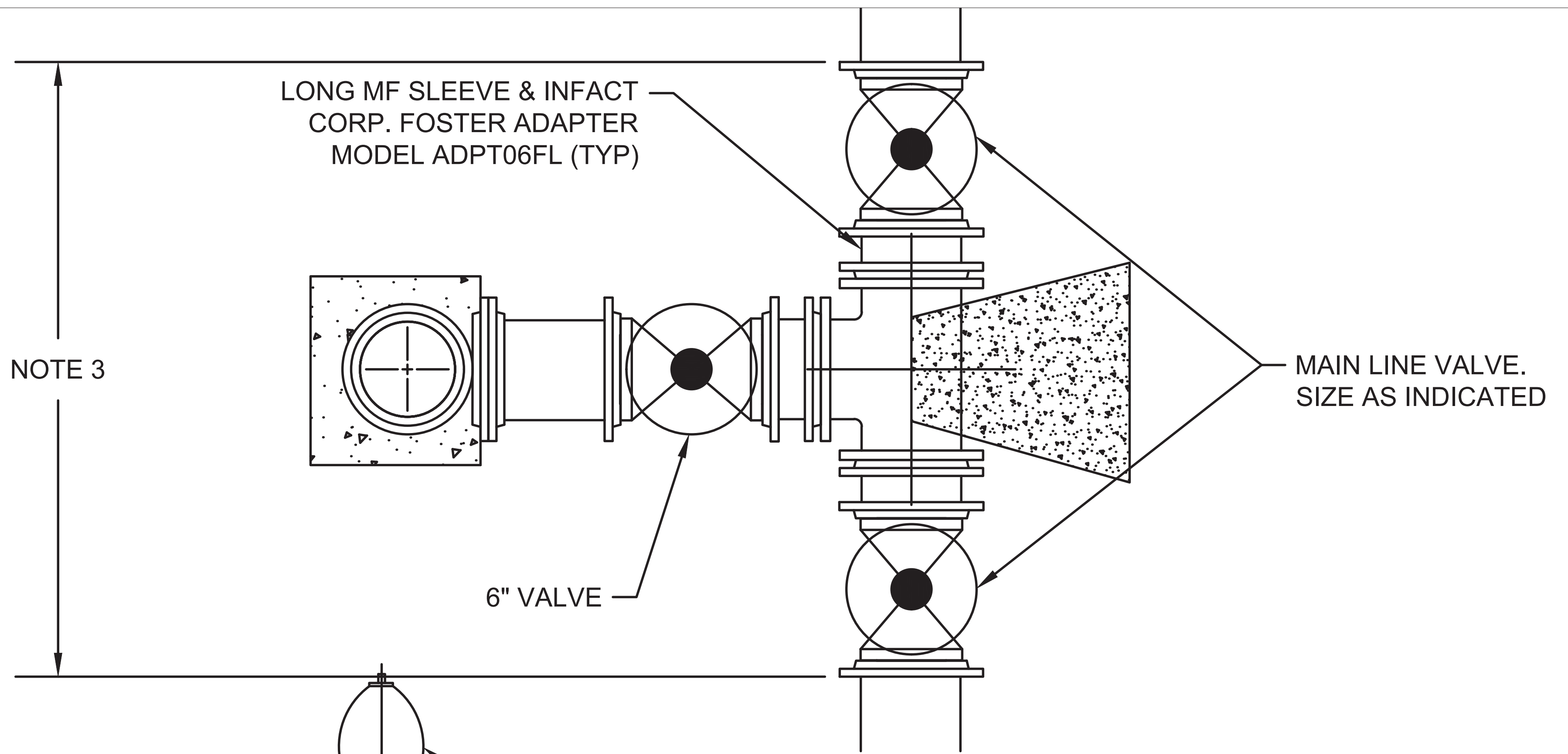

NOTE:

1. USE TAPPING SLEEVE AS SPECIFIED FOR FIRE HYDRANT INSTALLATION ON EXISTING WATER LINES.
2. DIP WITH RETAINER GLANDS MAY BE USED WHEN THE DISTANCE BETWEEN THE VALVE AND HYDRANT EXCEEDS 3-FEET.
3. LIMITS OF LUMP SUM FIRE HYDRANT ASSEMBLY INCLUDES TWO (2) MAIN LINE VALVES, 6" VALVE, MJ TEE, FLEX ADAPTER, FIRE HYDRANT, ANCHORAGE, STONE WITHIN THE LIMITS SHOWN.

FIRE HYDRANT ASSEMBLY
NTS

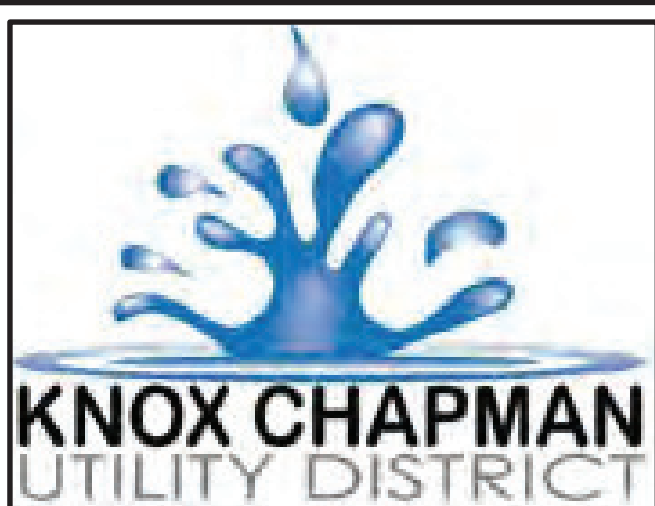

KNOX CHAPMAN UTILITY DISTRICT
WATER & SEWER

STANDARD DETAILS
WATER

DATE: JULY 2022

SCALE: N.T.S.

STD-W-04

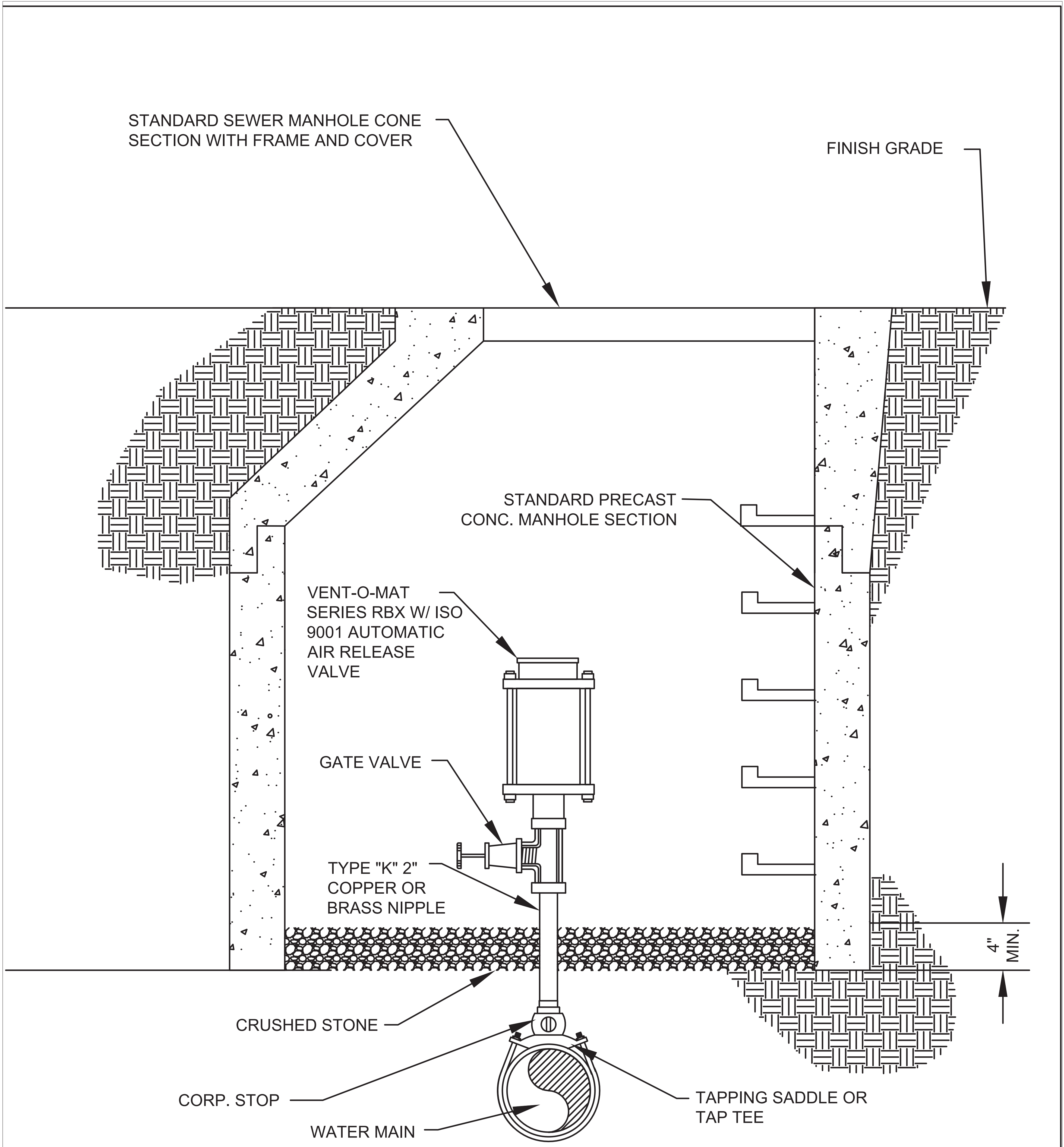

**TYPICAL AUTOMATIC AIR
RELEASE VALVE ASSEMBLY**

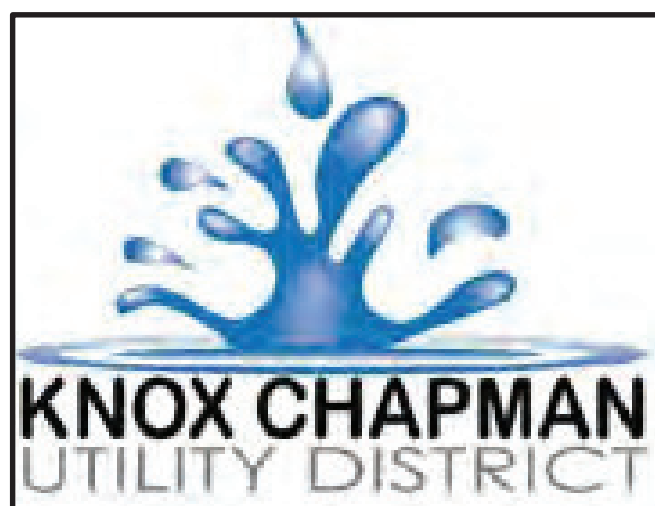

KNOX CHAPMAN UTILITY DISTRICT
WATER & SEWER

STANDARD DETAILS
WATER

DATE: JULY 2022

SCALE: N.T.S.

STD-W-05

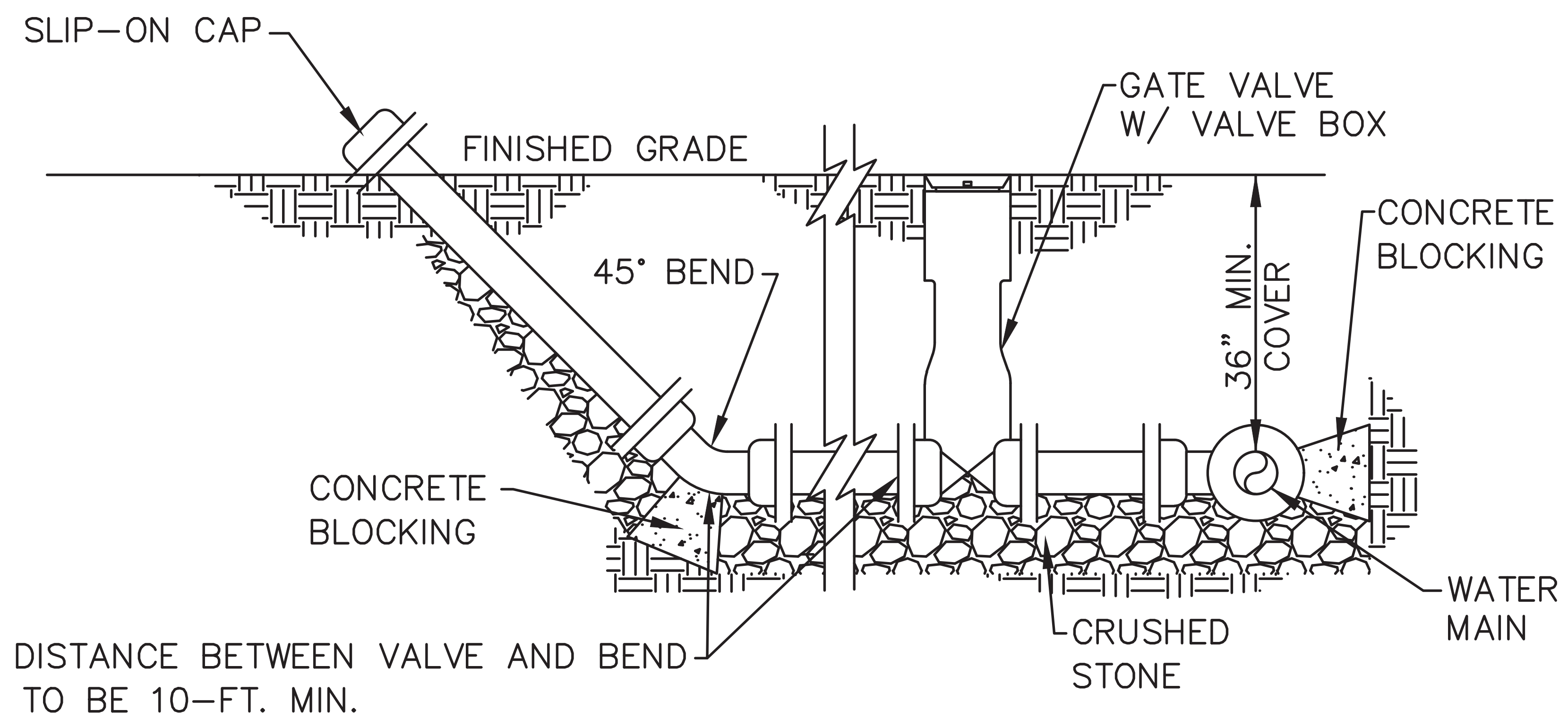

MANUAL IN-LINE BLOW-OFF DETAIL

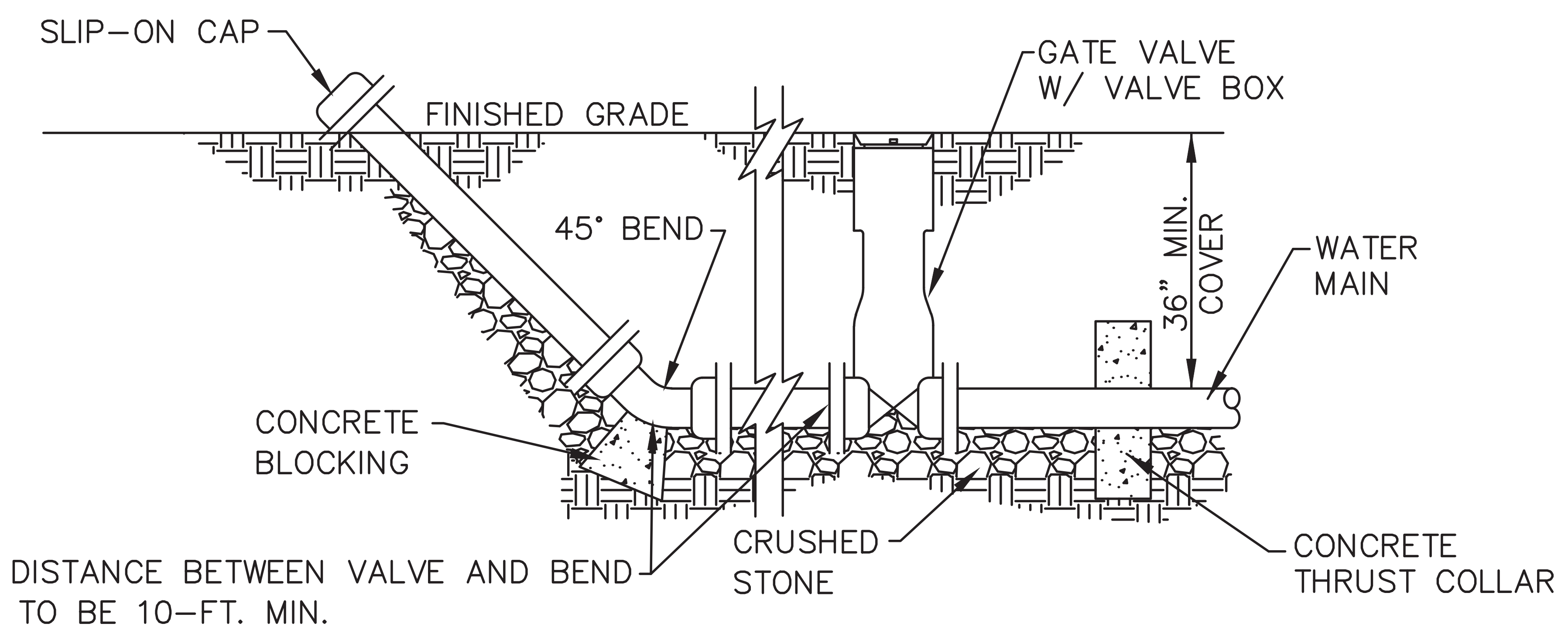

MANUAL END OF LINE BLOW-OFF DETAIL

NOTE:

1. CONCRETE BLOCKING AT THRUST BLOCK SHALL BE A MINIMUM OF 1'-6" THICK AND BE OUT A MINIMUM OF 1'-0" INTO UNDISTURBED SOIL ON EACH SIDE AND BELOW TRENCH

WATER MAIN BLOW-OFF DETAIL
LARGE DIA. MAINS

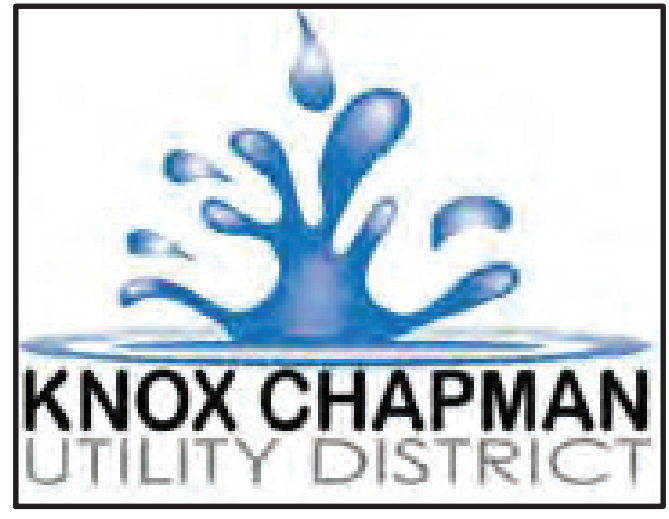

KNOX CHAPMAN UTILITY DISTRICT
WATER & SEWER

STANDARD DETAILS
WATER

DATE: JULY 2022
SCALE: N.T.S.

STD-W-06

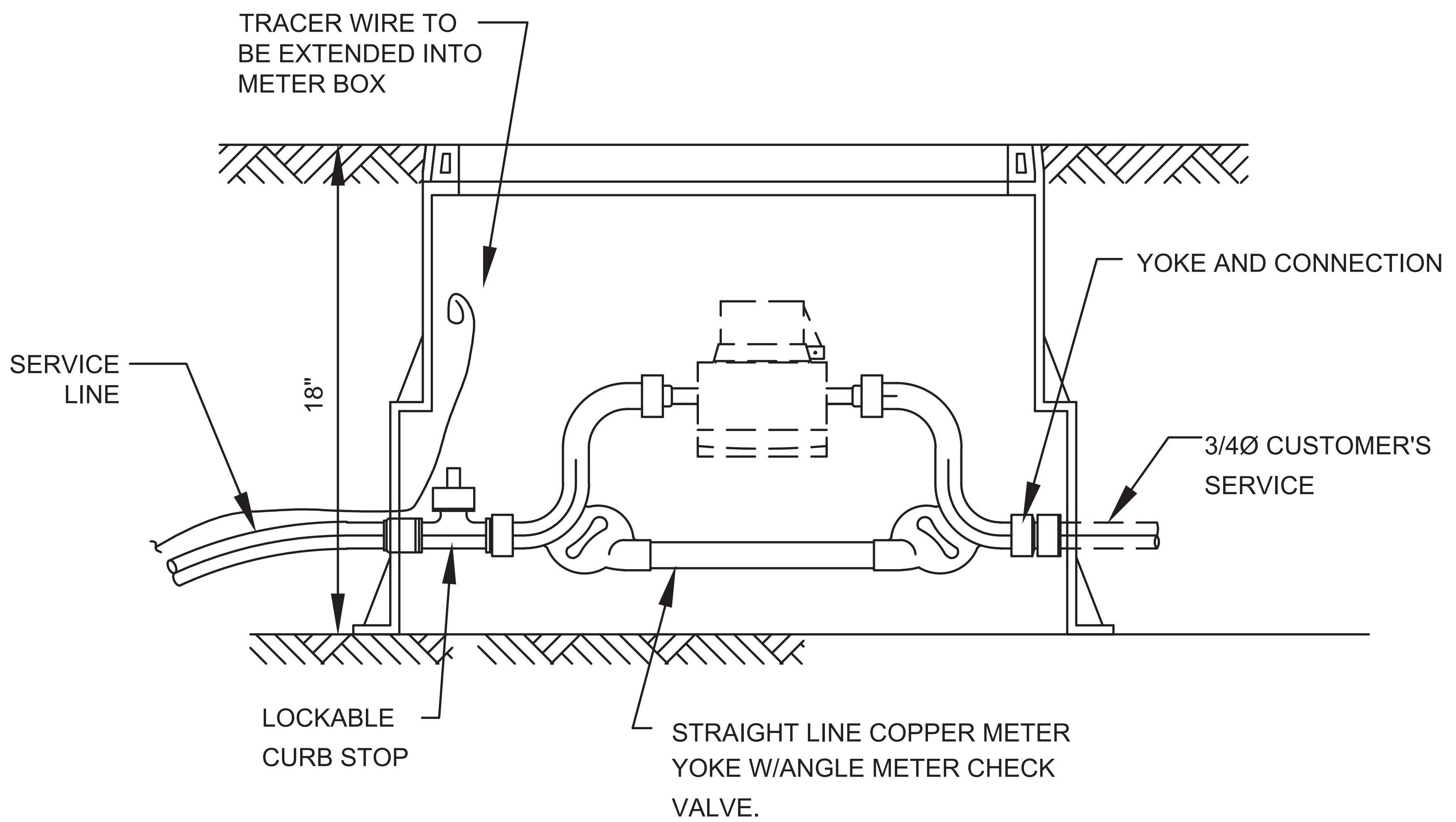

ELEVATION

TRACER WIRE TO RUN WITH SERVICE LINE AND SPLICED TO MAIN LINE TRACER WIRE WITH BRASS CURNEY.

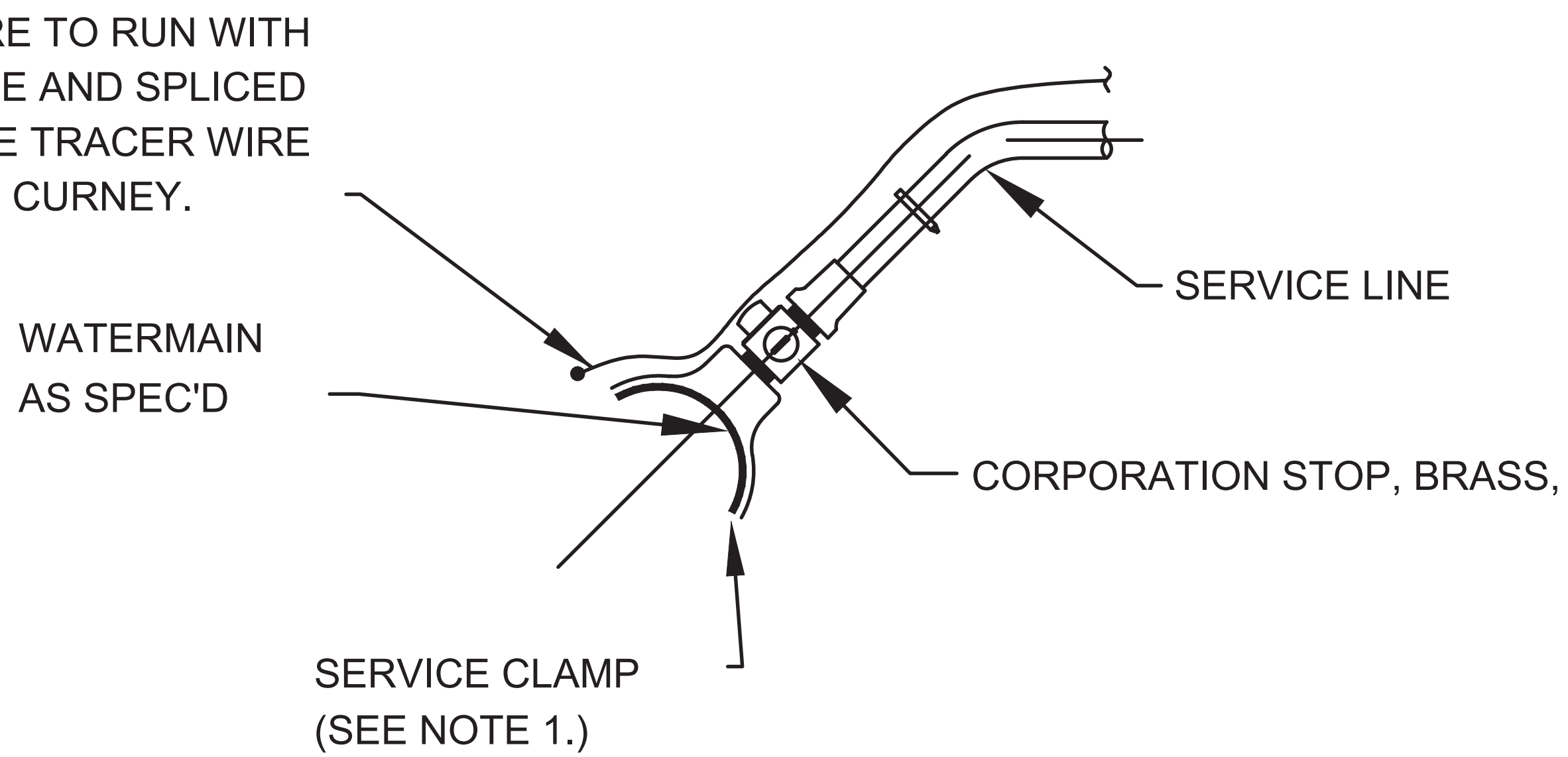

ELEVATION

NOTES:

1. SERVICE CLAMP REQUIRED ON ALL CONNECTIONS.
2. USE 1" SERVICE LINE FOR SINGLE SERVICE CONNECTION AND 1" SERVICE LINE FOR DOUBLE SERVICE CONNECTION.

WATER SERVICE & METER CONNECTION DETAILS

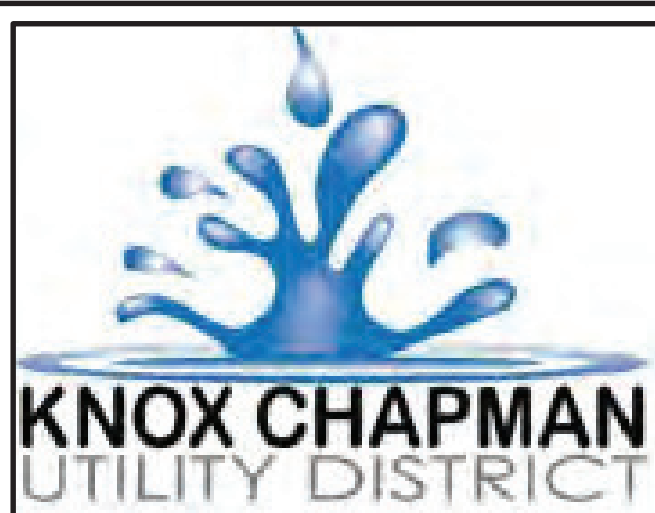

KNOX CHAPMAN UTILITY DISTRICT
WATER & SEWER

STANDARD DETAILS
WATER

DATE: JULY 2022

SCALE: N.T.S.

STD-W-07

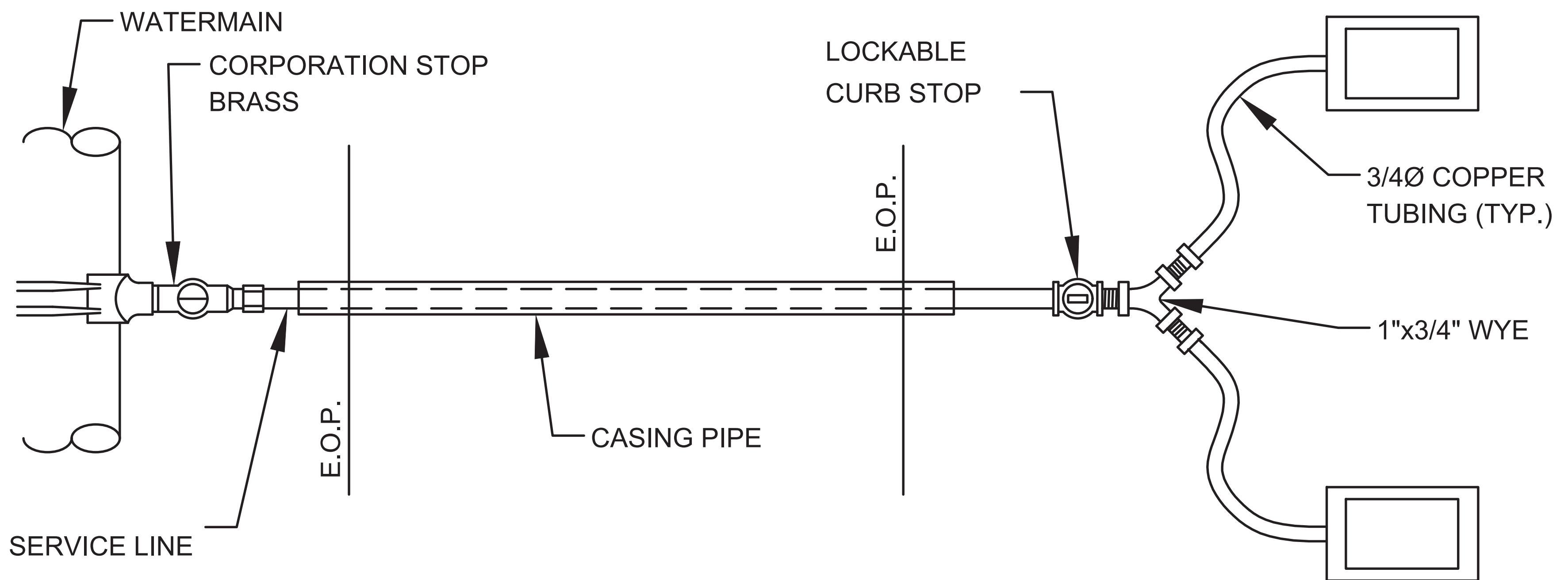
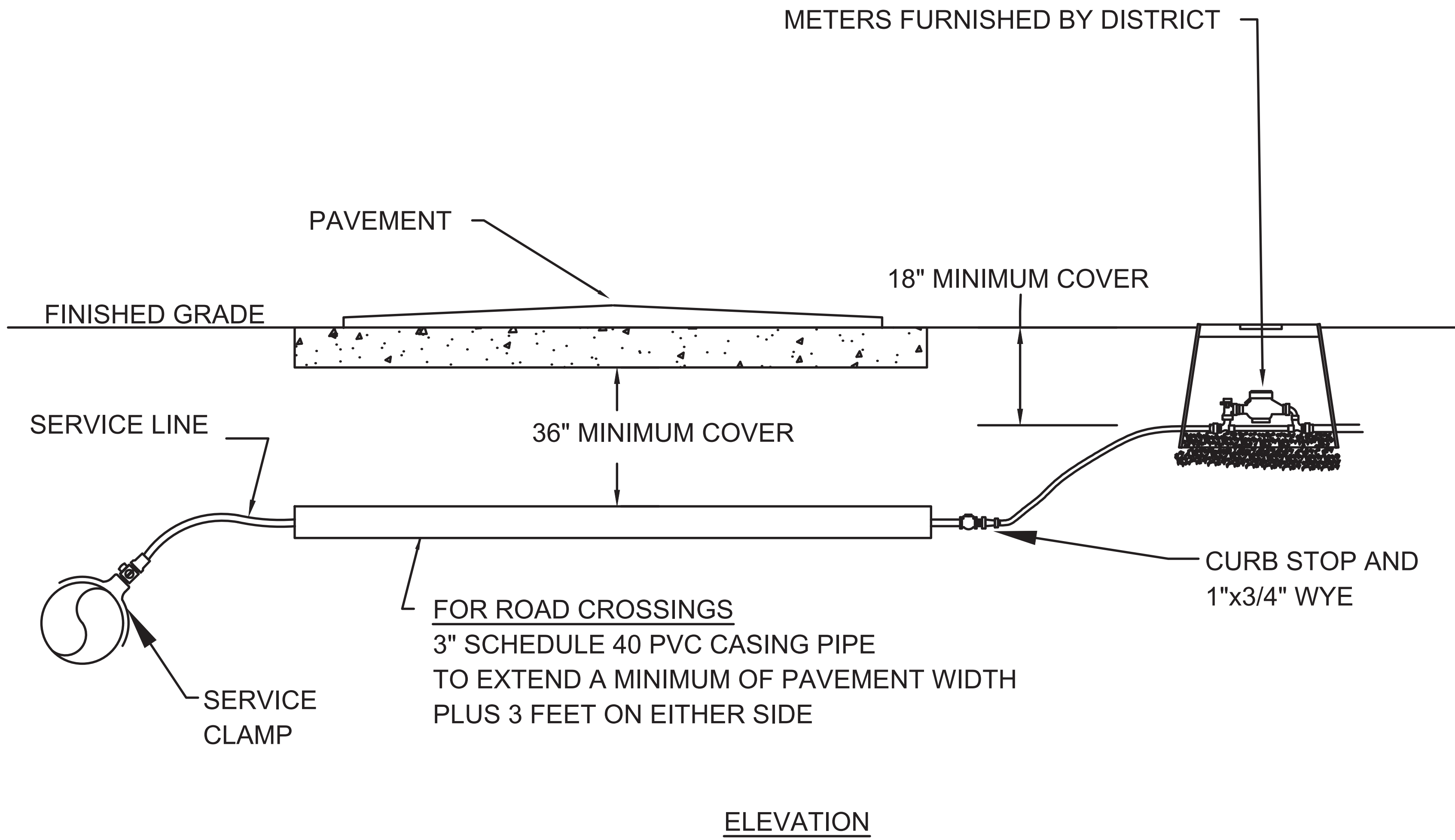

NOTES:

1. SERVICE CLAMP REQUIRED ON ALL CONNECTIONS.
2. USE 1" SERVICE LINE FOR SINGLE SERVICE CONNECTION AND 1" SERVICE LINE FOR DOUBLE SERVICE CONNECTION.

DOUBLE TAP ASSEMBLIES

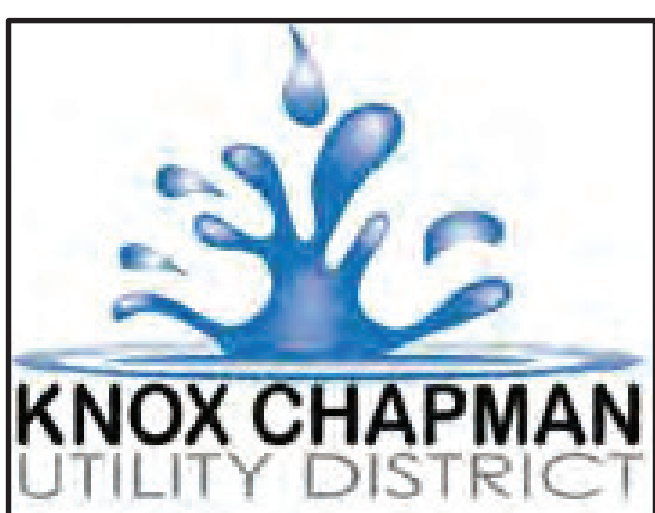

KNOX CHAPMAN UTILITY DISTRICT
WATER & SEWER

STANDARD DETAILS
WATER

DATE: JULY 2022

SCALE: N.T.S.

STD-W-08

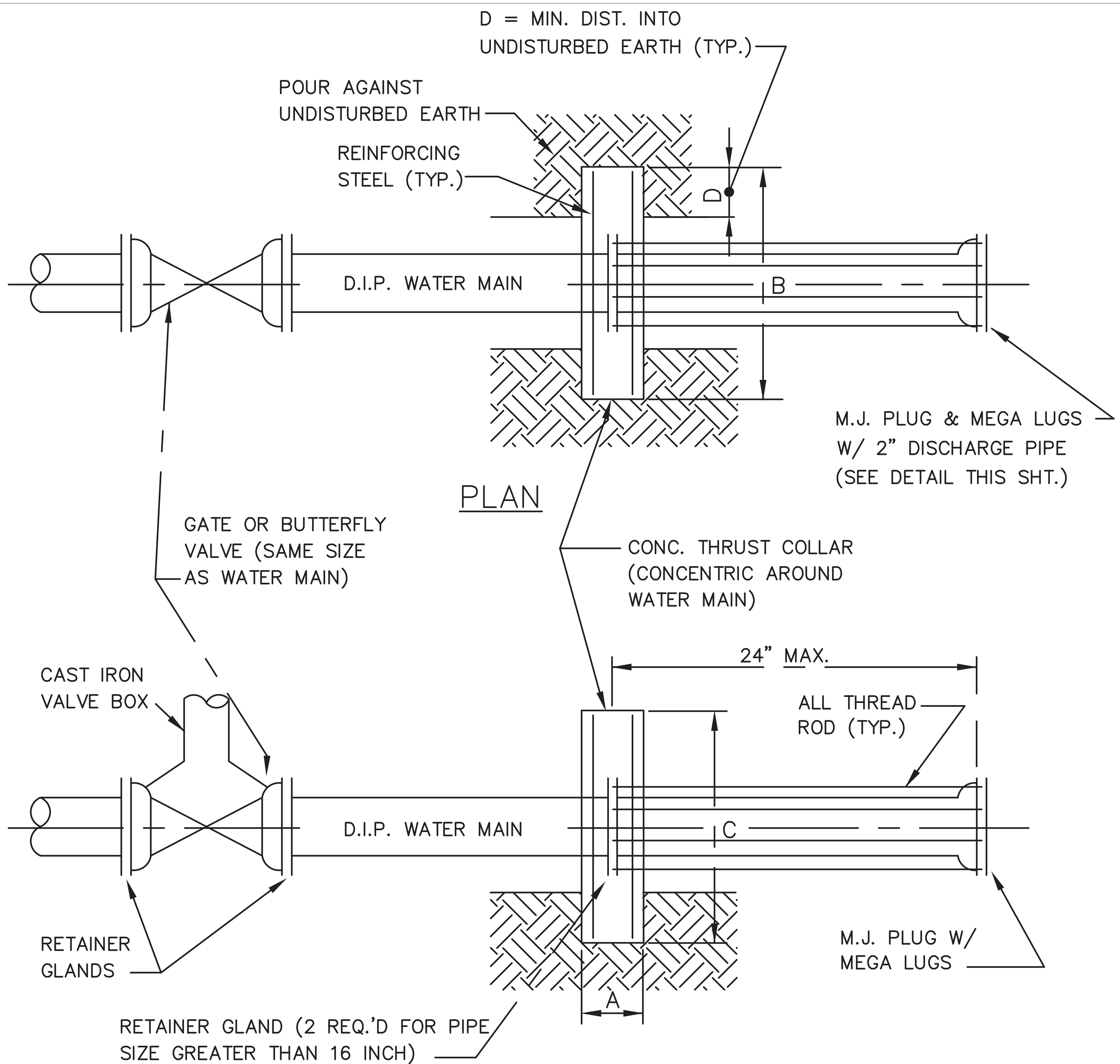

SECTION

TEST PRESSURE: 250 P.S.I.
 SOIL BEARING PRESSURE: 3000 P.S.F.

MAIN DIA	CONCRETE COLLAR DIM.				STEEL REINFORCING
	A	B	C	D	
24"	1'-9"	9'-0"	9'-0"	2'-6"	#9 @ 8" O.C. E.W.E.F.
20"	1'-6"	7'-8"	7'-8"	2'-0"	#9 @ 12" O.C. E.W.E.F.
16"	1'-3"	6'-6"	6'-6"	1'-6"	#8 @ 12" O.C. E.W.E.F.
12"	1'-2"	5'-3"	5'-3"	1'-0"	#7 @ 12" O.C. E.W.E.F.
6" or 8"	1'-0"	4'-0"	4'-0"	0'-8"	#6 @ 12" O.C. E.W.E.F.

WATER MAIN TERMINATION DETAIL

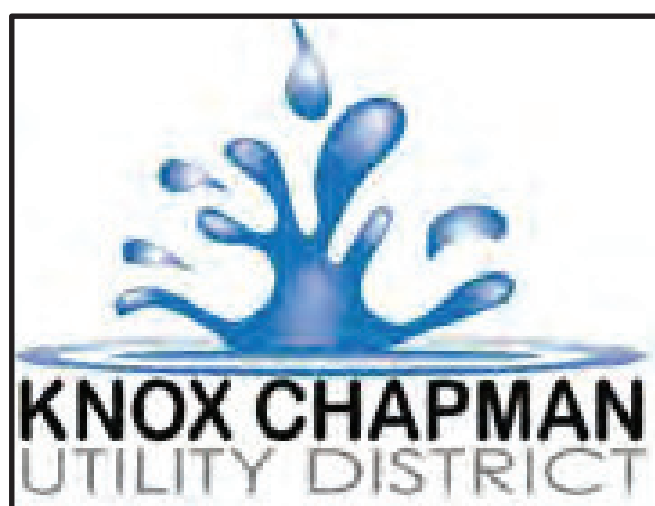

KNOX CHAPMAN UTILITY DISTRICT
 WATER & SEWER

STANDARD DETAILS
 WATER

DATE: JULY 2022
 SCALE: N.T.S.

STD-W-09